

MOTOROLA POWERPC 603E™ MICROPROCESSOR

The Motorola PowerPC 603e microprocessor is a low-power implementation of the PowerPC Reduced Instruction Set Computer (RISC) architecture. The PowerPC 603e microprocessor offers workstation-level performance packed into a low-power, low-cost design ideal for desktop computers, notebooks and battery-powered systems, as well as printer and imaging equipment, telecommunications systems, networking and communications infrastructure, industrial controls, and home entertainment and educational devices. Industrial-grade, extended temperature PowerPC 603e microprocessors are available for harsh operating environments. The PowerPC 603e microprocessor is software- and bus-compatible with the PowerPC 604e™, PowerPC 740™ and PowerPC 750™ microprocessor families.

Superscalar Microprocessor

The PowerPC 603e microprocessor is a superscalar design capable of issuing three instructions per clock cycle into five independent execution units, including:

- Integer unit
- Floating-point unit
- Branch processing unit
- Load/Store unit
- System register unit

The ability to execute multiple instructions in parallel, to pipeline instructions, and the use of simple instructions with rapid execution times yields maximum efficiency and throughput for PowerPC 603e systems.

Power Management

The PowerPC 603e microprocessor features a low-power 2.5-volt or 3.3-volt design with three power-saving modes—doze, nap and sleep. These user-programmable modes progressively reduce the power drawn by the processor.

The PowerPC 603e microprocessor also uses dynamic power management to selectively activate functional units as they are needed by the executing instructions. Unused functional units enter a low-power state automatically without affecting performance, software execution, or external hardware.

Cache and MMU Support

The PowerPC 603e microprocessor has separate 16-Kbyte, physically-addressed instruction and data caches. Both caches are four-way set-associative.

**PowerPC 603e Microprocessor
Block Diagram**

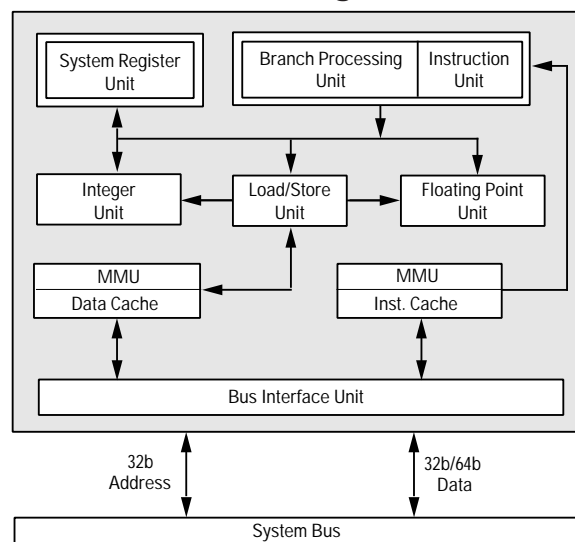

The PowerPC 603e microprocessor also contains separate memory management units (MMUs) for instructions and data. The MMUs support 4 Petabytes (2^{52}) of virtual memory and 4 Gigabytes (2^{32}) of physical memory. Access privileges and memory protection are controlled on block or page granularities. Large, 64-entry translation lookaside buffers (TLBs) provide efficient physical address translation and support for demand virtual-memory management on both page- and variable-sized blocks.

Flexible Bus Interface

The PowerPC 603e microprocessor has a selectable 32- or 64-bit data bus and a 32-bit address bus. Support is included for burst, split and pipelined transactions. The interface provides snooping for data cache coherency. The PowerPC 603e microprocessor maintains MEI coherency protocol in hardware, allowing access to system memory for additional caching bus masters, such as DMA devices.

PowerPC 603e CPU Summary

CPU	603e 100-133 MHz	603e 166-200 MHz	603e 200-300 MHz
CPU Speeds - Internal	100, 120 and 133 MHz	166, 180 and 200 MHz	250, 275 and 300 MHz
CPU Bus Dividers	x1.5, x2, x2.5, x3, x3.5, x4	x2, x2.5, x3, x3.5, x4, x4.5, x5, x5.5, x6	x2, x2.5, x3, x3.5, x4, x4.5, x5, x5.5, x6
Bus Interface	64-bit data & 32-bit address	64-bit data & 32-bit address	64-bit data & 32-bit address
Instructions per Clock	3 (2 + Branch)	3 (2 + Branch)	3 (2 + Branch)
L1 Cache	16-Kbyte instruction 16-Kbyte data	16-Kbyte instruction 16-Kbyte data	16-Kbyte instruction 16-Kbyte data
Typical/Maximum Power Dissipation	3.2W/4.0W @ 100 MHz	3.0W/4.0W @ 166 MHz	2.5W/4.0W @ 200 MHz
Die Size	98 mm ²	81 mm ²	42 mm ²
Package	240 CQFP, 255 CBGA	240 CQFP, 255 CBGA	255 CBGA
Process	0.5μ 4LM CMOS	0.35μ 5LM CMOS	0.29μ 5LM CMOS
Transistors	2.6 million	2.6 million	2.6 million
Voltage	3.3V	3.3V i/o, 2.5V internal	3.3V i/o, 2.5V internal
SPECint95 (estimated)	3.9 @ 133 MHz	5.6 @ 200 MHz	7.4 @ 300 MHz
SPECfp95 (estimated)	3.1 @ 133 MHz	4.9 @ 200 MHz	6.1 @ 300 MHz
Other Performance	188 MIPS @ 133 MHz	282 MIPS @ 200 MHz	423 MIPS @ 300 MHz
Execution Units	Integer, Floating-point, Branch, Load/Store, System Register	Integer, Floating-point, Branch, Load/Store, System Register	Integer, Floating-point, Branch, Load/Store, System Register

For additional information:
call 1-800-845-6686 or your local Motorola sales representative
or visit <http://motorola.com/PowerPC/>