

PowerPC™

Advance Information

PowerPC 603e™ RISC Microprocessor Family: PID7t-603e Hardware Specifications

The PowerPC 603e microprocessor is an implementation of the PowerPC™ family of reduced instruction set computing (RISC) microprocessors. In this document, the term '603e' is used as an abbreviation for 'PowerPC 603e microprocessor'. The PowerPC 603e microprocessors are available from Motorola as MPC603e and from IBM as PPC603e.

The 603e is implemented in several semiconductor fabrication processes. Different processes may require different supply voltages and may have other electrical differences but will have the same functionality. As a technical designator to distinguish between 603e implementations in various processes, a prefix composed of the processor version register (PVR) value and a process identifier (PID) is assigned to the various implementations as shown below:

PowerPC 603e Microprocessors from Motorola

Technical Designator	Process	Core Voltage	I/O Voltage	5-Volt Tolerant	Part Number
PID6-603e	0.5 μm CMOS, 4LM	3.3 V	3.3 V	Yes	MPC603e
PID7v-603e	0.35 μm CMOS, 5LM	2.5 V	3.3 V	Yes	MPC603p
PID7t-603e	0.25 μm CMOS, 5LM	2.5 V	3.3 V	Yes	MPC603r

The PowerPC name, the PowerPC logotype, and PowerPC 603e are trademarks of International Business Machines Corporation used by Motorola under license from International Business Machines Corporation.

This document contains information on a new product under development by Motorola. Motorola reserves the right to change or discontinue this product without notice.

© Motorola Inc. 1997. All rights reserved.

This document describes the pertinent physical characteristics of the PID7t-603e from Motorola. For functional characteristics of the 603e, refer to the *PowerPC 603e RISC Microprocessor User's Manual*.

This document contains the following topics:

Topic	Page
Section 1.1, "Overview"	2
Section 1.2, "Features"	3
Section 1.3, "General Parameters"	4
Section 1.4, "Electrical and Thermal Characteristics"	5
Section 1.5, "PowerPC 603e Microprocessor Pin Assignments"	17
Section 1.6, "PowerPC 603e Microprocessor Pinout Listings"	18
Section 1.7, "PowerPC 603e Microprocessor Package Descriptions"	20
Section 1.8, "System Design Information"	22
Section 1.9, "Ordering Information"	29

To locate any published errata or updates for this document, refer to the website at <http://www.mot.com/powerpc/>.

1.1 Overview

This section describes the features of the 603e and describes briefly how those units interact.

The 603e is a low-power implementation of the PowerPC microprocessor family of reduced instruction set computing (RISC) microprocessors. The 603e implements the 32-bit portion of the PowerPC architecture specification, which provides 32-bit effective addresses, integer data types of 8, 16, and 32 bits, and floating-point data types of 32 and 64 bits. For 64-bit PowerPC microprocessors, the PowerPC architecture provides 64-bit integer data types, 64-bit addressing, and other features required to complete the 64-bit architecture.

The 603e provides four software controllable power-saving modes. Three of the modes (the nap, doze, and sleep modes) are static in nature, and progressively reduce the amount of power dissipated by the processor. The fourth is a dynamic power management mode that causes the functional units in the 603e to automatically enter a low-power mode when the functional units are idle without affecting operational performance, software execution, or any external hardware.

The 603e is a superscalar processor capable of issuing and retiring as many as three instructions per clock. Instructions can execute out of order for increased performance; however, the 603e makes completion appear sequential.

The 603e integrates five execution units—an integer unit (IU), a floating-point unit (FPU), a branch processing unit (BPU), a load/store unit (LSU), and a system register unit (SRU). The ability to execute five instructions in parallel and the use of simple instructions with rapid execution times yield high efficiency and throughput for 603e-based systems. Most integer instructions execute in one clock cycle. The FPU is pipelined so a single-precision multiply-add instruction can be issued every clock cycle.

The 603e provides independent on-chip, 16-Kbyte, four-way set-associative, physically addressed caches for instructions and data and on-chip instruction and data memory management units (MMUs). The MMUs contain 64-entry, two-way set-associative, data and instruction translation lookaside buffers (DTLB and ITLB) that provide support for demand-paged virtual memory address translation and variable-sized block translation. The TLBs and caches use a least-recently used (LRU) replacement algorithm. The 603e also supports block address translation through the use of two independent instruction and data block address translation (IBAT and DBAT) arrays of four entries each. Effective addresses are compared simultaneously with all four entries in the BAT array during block translation. In accordance with the PowerPC architecture,

if an effective address hits in both the TLB and BAT array, the BAT translation takes priority.

The 603e has a selectable 32- or 64-bit data bus and a 32-bit address bus. The 603e interface protocol allows multiple masters to compete for system resources through a central external arbiter. The 603e provides a three-state coherency protocol that supports the exclusive, modified, and invalid cache states. This protocol is a compatible subset of the MESI (modified/exclusive/shared/invalid) four-state protocol and operates coherently in systems that contain four-state caches. The 603e supports single-beat and burst data transfers for memory accesses, and supports memory-mapped I/O.

The 603e uses an advanced, 2.5/3.3-V CMOS process technology and maintains full interface compatibility with TTL devices.

1.2 Features

This section summarizes features of the 603e's implementation of the PowerPC architecture. Major features of the 603e are as follows:

- High-performance, superscalar microprocessor
 - As many as three instructions issued and retired per clock
 - As many as five instructions in execution per clock
 - Single-cycle execution for most instructions
 - Pipelined FPU for all single-precision and most double-precision operations
- Five independent execution units and two register files
 - BPU featuring static branch prediction
 - A 32-bit IU
 - Fully IEEE 754-compliant FPU for both single- and double-precision operations
 - LSU for data transfer between data cache and GPRs and FPRs
 - SRU that executes condition register (CR), special-purpose register (SPR) instructions, and integer add/compare instructions
 - Thirty-two GPRs for integer operands
 - Thirty-two FPRs for single- or double-precision operands
- High instruction and data throughput
 - Zero-cycle branch capability (branch folding)
 - Programmable static branch prediction on unresolved conditional branches
 - Instruction fetch unit capable of fetching two instructions per clock from the instruction cache
 - A six-entry instruction queue that provides lookahead capability
 - Independent pipelines with feed-forwarding that reduces data dependencies in hardware
 - 16-Kbyte data cache—four-way set-associative, physically addressed; LRU replacement algorithm
 - 16-Kbyte instruction cache—four-way set-associative, physically addressed; LRU replacement algorithm
 - Cache write-back or write-through operation programmable on a per page or per block basis
 - BPU that performs CR lookahead operations
 - Address translation facilities for 4-Kbyte page size, variable block size, and 256-Mbyte segment size

- A 64-entry, two-way set-associative ITLB
- A 64-entry, two-way set-associative DTLB
- Four-entry data and instruction BAT arrays providing 128-Kbyte to 256-Mbyte blocks
- Software table search operations and updates supported through fast trap mechanism
- 52-bit virtual address; 32-bit physical address
- Facilities for enhanced system performance
 - A 32- or 64-bit split-transaction external data bus with burst transfers
 - Support for one-level address pipelining and out-of-order bus transactions
- Integrated power management
 - Low-power 2.5/3.3-volt design
 - Internal processor/bus clock multiplier that provides 2/1, 2.5/1, 3/1, 3.5/1, 4/1, 4.5/1, 5/1, 5.5/1, and 6/1 ratios
 - Three power saving modes: doze, nap, and sleep
 - Automatic dynamic power reduction when internal functional units are idle
- In-system testability and debugging features through JTAG boundary-scan capability

1.3 General Parameters

The following list provides a summary of the general parameters of the PID7t-603e:

Technology	0.25 μm CMOS, five-layer metal
Die size	5.65 mm x 7.7 mm (44 mm ²)
Transistor count	2.6 million
Logic design	Fully-static
Package	255 ceramic ball grid array (CBGA)
Core power supply	2.5 \pm 5% V dc
I/O power supply	3.3 \pm 5% V dc

1.4 Electrical and Thermal Characteristics

This section provides the AC and DC electrical specifications and thermal characteristics for the PID7t-603e.

1.4.1 DC Electrical Characteristics

The tables in this section describe the PID7t-603e DC electrical characteristics. Table 1 provides the absolute maximum ratings.

Table 1. Absolute Maximum Ratings

Characteristic	Symbol	Value	Unit
Core supply voltage	V _{dd}	-0.3 to 2.75	V
PLL supply voltage	AV _{dd}	-0.3 to 2.75	V
I/O supply voltage	OV _{dd}	-0.3 to 3.6	V
Input voltage	V _{in}	-0.3 to 5.5	V
Storage temperature range	T _{stg}	-55 to 150	°C

Notes:

1. Functional and tested operating conditions are given in Table 2. Absolute maximum ratings are stress ratings only, and functional operation at the maximums is not guaranteed. Stresses beyond those listed may affect device reliability or cause permanent damage to the device.
2. **Caution:** V_{in} must not exceed OV_{dd} by more than 2.5 V at any time, including during power-on reset.
3. **Caution:** OV_{dd} must not exceed V_{dd}/AV_{dd} by more than 1.2 V at any time, including during power-on reset.
4. **Caution:** V_{dd}/AV_{dd} must not exceed OV_{dd} by more than 0.4 V at any time, including during power-on reset.

Table 2 provides the recommended operating conditions for the PID7t-603e.

Table 2. Recommended Operating Conditions

Characteristic	Symbol	Value	Unit
Core supply voltage	V _{dd}	2.375 to 2.625	V
PLL supply voltage	AV _{dd}	2.375 to 2.625	V
I/O supply voltage	OV _{dd}	3.135 to 3.465	V
Input voltage	V _{in}	GND to 5.5	V
Die-junction temperature	T _j	0 to 105	°C

Note: These are the recommended and tested operating conditions. Proper device operation outside of these conditions is not guaranteed.

Table 3 provides the package thermal characteristics for the PID7t-603e.

Table 3. Package Thermal Characteristics

Characteristic	Symbol	Value	Rating
CBGA package die junction-to-case thermal resistance (typical)	θ_{JC}	0.095	°C/W
CBGA package die junction-to-ball thermal resistance (typical)	θ_{JB}	3.5	°C/W

Note: Refer to Section 1.8, “System Design Information,” for more details about thermal management.

Table 4 provides the DC electrical characteristics for the PID7t-603e.

Table 4. DC Electrical Specifications

Vdd = AVdd = 2.5 ± 5% V dc, OVdd = 3.3 ± 5% V dc, GND = 0 V dc, 0 ≤ Tj ≤ 105 °C

Characteristic	Symbol	Min	Max	Unit	Notes
Input high voltage (all inputs except SYSCLK)	V _{IH}	2.0	5.5	V	
Input low voltage (all inputs except SYSCLK)	V _{IL}	GND	0.8	V	
SYSCLK input high voltage	CV _{IH}	2.4	5.5	V	
SYSCLK input low voltage	CV _{IL}	GND	0.4	V	
Input leakage current, V _{in} = 3.465 V	I _{in}	—	30	μA	1,2
V _{in} = 5.5 V	I _{in}	—	300	μA	1,2
Hi-Z (off-state) leakage current, V _{in} = 3.465 V	I _{TSI}	—	30	μA	1,2
V _{in} = 5.5 V	I _{TSI}	—	300	μA	1,2
Output high voltage, I _{OH} = -7 mA	V _{OH}	2.4	—	V	
Output low voltage, I _{OL} = 7 mA	V _{OL}	—	0.4	V	
Capacitance, V _{in} = 0 V, f = 1 MHz (excludes \overline{TS} , \overline{ABB} , \overline{DBB} , and \overline{ARTRY})	C _{in}	—	10.0	pF	3
Capacitance, V _{in} = 0 V, f = 1 MHz (for \overline{TS} , \overline{ABB} , \overline{DBB} , and \overline{ARTRY})	C _{in}	—	15.0	pF	3

Notes:

1. Excludes test signals (LSSD_MODE, L1_TSTCLK, L2_TSTCLK, and JTAG signals).
2. The leakage is measured for nominal OVdd and Vdd or both OVdd and Vdd must vary in the same direction (for example, both OVdd and Vdd vary by either +5% or -5%).
3. Capacitance is periodically sampled rather than 100% tested.

Table 5 provides the power consumption for the PID7t-603e.

Table 5. Power Consumption

	Processor (CPU) Frequency						Unit
	200 MHz	225 MHz	240 MHz	250 MHz	275 MHz	300 MHz	
Full-On Mode (DPM Enabled)							
Typical	2.5	3.0	3.2	3.3	3.6	4.0	W
Maximum	4.0	4.5	4.8	5.0	5.5	6.0	W
Doze Mode							
Typical	1.7	1.8	1.86	1.9	2.0	2.1	W
Nap Mode							
Typical	120	135	144	150	165	180	mW
Sleep Mode							
Typical	110	120	128	130	140	150	mW
Sleep Mode—PLL Disabled							
Typical	60	60	60	60	60	60	mW
Sleep Mode—PLL and SYSCLK Disabled							
Typical	25	25	25	25	25	25	mW
Maximum	60	60	60	70	80	100	mW

Notes:

1. These values apply for all valid PLL_CFG[0–3] settings and do not include output driver power (OVdd) or analog supply power (AVdd). OVdd power is system dependent but is typically $\leq 10\%$ of Vdd. Worst-case AVdd = 15 mW.
2. Typical power is an average value measured at Vdd = AVdd = 2.5 V, OVdd = 3.3V, in a system executing typical applications and benchmark sequences.
3. Maximum power is measured at 2.625 V using a worst-case instruction mix.

1.4.2 AC Electrical Characteristics

This section provides the AC electrical characteristics for the PID7t-603e. These specifications are for 200, 225, 240, 250, 275 and 300 MHz processor core frequencies. The processor core frequency is determined by the bus (SYSCLK) frequency and the settings of the PLL_CFG[0–3] signals. All timings are specified relative to the rising edge of SYSCLK. PLL_CFG signals should be set prior to power up and not altered afterwards.

1.4.2.1 Clock AC Specifications

Table 6 provides the clock AC timing specifications as defined in Figure 1. After fabrication, parts are sorted by maximum processor core frequency as shown in Section 1.4.2.1, “Clock AC Specifications,” and tested for conformance to the AC specifications for that frequency. Parts are sold by maximum processor core frequency; see Section 1.9, “Ordering Information.”

Table 6. Clock AC Timing Specifications

Vdd = AVdd = 2.5 ± 5% V dc, OVdd = 3.3 ± 5% V dc, GND = 0 V dc, 0 ≤ Tj ≤ 105 °C

Num	Characteristic	200 MHz		225 MHz		240 MHz		250 MHz		275 MHz		300 MHz		Unit	Notes
		Min	Max	Min	Max	Min	Max	Min	Max	Min	Max	Min	Max		
	Processor frequency	180	200	180	225	180	240	180	250	180	275	180	300	MHz	1
	VCO frequency	360	400	360	450	360	480	360	500	360	550	360	600	MHz	1
	SYSCLK frequency	33.3	66.67	33.3	75	33.3	75	33.3	75	33.3	75	33.3	75	MHz	1
1	SYSCLK cycle time	15	30	13.3	30	13.3	30	13.3	30	13.3	30	13.3	30	ns	
2,3	SYSCLK rise and fall time	—	2.0	—	2.0	—	2.0	—	2.0	—	2.0	—	2.0	ns	2
4	SYSCLK duty cycle measured at 1.4 V	40.0	60.0	40.0	60.0	40.0	60.0	40.0	60.0	40.0	60.0	40.0	60.0	%	3
	SYSCLK jitter	—	±150	—	±150	—	±150	—	±150	—	±150	—	±150	ps	4
	603e internal PLL-relock time	—	100	—	100	—	100	—	100	—	100	—	100	μs	3,5

Notes:

- Caution:** The SYSCLK frequency and PLL_CFG[0–3] settings must be chosen such that the resulting SYSCLK (bus) frequency, CPU (core) frequency, and PLL (VCO) frequency do not exceed their respective maximum or minimum operating frequencies. Refer to the PLL_CFG[0–3] signal description in Section 1.8, “System Design Information,” for valid PLL_CFG[0–3] settings.
- Rise and fall times for the SYSCLK input are measured from 0.4 V to 2.4 V.
- Timing is guaranteed by design and characterization, and is not tested.
- Cycle-to-cycle jitter, and is guaranteed by design. The total input jitter (short term and long term combined) must be under ±150 ps to guarantee the input/output timing of Section 1.4.2.2, “Input AC Specifications,” and Section 1.4.2.3, “Output AC Specifications.”
- Relock timing is guaranteed by design and characterization, and is not tested. PLL-relock time is the maximum time required for PLL lock after a stable Vdd, OVdd, AVdd, and SYSCLK are reached during the power-on reset sequence. This specification also applies when the PLL has been disabled and subsequently re-enabled during sleep mode. Also note that $\overline{\text{HRESET}}$ must be held asserted for a minimum of 255 bus clocks after the PLL-relock time (100 μs) during the power-on reset sequence.

Figure 1 provides the SYSCLK input timing diagram.

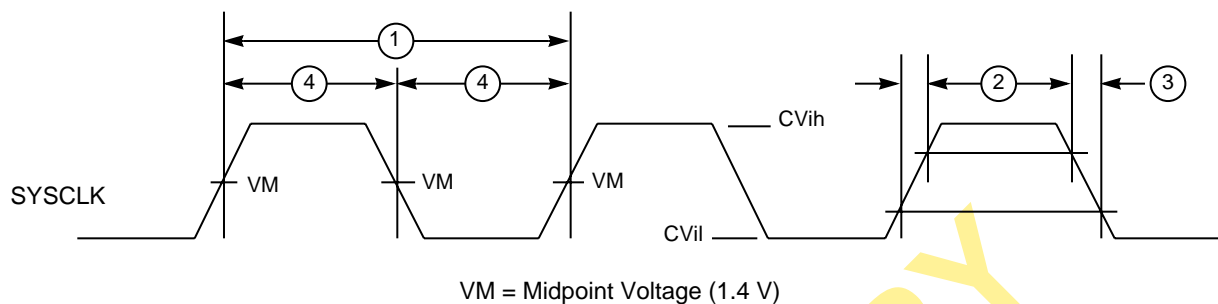

Figure 1. SYSCLK Input Timing Diagram

1.4.2.2 Input AC Specifications

Table 7 provides the input AC timing specifications for the PID7t-603e as defined in Figure 2 and Figure 3.

Table 7. Input AC Timing Specifications¹

Vdd = AVdd = 2.5 ± 5% V dc, OVdd = 3.3 ± 5% V dc, GND = 0 V dc, 0 ≤ Tj ≤ 105° C

Num	Characteristic	200 MHz		225, 240, 250, 275, 300 MHz		Unit	Notes
		Min	Max	Min	Max		
10a	Address/data/transfer attribute inputs valid to SYSCLK (input setup)	2.5	—	2.5	—	ns	2
10b	All other inputs valid to SYSCLK (input setup)	4.0	—	3.5	—	ns	3
10c	Mode select inputs valid to HRESET (input setup) (for DRTRY, QACK and TLBISYNC)	8	—	8	—	t _{sysclk}	4, 5, 6, 7
11a	SYSCLK to address/data/transfer attribute inputs invalid (input hold)	1.0	—	1.0	—	ns	2

Table 7. Input AC Timing Specifications¹ (Continued)

V_{dd} = AV_{dd} = 2.5 ± 5% V dc, OV_{dd} = 3.3 ± 5% V dc, GND = 0 V dc, 0 ≤ T_j ≤ 105° C

Num	Characteristic	200 MHz		225, 240, 250, 275, 300 MHz		Unit	Notes
		Min	Max	Min	Max		
11b	SYSCLK to all other inputs invalid (input hold)	1.0	—	1.0	—	ns	3
11c	$\overline{\text{HRESET}}$ to mode select inputs invalid (input hold) (for DRTRY, QACK, and TLBISYNC)	0	—	0	—	ns	4, 6, 7

Notes:

1. Input specifications are measured from the TTL level (0.8 or 2.0 V) of the signal in question to the 1.4 V of the rising edge of the input SYSCLK. Input and output timings are measured at the pin.
2. Address/data/transfer attribute input signals are composed of the following—A[0–31], AP[0–3], TT[0–4], TC[0–1], TBST, TSIZ[0–2], GBL, DH[0–31], DL[0–31], DP[0–7].
3. All other input signals are composed of the following— $\overline{\text{TS}}$, $\overline{\text{ABB}}$, $\overline{\text{DBB}}$, $\overline{\text{ARTRY}}$, $\overline{\text{BG}}$, $\overline{\text{AACK}}$, $\overline{\text{DBG}}$, $\overline{\text{DBWO}}$, $\overline{\text{TA}}$, $\overline{\text{DRTRY}}$, $\overline{\text{TEA}}$, $\overline{\text{DBDIS}}$, $\overline{\text{HRESET}}$, $\overline{\text{SRESET}}$, $\overline{\text{INT}}$, $\overline{\text{SMI}}$, $\overline{\text{MCP}}$, $\overline{\text{TBEN}}$, $\overline{\text{QACK}}$, $\overline{\text{TLBISYNC}}$.
4. The setup and hold time is with respect to the rising edge of $\overline{\text{HRESET}}$ (see Figure 3).
5. t_{sysclk} is the period of the external clock (SYSCLK) in nanoseconds (ns). The numbers given in the table must be multiplied by the period of SYSCLK to compute the actual time duration (in nanoseconds) of the parameter in question.
6. These values are guaranteed by design, and are not tested.
7. This specification is for configuration mode only. Also note that $\overline{\text{HRESET}}$ must be held asserted for a minimum of 255 bus clocks after the PLL-relock time during the power-on reset sequence.

Figure 2 provides the input timing diagram for the PID7t-603e.

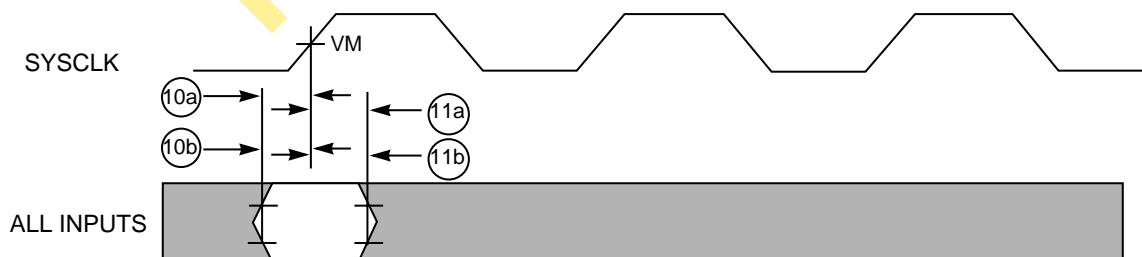

VM = Midpoint Voltage (1.4 V)

Figure 2. Input Timing Diagram

Figure 3 provides the mode select input timing diagram for the PID7t-603e.

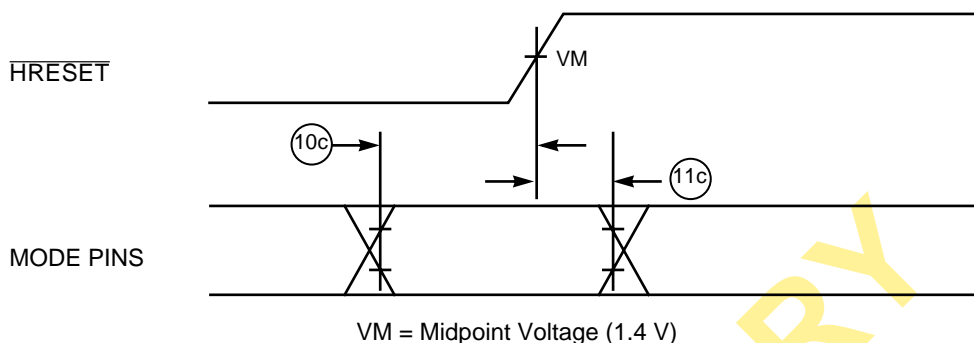

Figure 3. Mode Select Input Timing Diagram

1.4.2.3 Output AC Specifications

Table 8 provides the output AC timing specifications for the PID7t-603e as defined in Figure 4.

Table 8. Output AC Timing Specifications¹

V_{dd} = AV_{dd} = 2.5 ± 5% V dc, OV_{dd} = 3.3 ± 5%, GND = 0 V dc, 0 ≤ T_j ≤ 105 °C, C_L = 50 pF (unless otherwise noted)

Num	Characteristic	200 MHz		225, 240, 250, 275, 300 MHz		Unit	Notes
		Min	Max	Min	Max		
12	SYSCLK to output driven (output enable time)	1.0	—	1.0	—	ns	
13a	SYSCLK to output valid (5.5 V to 0.8 V— \overline{TS} , \overline{ABB} , \overline{ARTRY} , \overline{DBB})	—	9.0	—	9.0	ns	3
13b	SYSCLK to output valid (\overline{TS} , \overline{ABB} , \overline{ARTRY} , \overline{DBB})	—	8.0	—	8.0	ns	5
14a	SYSCLK to output valid (5.5 V to 0.8 V—all except \overline{TS} , \overline{ABB} , \overline{ARTRY} , \overline{DBB})	—	11.0	—	11.0	ns	3
14b	SYSCLK to output valid (all except \overline{TS} , \overline{ABB} , \overline{ARTRY} , \overline{DBB})	—	9.0	—	9.0	ns	5
15	SYSCLK to output invalid (output hold)	1.0	—	1.0	—	ns	2
16	SYSCLK to output high impedance (all except \overline{ARTRY} , \overline{ABB} , \overline{DBB})	—	8.5	—	8.0	ns	
17	SYSCLK to \overline{ABB} , \overline{DBB} , high impedance after precharge	—	1.0	—	1.0	t _{sysclk}	4, 6
18	SYSCLK to \overline{ARTRY} high impedance before precharge	—	8.0	—	7.5	ns	

Table 8. Output AC Timing Specifications¹ (Continued)

V_{dd} = AV_{dd} = 2.5 ± 5% V dc, OV_{dd} = 3.3 ± 5%, GND = 0 V dc, 0 ≤ T_J ≤ 105 °C, C_L = 50 pF (unless otherwise noted)

Num	Characteristic	200 MHz		225, 240, 250, 275, 300 MHz		Unit	Notes
		Min	Max	Min	Max		
19	SYSClk to $\overline{\text{ARTRY}}$ precharge enable	0.2 * $t_{\text{sysclk}} + 1.0$	—	0.2 * $t_{\text{sysclk}} + 1.0$	—	ns	2, 4, 7
20	Maximum delay to $\overline{\text{ARTRY}}$ precharge	—	1.0	—	1.0	t_{sysclk}	4, 7
21	SYSClk to $\overline{\text{ARTRY}}$ high impedance after precharge	—	2.0	—	2.0	t_{sysclk}	5, 7

Notes:

1. All output specifications are measured from the 1.4 V of the rising edge of SYSClk to the TTL level (0.8 V or 2.0 V) of the signal in question. Both input and output timings are measured at the pin (see Figure 4).
2. This minimum parameter assumes C_L = 0 pF.
3. SYSClk to output valid (5.5 V to 0.8 V) includes the extra delay associated with discharging the external voltage from 5.5 V to 0.8 V instead of from V_{dd} to 0.8 V (5-V CMOS levels instead of 3.3-V CMOS levels).
4. t_{sysclk} is the period of the external bus clock (SYSClk) in nanoseconds (ns). The numbers given in the table must be multiplied by the period of SYSClk to compute the actual time duration (in nanoseconds) of the parameter in question.
5. Output signal transitions from GND to 2.0 V or V_{dd} to 0.8 V.
6. Nominal precharge width for $\overline{\text{ABB}}$ and $\overline{\text{DBB}}$ is 0.5 t_{sysclk} .
7. Nominal precharge width for $\overline{\text{ARTRY}}$ is 1.0 t_{sysclk} .

Figure 4 provides the output timing diagram for the PID7t-603e.

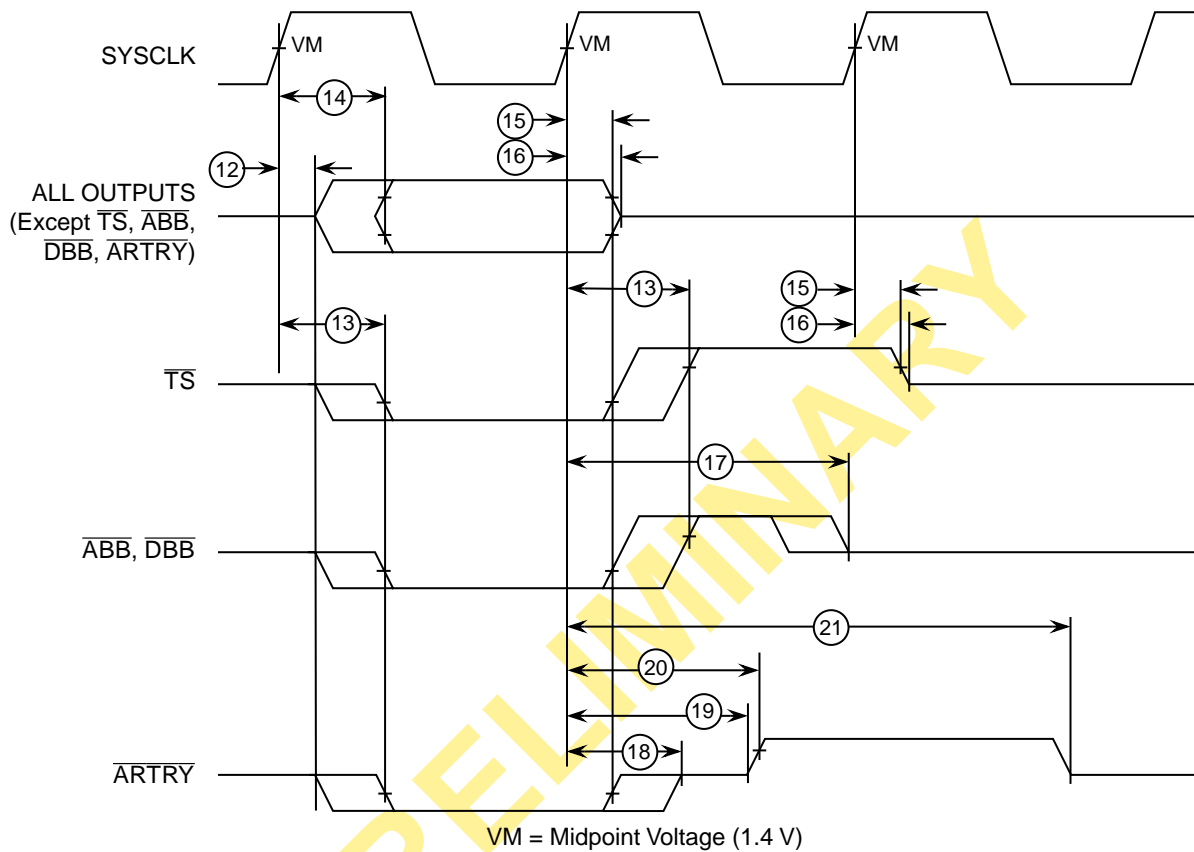

Figure 4. Output Timing Diagram

1.4.3 JTAG AC Timing Specifications

Table 9 provides the JTAG AC timing specifications as defined in Figure 5, Figure 6, Figure 7 and Figure 8.

Table 9. JTAG AC Timing Specifications

Vdd = AVdd = 2.5 ± 5% V dc, OVdd = 3.3 ± 5%, GND = 0 V dc, 0 ≤ Tj ≤ 105° C, CL = 50 pF

Num	Characteristic	Min	Max	Unit	Notes
	TCK frequency of operation	0	16	MHz	
1	TCK cycle time	62.5	—	ns	
2	TCK clock pulse width measured at 1.4 V	25	—	ns	
3	TCK rise and fall times	0	3	ns	
4	$\overline{\text{TRST}}$ setup time to TCK rising edge	13	—	ns	1
5	$\overline{\text{TRST}}$ assert time	40	—	ns	
6	Boundary scan input data setup time	6	—	ns	2
7	Boundary scan input data hold time	27	—	ns	2
8	TCK to output data valid	4	25	ns	3
9	TCK to output high impedance	3	24	ns	3
10	TMS, TDI data setup time	0	—	ns	
11	TMS, TDI data hold time	25	—	ns	
12	TCK to TDO data valid	4	24	ns	
13	TCK to TDO high impedance	3	15	ns	

Notes:

1. $\overline{\text{TRST}}$ is an asynchronous signal. The setup time is for test purposes only.
2. Non-test signal input timing with respect to TCK.
3. Non-test signal output timing with respect to TCK.

Figure 5 provides the JTAG clock input timing diagram.

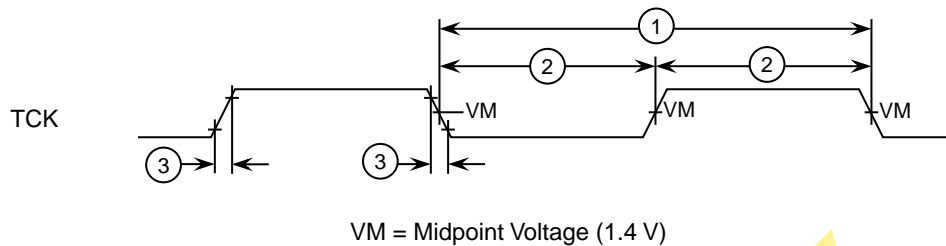

Figure 5. JTAG Clock Input Timing Diagram

Figure 6 provides the $\overline{\text{TRST}}$ timing diagram.

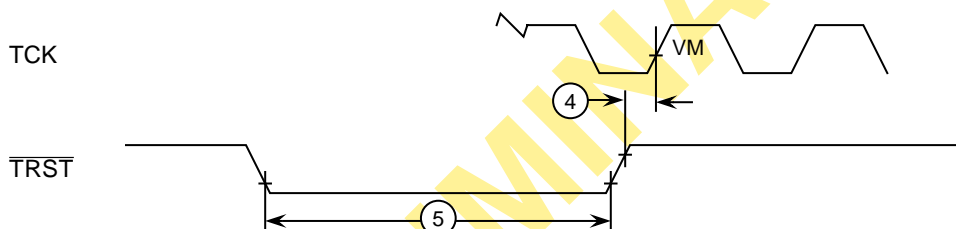

Figure 6. $\overline{\text{TRST}}$ Timing Diagram

Figure 7 provides the boundary-scan timing diagram.

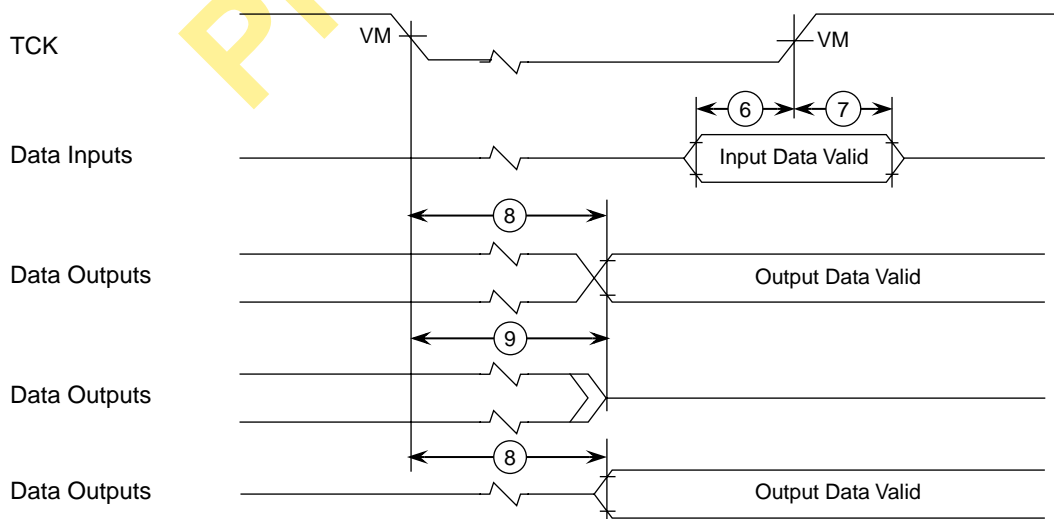

Figure 7. Boundary-Scan Timing Diagram

Figure 8 provides the test access port timing diagram.

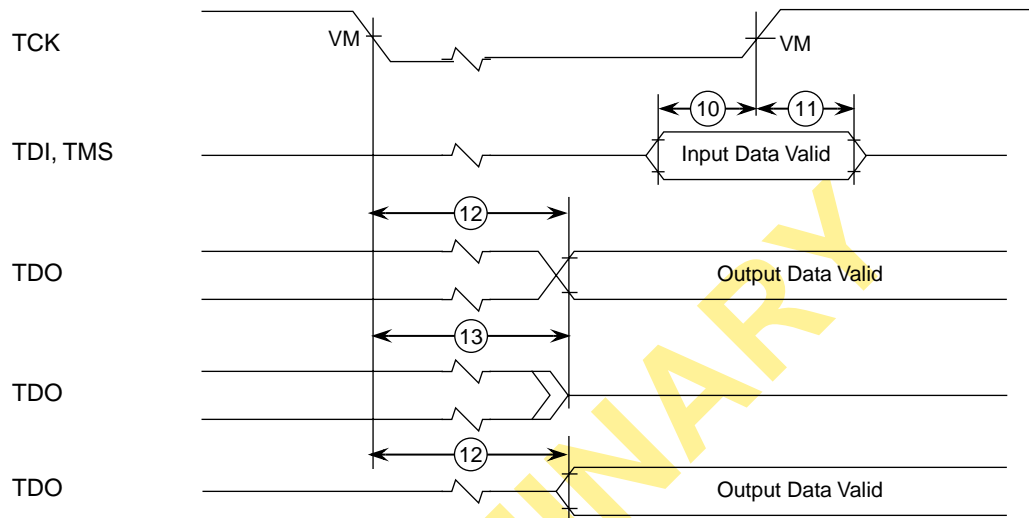
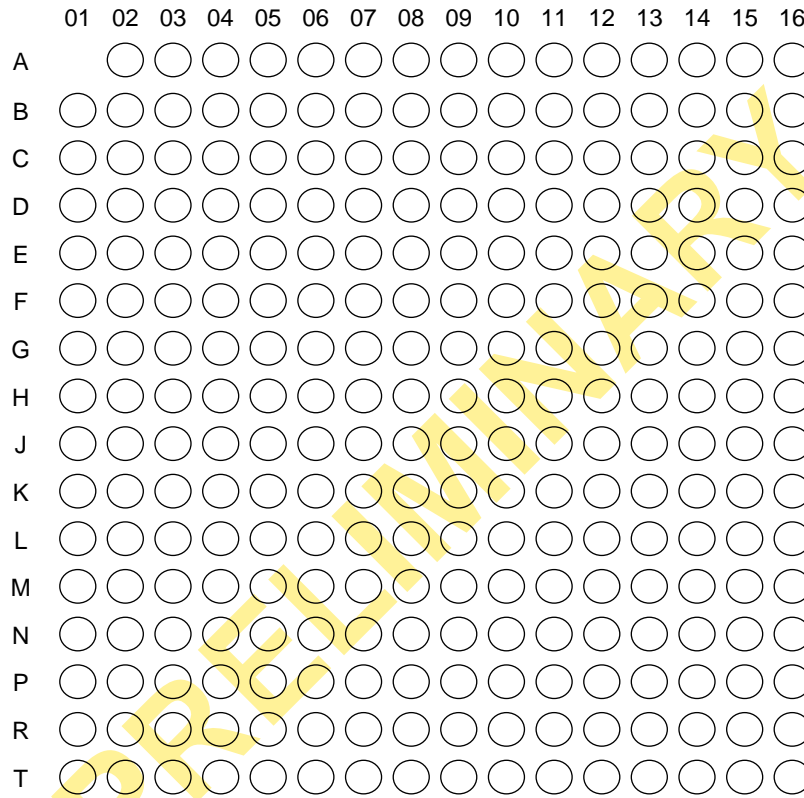

Figure 8. Test Access Port Timing Diagram

1.5 PowerPC 603e Microprocessor Pin Assignments

Figure 9 (in part A) shows the pinout of the CBGA package as viewed from the top surface. Part B shows the side profile of the CBGA package to indicate the direction of the top surface view.

Part A



Not to Scale

Part B

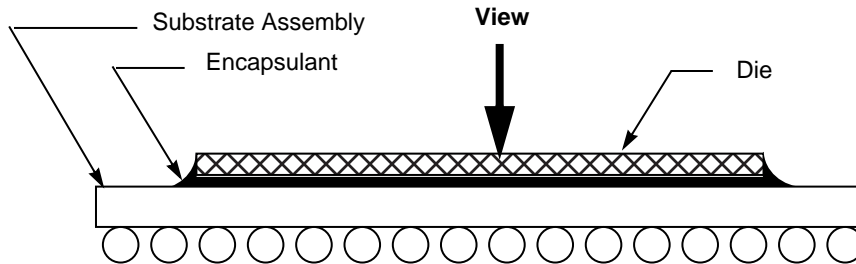

Figure 9. Pinout of the CBGA Package as Viewed from the Top Surface

1.6 PowerPC 603e Microprocessor Pinout Listings

Table 10 provides the pinout listing for the 603e CBGA package.

Table 10. Pinout Listing for the 255-Pin CBGA Package

Signal Name	Pin Number	Active	I/O
A[0–31]	C16, E04, D13, F02, D14, G01, D15, E02, D16, D04, E13, G02, E15, H01, E16, H02, F13, J01, F14, J02, F15, H03, F16, F04, G13, K01, G15, K02, H16, M01, J15, P01	High	I/O
$\overline{\text{AACK}}$	L02	Low	Input
ABB	K04	Low	I/O
AP[0–3]	C01, B04, B03, B02	High	I/O
$\overline{\text{APE}}$	A04	Low	Output
$\overline{\text{ARTRY}}$	J04	Low	I/O
AVDD	A10	—	—
$\overline{\text{BG}}$	L01	Low	Input
BR	B06	Low	Output
$\overline{\text{CI}}$	E01	Low	Output
$\overline{\text{CKSTP_IN}}$	D08	Low	Input
$\overline{\text{CKSTP_OUT}}$	A06	Low	Output
CLK_OUT	D07	—	Output
CSE[0–1]	B01, B05	High	Output
DBB	J14	Low	I/O
$\overline{\text{DBG}}$	N01	Low	Input
$\overline{\text{DBDIS}}$	H15	Low	Input
$\overline{\text{DBW}\overline{\text{O}}}$	G04	Low	Input
DH[0–31]	P14, T16, R15, T15, R13, R12, P11, N11, R11, T12, T11, R10, P09, N09, T10, R09, T09, P08, N08, R08, T08, N07, R07, T07, P06, N06, R06, T06, R05, N05, T05, T04	High	I/O
DL[0–31]	K13, K15, K16, L16, L15, L13, L14, M16, M15, M13, N16, N15, N13, N14, P16, P15, R16, R14, T14, N10, P13, N12, T13, P03, N03, N04, R03, T01, T02, P04, T03, R04	High	I/O
DP[0–7]	M02, L03, N02, L04, R01, P02, M04, R02	High	I/O
$\overline{\text{DPE}}$	A05	Low	Output
$\overline{\text{DRTRY}}$	G16	Low	Input
$\overline{\text{GBL}}$	F01	Low	I/O
GND	C05, C12, E03, E06, E08, E09, E11, E14, F05, F07, F10, F12, G06, G08, G09, G11, H05, H07, H10, H12, J05, J07, J10, J12, K06, K08, K09, K11, L05, L07, L10, L12, M03, M06, M08, M09, M11, M14, P05, P12	—	—

Table 10. Pinout Listing for the 255-Pin CBGA Package (Continued)

Signal Name	Pin Number	Active	I/O
HRESET	A07	Low	Input
INT	B15	Low	Input
L1_TSTCLK ¹	D11	—	Input
L2_TSTCLK ¹	D12	—	Input
LSSD_MODE ¹	B10	Low	Input
MCP	C13	Low	Input
NC (No-Connect)	B07, B08, C03, C06, C08, D05, D06, H04, J16	—	—
OVDD	C07, E05, E07, E10, E12, G03, G05, G12, G14, K03, K05, K12, K14, M05, M07, M10, M12, P07, P10	—	—
PLL_CFG[0–3]	A08, B09, A09, D09	High	Input
QACK	D03	Low	Input
QREQ	J03	Low	Output
RSRV	D01	Low	Output
SMI	A16	Low	Input
SRESET	B14	Low	Input
SYSCLK	C09	—	Input
TA	H14	Low	Input
TBEN	C02	High	Input
TBST	A14	Low	I/O
TC[0–1]	A02, A03	High	Output
TCK	C11	—	Input
TDI	A11	High	Input
TDO	A12	High	Output
TEA	H13	Low	Input
TLBISYNC	C04	Low	Input
TMS	B11	High	Input
TRST	C10	Low	Input
TS	J13	Low	I/O
TSIZ[0–2]	A13, D10, B12	High	Output
TT[0–4]	B13, A15, B16, C14, C15	High	I/O

Table 10. Pinout Listing for the 255-Pin CBGA Package (Continued)

Signal Name	Pin Number	Active	I/O
\overline{WT}	D02	Low	Output
VDD ²	F06, F08, F09, F11, G07, G10, H06, H08, H09, H11, J06, J08, J09, J11, K07, K10, L06, L08, L09, L11	—	—
VOLTDETGND ³	F03	Low	Output

Notes:

1. These are test signals for factory use only and must be pulled up to OVdd for normal machine operation.
2. OVdd inputs supply power to the I/O drivers and Vdd inputs supply power to the processor core.
3. NC (no-connect) in the PID6-603e; internally tied to GND in the PID7v-603e and PID7t-603e CBGA package to indicate to the power supply that a low-voltage processor is present.

1.7 PowerPC 603e Microprocessor Package Descriptions

The following sections provide the package parameters and the mechanical dimensions for the 603e. Note that the PID7t-603e is currently offered only in the ceramic ball grid array (CBGA) package.

1.7.1 CBGA Package Description

The following sections provide the package parameters and mechanical dimensions for the CBGA package.

1.7.1.1 Package Parameters

The package parameters are as provided in the following list. The package type is 21 mm x 21 mm, 255-lead ceramic ball grid array (CBGA).

Package outline	21 mm x 21 mm
Interconnects	255
Pitch	1.27 mm (50 mil)
Package height	Minimum: 2.45 mm Maximum: 3.00 mm
Ball diameter	0.89 mm (35 mil)
Maximum heat sink force	10 lbs

1.7.1.2 Mechanical Dimensions of the CBGA Package

Figure 10 provides the mechanical dimensions and bottom surface nomenclature of the CBGA package.

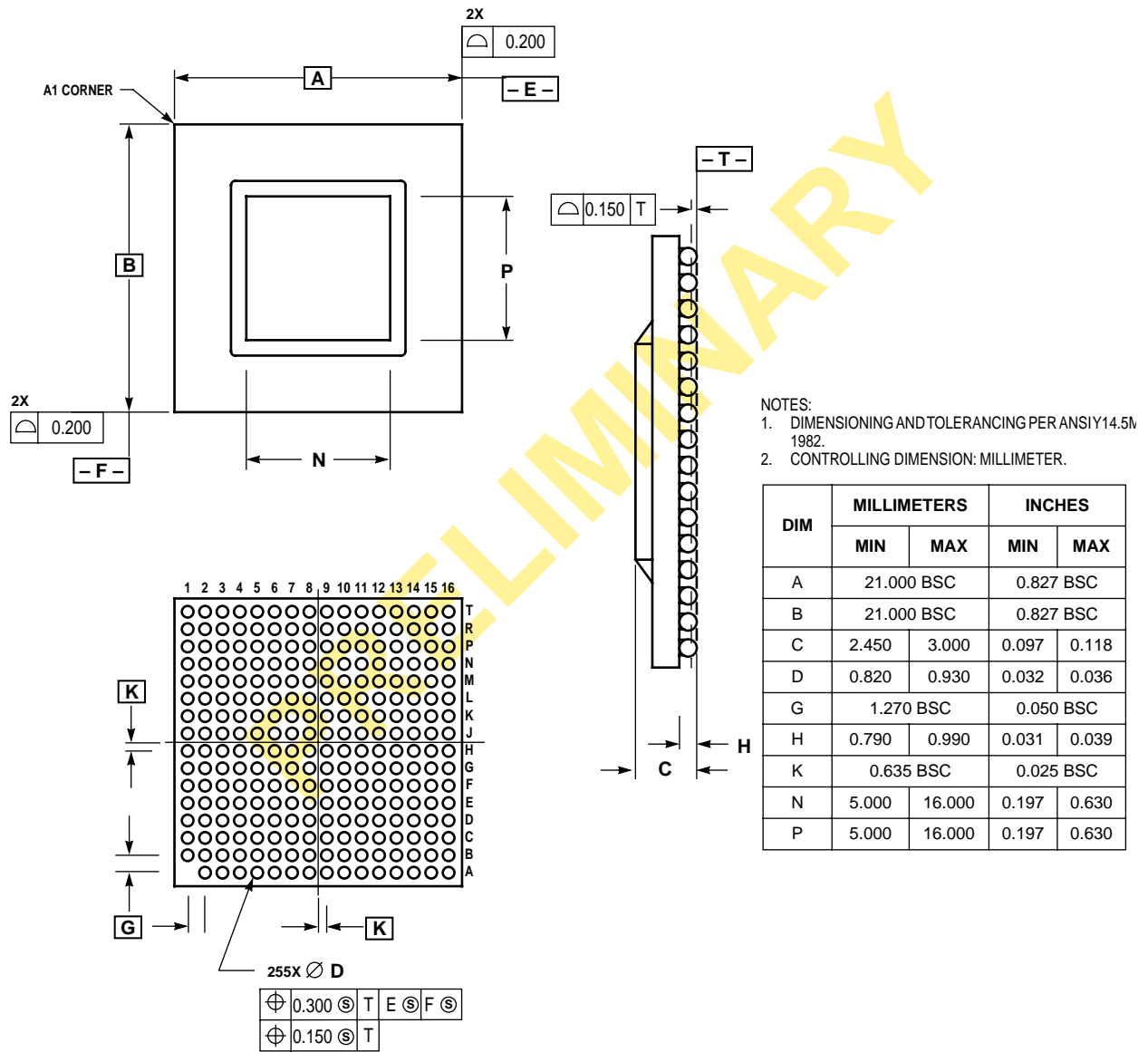

Figure 10. Mechanical Dimensions and Bottom Surface Nomenclature of the CBGA Package

1.8 System Design Information

This section provides electrical and thermal design recommendations for successful application of the 603e.

1.8.1 PLL Configuration

The 603e PLL is configured by the PLL_CFG[0–3] signals. For a given SYSCLK (bus) frequency, the PLL configuration signals set the internal CPU and VCO frequency of operation. The PLL configuration for the PID7t-603e is shown in Table 11 for nominal frequencies.

Table 11. PLL Configuration

PLL_CFG[0–3]	CPU Frequency in MHz (VCO Frequency in MHz)								
	Bus-to-Core Multiplier	Core-to VCO Multiplier	Bus 25 MHz	Bus 33.33 MHz	Bus 40 MHz	Bus 50 MHz	Bus 60 MHz	Bus 66.67 MHz	Bus 75 MHz
0100	2x	2x	—	—	—	—	—	133 (266)	150 (300)
0101	2x	4x	—	—	—	—	—	—	—
0110	2.5x	2x	—	—	—	125 (250)	150 (300)	166 (333)	187 (375)
1000	3x	2x	—	—	—	150 (300)	180 (360)	200 (400)	225 (450)
1110	3.5x	2x	—	—	140 (280)	175 (350)	210 (420)	233 (466)	263 (525)
1010	4x	2x	—	133 (266)	160 (320)	200 (400)	240 (480)	267 (533)	300 (600)
0111	4.5x	2x	—	150 (300)	180 (360)	225 (450)	270 (540)	300 (600)	—
1011	5x	2x	125 (250)	166 (333)	200 (400)	250 (500)	300 (600)	—	—
1001	5.5x	2x	137 (275)	183 (366)	220 (440)	275 (550)	—	—	—
1101	6x	2x	150 (300)	200 (400)	240 (480)	300 (600)	—	—	—
0011	PLL bypass								
1111	Clock off								

Notes:

- Some PLL configurations may select bus, CPU, or VCO frequencies which are not supported; see Section 1.4.2.1, “Clock AC Specifications,” for valid SYSCLK and VCO frequencies.
- In PLL-bypass mode, the SYSCLK input signal clocks the internal processor directly, the PLL is disabled, and the bus mode is set for 1:1 mode operation. This mode is intended for factory use only.
Note: The AC timing specifications given in this document do not apply in PLL-bypass mode.
- In clock-off mode, no clocking occurs inside the 603e regardless of the SYSCLK input.

1.8.2 PLL Power Supply Filtering

The AVdd power signal is provided on the 603e to provide power to the clock generation phase-locked loop. To ensure stability of the internal clock, the power supplied to the AVdd input signal should be filtered using a circuit similar to the one shown in Figure 11. The circuit should be placed as close as possible to the AVdd pin to ensure it filters out as much noise as possible. The 0.1 μF capacitor should be closest to the AVdd pin, followed by the 10 μF capacitor, and finally the 10 Ω resistor to Vdd. These traces should be kept short and direct.

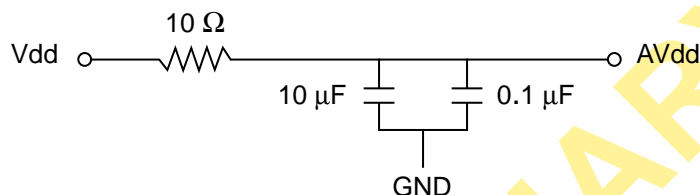

Figure 11. PLL Power Supply Filter Circuit

1.8.3 Decoupling Recommendations

Due to the 603e's dynamic power management feature, large address and data buses, and high operating frequencies, the 603e can generate transient power surges and high frequency noise in its power supply, especially while driving large capacitive loads. This noise must be prevented from reaching other components in the 603e system, and the 603e itself requires a clean, tightly regulated source of power. Therefore, it is recommended that the system designer place at least one decoupling capacitor at each Vdd and OVdd pin of the 603e. It is also recommended that these decoupling capacitors receive their power from separate Vdd, OVdd, and GND power planes in the PCB, utilizing short traces to minimize inductance.

These capacitors should vary in value from 220 pF to 10 μF to provide both high- and low-frequency filtering, and should be placed as close as possible to their associated Vdd or OVdd pin. Suggested values for the Vdd pins—220 pF (ceramic), 0.01 μF (ceramic), and 0.1 μF (ceramic). Suggested values for the OVdd pins—0.01 μF (ceramic), 0.1 μF (ceramic), and 10 μF (tantalum). Only SMT (surface mount technology) capacitors should be used to minimize lead inductance.

In addition, it is recommended that there be several bulk storage capacitors distributed around the PCB, feeding the Vdd and OVdd planes, to enable quick recharging of the smaller chip capacitors. These bulk capacitors should also have a low ESR (equivalent series resistance) rating to ensure the quick response time necessary. They should also be connected to the power and ground planes through two vias to minimize inductance. Suggested bulk capacitors—100 μF (AVX TPS tantalum) or 330 μF (AVX TPS tantalum).

1.8.4 Connection Recommendations

To ensure reliable operation, it is highly recommended to connect unused inputs to an appropriate signal level. Unused active low inputs should be tied to Vdd. Unused active high inputs should be connected to GND. All NC (no-connect) signals must remain unconnected.

Power and ground connections must be made to all external Vdd, OVdd, and GND pins of the 603e.

1.8.5 Pull-up Resistor Requirements

The 603e requires high-resistive (weak: 10 K Ω) pull-up resistors on several control signals of the bus interface to maintain the control signals in the negated state after they have been actively negated and released by the 603e or other bus master. These signals are— $\overline{\text{TS}}$, $\overline{\text{ABB}}$, $\overline{\text{DBB}}$, and $\overline{\text{ARTRY}}$.

In addition, the 603e has three open-drain style outputs that require pull-up resistors (weak or stronger: 4.7 K Ω –10 K Ω) if they are used by the system. These signals are—APE, DPE, and CKSTP_OUT.

During inactive periods on the bus, the address and transfer attributes on the bus are not driven by any master and may float in the high-impedance state for relatively long periods of time. Since the 603e must continually monitor these signals for snooping, this float condition may cause excessive power draw by the input receivers on the 603e. It is recommended that these signals be pulled up through weak (10 K Ω) pull-up resistors or restored in some manner by the system. The snooped address and transfer attribute inputs are—A[0–31], AP[0–3], TT[0–4], $\overline{\text{TBST}}$, and $\overline{\text{GBL}}$.

The data bus input receivers are normally turned off when no read operation is in progress and do not require pull-up resistors on the data bus.

1.8.6 Thermal Management Information

This section provides thermal management information for the ceramic ball grid array (CBGA) package for air-cooled applications. Proper thermal control design is primarily dependent upon the system-level design—the heat sink, airflow and thermal interface material. To reduce the die-junction temperature, heat sinks may be attached to the package by several methods—adhesive, spring clip to holes in the printed-circuit board or package, and mounting clip and screw assembly (CBGA package); see Figure 12. This spring force should not exceed 5.5 pounds of force.

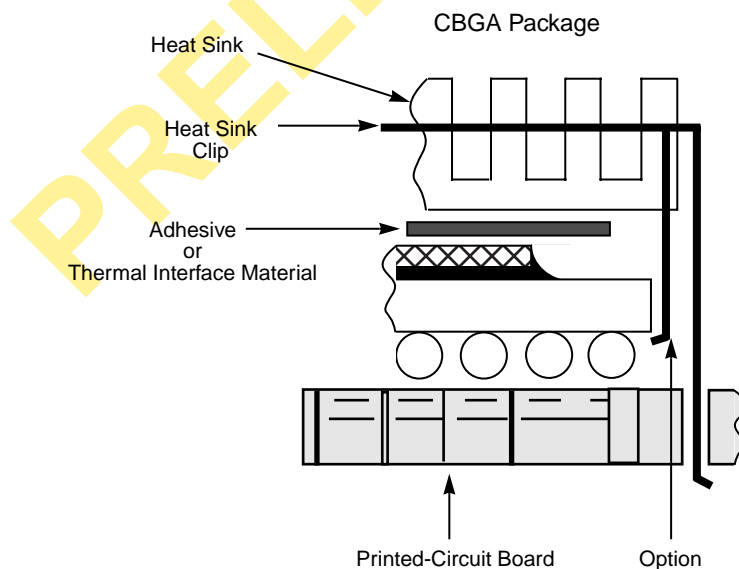

Figure 12. Package Exploded Cross-Sectional View with Several Heat Sink Options

The board designer can choose between several types of heat sinks to place on the 603e. There are several commercially-available heat sinks for the 603e provided by the following vendors:

Chip Coolers Inc. 333 Strawberry Field Rd. Warwick, RI 02887-6979	800-227-0254 (USA/Canada) 401-739-7600
International Electronic Research Corporation (IERC) 135 W. Magnolia Blvd. Burbank, CA 91502	818-842-7277
Thermalloy 2021 W. Valley View Lane P.O. Box 810839 Dallas, TX 75731	214-243-4321
Wakefield Engineering 60 Audubon Rd. Wakefield, MA 01880	617-245-5900
Aavid Engineering One Kool Path Laconia, NH 03247-0440	603-528-3400

Ultimately, the final selection of an appropriate heat sink depends on many factors, such as thermal performance at a given air velocity, spatial volume, mass, attachment method, assembly, and cost.

1.8.6.1 Internal Package Conduction Resistance

For this packaging technology the intrinsic thermal conduction resistance (shown in Table 3) versus the external thermal resistance paths are shown in Figure 13 for a package with an attached heat sink mounted to a printed-circuit board.

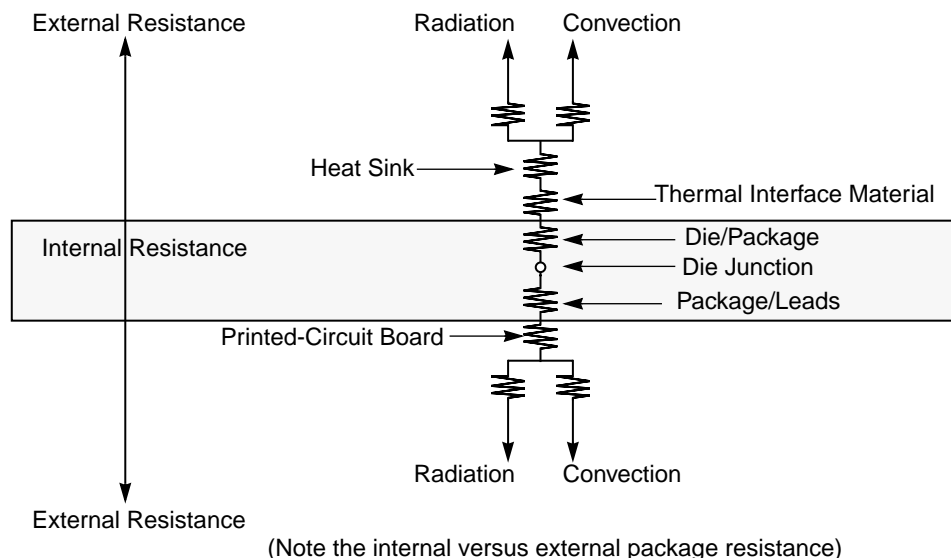

Figure 13. Package with Heat Sink Mounted to a Printed-Circuit Board

1.8.6.2 Adhesives and Thermal Interface Materials

A thermal interface material is recommended at the package lid-to-heat sink interface to minimize the thermal contact resistance. For those applications where the heat sink is attached by spring clip mechanism, Figure 14 shows the thermal performance of three thin-sheet thermal-interface materials (silicone, graphite/oil, floeroether oil), a bare joint, and a joint with thermal grease as a function of contact pressure. As shown, the performance of these thermal interface materials improves with increasing contact pressure. The use of thermal grease significantly reduces the interface thermal resistance. That is, the bare joint results in a thermal resistance approximately 7 times greater than the thermal grease joint.

Heat sinks are attached to the package by means of a spring clip to holes in the printed-circuit board (see Figure 12). This spring force should not exceed 5.5 pounds of force. Therefore, the synthetic grease offers the best thermal performance, considering the low interface pressure. Of course, the selection of any thermal interface material depends on many factors—thermal performance requirements, manufacturability, service temperature, dielectric properties, cost, etc.

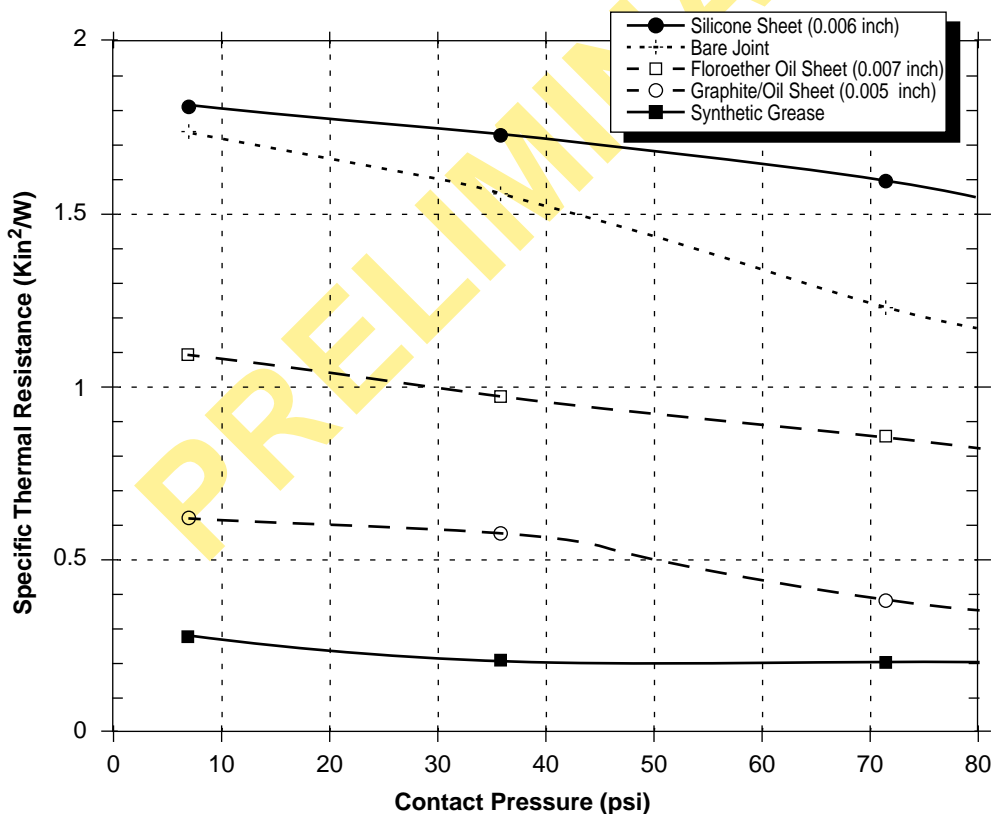

Figure 14. Thermal Performance of Select Thermal Interface Material

The board designer can choose between several types of thermal interface. Heat sink adhesive materials should be selected based upon high conductivity, yet adequate mechanical strength to meet equipment shock/vibration requirements. There are several commercially-available thermal interfaces and adhesive materials provided by the following vendors:

Dow-Corning Corporation Dow-Corning Electronic Materials PO Box 0997 Midland, MI 48686-0997	517-496-4000
Chomerics, Inc. 77 Dragon Court Woburn, MA 01888-4850	617-935-4850
Thermagon Inc. 3256 West 25th Street Cleveland, OH 44109-1668	216-741-7659
Loctite Corporation 1001 Trout Brook Crossing Rocky Hill, CT 06067	860-571-5100
AI Technology (e.g. EG7655) 1425 Lower Ferry Rd Trent, NJ 08618	609-882-2332

The following section provides a heat sink selection example using one of the commercially available heat sinks.

1.8.6.3 Heat Sink Selection Example

For preliminary heat sink sizing, the die-junction temperature can be expressed as follows:

$$T_j = T_a + T_r + (\theta_{jc} + \theta_{int} + \theta_{sa}) * P_d$$

Where:

- T_j is the die-junction temperature
- T_a is the inlet cabinet ambient temperature
- T_r is the air temperature rise within the computer cabinet
- θ_{jc} is the die junction-to-case thermal resistance
- θ_{int} is the adhesive or interface material thermal resistance
- θ_{sa} is the heat sink base-to-ambient thermal resistance
- P_d is the power dissipated by the device

During operation the die-junction temperatures (T_j) should be maintained less than the value specified in Table 2. The temperature of the air cooling the component greatly depends upon the ambient inlet air temperature and the air temperature rise within the electronic cabinet. An electronic cabinet inlet-air temperature (T_a) may range from 30 to 40 °C. The air temperature rise within a cabinet (T_r) may be in the range of 5 to 10 °C. The thermal resistance of the thermal interface material (θ_{int}) is typically about 1 °C/W. Assuming a T_a of 30 °C, a T_r of 5 °C a CBGA package $\theta_{jc} = 0.095$, and a power consumption (P_d) of 3.0 Watts, the following expression for T_j is obtained:

$$\text{Die-junction temperature: } T_j = 30 \text{ °C} + 5 \text{ °C} + (0.095 \text{ °C/W} + 1.0 \text{ °C/W} + R_{sa}) * 3.0 \text{ W}$$

For a Thermalloy heat sink #2328B, the heat sink-to-ambient thermal resistance (R_{sa}) versus airflow velocity is shown in Figure 15.

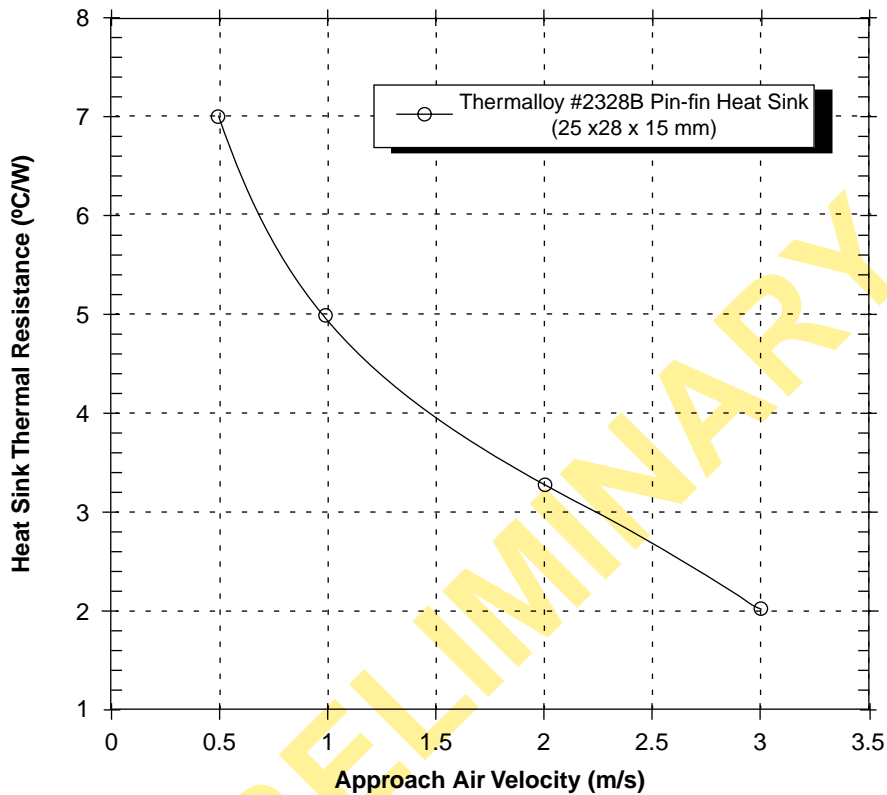

Figure 15. Thermalloy #2328B Heat Sink-to-Ambient Thermal Resistance Versus Airflow Velocity

Assuming an air velocity of 0.5 m/s, we have an effective R_{sa} of 7 °C/W, thus

$$T_j = 30^\circ\text{C} + 5^\circ\text{C} + (0.095^\circ\text{C/W} + 1.0^\circ\text{C/W} + 7^\circ\text{C/W}) * 3.0 \text{ W},$$

resulting in a die-junction temperature of approximately 60 °C which is well within the maximum operating temperature of the component.

Other heat sinks offered by Chip Coolers, IERC, Thermalloy, Wakefield Engineering, and Aavid Engineering offer different heat sink-to-ambient thermal resistances, and may or may not need air flow.

Though the die junction-to-ambient and the heat sink-to-ambient thermal resistances are a common figure-of-merit used for comparing the thermal performance of various microelectronic packaging technologies, one should exercise caution when only using this metric in determining thermal management because no single parameter can adequately describe three-dimensional heat flow. The final die-junction operating temperature, is not only a function of the component-level thermal resistance, but the system-level design and its operating conditions. In addition to the component's power consumption, a number of factors affect the final operating die-junction temperature—airflow, board population (local heat flux of adjacent components), heat sink efficiency, heat sink attach, heat sink placement, next-level interconnect technology, system air temperature rise, altitude, etc.

Due to the complexity and the many variations of system-level boundary conditions for today's microelectronic equipment, the combined effects of the heat transfer mechanisms (radiation, convection and conduction) may vary widely. For these reasons, we recommend using conjugate heat transfer models for the board, as well as, system-level designs. To expedite system-level thermal analysis, several “compact” thermal-package models are available within FLOTHERM®. These are available upon request.

1.9 Ordering Information

Figure 16 provides the part numbering nomenclature for the PID7t-603e. Note that the individual part numbers correspond to a maximum processor core frequency. For available frequencies, contact your local Motorola sales office.

In addition to the processor frequency, the part numbering scheme also consists of a part modifier and application modifier. The part modifier indicates any enhancement(s) in the part from the original design. The application modifier may specify special bus frequencies or application conditions. Each part number also contains a revision code. This refers to the die mask revision number and is specified in the part numbering scheme for identification purposes only.

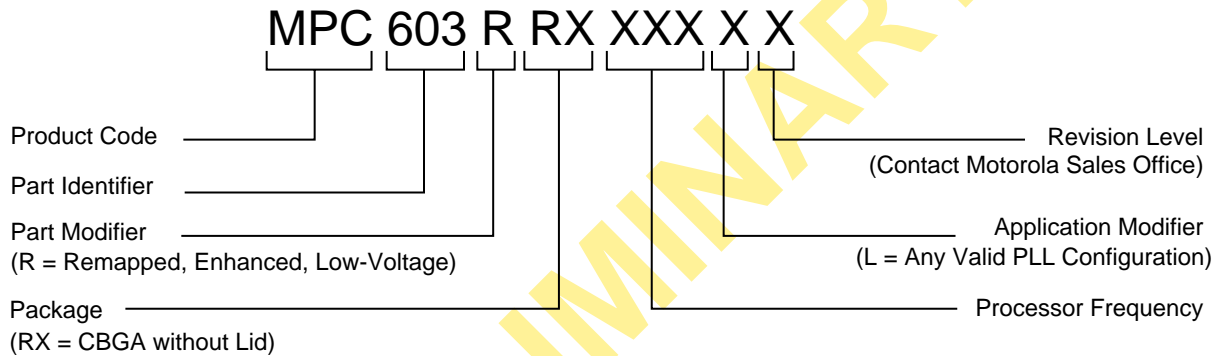



Figure 16. Part Number Key

Information in this document is provided solely to enable system and software implementers to use PowerPC microprocessors. There are no express or implied copyright licenses granted hereunder to design or fabricate PowerPC integrated circuits or integrated circuits based on the information in this document.

Motorola reserves the right to make changes without further notice to any products herein. Motorola makes no warranty, representation or guarantee regarding the suitability of its products for any particular purpose, nor does Motorola assume any liability arising out of the application or use of any product or circuit, and specifically disclaims any and all liability, including without limitation consequential or incidental damages. "Typical" parameters can and do vary in different applications. All operating parameters, including "Typicals" must be validated for each customer application by customer's technical experts. Motorola does not convey any license under its patent rights nor the rights of others. Motorola products are not designed, intended, or authorized for use as components in systems intended for surgical implant into the body, or other applications intended to support or sustain life, or for any other application in which the failure of the Motorola product could create a situation where personal injury or death may occur. Should Buyer purchase or use Motorola products for any such unintended or unauthorized application, Buyer shall indemnify and hold Motorola and its officers, employees, subsidiaries, affiliates, and distributors harmless against all claims, costs, damages, and expenses, and reasonable attorney fees arising out of, directly or indirectly, any claim of personal injury or death associated with such unintended or unauthorized use, even if such claim alleges that Motorola was negligent regarding the design or manufacture of the part.

Motorola and  are registered trademarks of Motorola, Inc. Mfax is a trademark of Motorola, Inc. Motorola, Inc. is an Equal Opportunity/Affirmative Action Employer.

IBM is a trademark of International Business Machines Corporation.

The PowerPC name, the PowerPC logotype, and PowerPC 603e are trademarks of International Business Machines Corporation used by Motorola under license from International Business Machines Corporation.

Motorola Literature Distribution Centers:

USA/EUROPE: Motorola Literature Distribution; P.O. Box 5405; Denver, Colorado 80217; Tel.: 1-800-441-2447 or (303) 675-2140

JAPAN: Nippon Motorola Ltd SPD, Strategic Planning Office 4-32-1, Nishi-Gotanda Shinagawa-ku, Tokyo 141, Japan; Tel.: 81-3-5487-8488

ASIA/PACIFIC: Motorola Semiconductors H.K. Ltd.; 8B Tai Ping Industrial Park, 51 Ting Kok Road, Tai Po, N.T., Hong Kong; Tel.: 852-26629298

Mfax™: RMFAX0@email.sps.mot.com; TOUCHTONE (602) 244-6609; US & Canada ONLY (800) 774-1848

INTERNET: <http://www.mot.com/SPS/>

Technical Information: Motorola Inc. SPS Customer Support Center; (800) 521-6274.

Document Comments: FAX (512) 891-2638, Attn: RISC Applications Engineering.

World Wide Web Address: <http://www.mot.com/powerpc/>

MPC603E7TEC/D

