

ISSUE

71

COMPUTIST

U.S. \$3.75

Canada & Mexico \$7

News for Speed Demons  
The 8Mhz Zip Chip is shipping  
Send for yours today!  
\$157 plus \$2 postage

The COMPUTIST BBS is On-line  
at (206) 581-9292

COMPUTIST is Moving to:  
33821 E Orville Rd.  
Eatonville, WA 98328

# Subscribe to COMPUTIST We give you More!

Only \$24 for your first 8 issues

- I am
- A new subscriber
  - Renewing my current subscription
  - Changing my address (Please include last mail label)

- Subscription rates
- U.S. (bulk) ..... \$24
  - U.S. First Class / Canada / Mexico ..... \$34
  - All other Foreign ..... \$54

Name \_\_\_\_\_ ID# \_\_\_\_\_

Address \_\_\_\_\_

City \_\_\_\_\_ State \_\_\_\_\_ Zip \_\_\_\_\_

Country \_\_\_\_\_ Phone \_\_\_\_\_

Visa  MC \_\_\_\_\_ Exp. \_\_\_\_\_

Signature \_\_\_\_\_ CP71

•Send US funds drawn on US bank. • Please allow 4-8 weeks for 1st issue or add \$1.25 for postage and we will send your 1st issue by 1st Class mail. • Send check/money order to:

COMPUTIST 33821 E Orville Rd Eatonville WA 98328 (206) 474-5750

COMPUTIST  
33821 E Orville Rd  
Eatonville WA 98328

BULK RATE  
U.S Postage  
**PAID**  
Tacoma WA  
Permit No. 269

# COMPUTIST

Charles R. Haight Editor  
Tom Acree Associate Editor  
Karen Fitzpatrick Circulation  
Jeff Hurlburt Reviews

COMPUTIST is published by SoftKey Publishing. Address all advertising inquiries to:

COMPUTIST  
Advertising Department  
33821 East Orville Road  
Eatonville, WA 98328  
(206) 474-5750

Mail all RDEX letters to:

COMPUTIST  
Apple-RDEX or IBM-RDEX  
33821 East Orville Road  
Eatonville, WA 98328

• COMPUTIST does NOT purchase editorial material. The entire editorial content consists of information submitted to COMPUTIST for publication in the shared interests of all COMPUTISTS.

• Unsolicited material (manuscripts, letters to the editor, softkeys, A.P.T.s, playing tips, questions, etc.) are assumed to be submitted as letters-to-the-RDEX-editor for publication with all and exclusive rights belonging to COMPUTIST.

• Entire contents copyright 1989 by SoftKey Publishing. All rights reserved. Copying done for other than personal or internal reference (without express written permission from the publisher) is prohibited.

• The editorial staff assume no liability or responsibility for the products advertised in this newsletter. Any opinions expressed by the authors are not necessarily those of COMPUTIST magazine, its staff or SoftKey Publishing.

**SUBSCRIPTIONS:** Rates (for 8 issues):

U.S. ....\$24 Canada/Mexico .....\$34  
U.S. 1st Class .....\$34 Other Foreign .....\$54

• Send subscription inquiries to:

COMPUTIST  
Subscription Department  
33821 East Orville Road  
Eatonville, WA 98328

• Domestic Dealer rates: Call (206) 474-5750 for more information.

• Change Of Address: Please allow 4 weeks for change of address to take effect. On postal form 3576 supply your new address and your most recent address label. When we receive your notice of change of address, we will send you a acknowledgement card. If you do not receive the acknowledgement card after 2 weeks, send another notice or call us direct.

*Issues missed due to non-receipt of change of address may be acquired at the regular back issue rate.*

*We are not responsible for missing issues 90 days after mailing date. If you do not receive an issue at the usual time each month, please call or write.*

Apple® is a trademark of Apple Computers. IBM® is the IBM trademark.

## Readers Data EXchange

New COMPUTIST readers using Apple IIs are advised to read this page carefully to avoid frustration when attempting to follow a softkey or entering the programs printed in this issue.

### What is a softkey, anyway?

Softkey is a term which we coined to describe a procedure that removes, or at least circumvents, any copy-protection on a particular disk. Once a softkey procedure has been performed, the resulting backup copy can usually be copied by the normal copy programs (for example: COPYA, on the DOS 3.3 System Master disk).

### Commands and control keys

Commands which a reader is required to perform are set apart by being in boldface and on a separate line. The return key must be pressed at the end of every such command unless otherwise specified. Control characters are preceded by "ctrl". An example of both is:

**6 ctrl P**

Type 6. Next, place one finger on the ctrl key and then press P. Don't forget to press the return key.

Other special combination keypresses include **ctrl reset** and **open-apple ctrl reset**. In the former, press and hold down the ctrl key then press the reset key. In the latter, press and hold down both ctrl and open-apple then press reset.

### Software recommendations

The Starter Kit contains most of the programs

that you need to "Get started". In addition, we recommend that you acquire the following:

- Applesoft program editor such as "Global Program Line Editor (GPLE)".
- Assembler such as "Merlin/Big Mac".
- Bit-copy program such as "Copy II Plus", "Locksmith" or "Essential Data Duplicator".
- Word-processor (such as AppleWorks).
- "COPYA", "FID" and "MUFFIN" from the DOS 3.3 System Master disk.

### Super IOB and Controllers

This powerful deprotection utility (in the COMPUTIST Starter Kit) and its various Controllers are used in many softkeys. (It is also on each Super IOB Collection disk.)

### Reset into the Monitor

Softkeys occasionally require the user to stop the execution of a copy-protected program and directly enter the Apple's system monitor. Check the following list to see what hardware you will need to obtain this ability.

Laser 128: Your ROM includes a forced jump to the monitor. Press **ctrl return reset**.

Apple II+, //e, compatibles: 1) Place an Integer BASIC ROM card in one of the Apple slots. 2) Use a non-maskable interrupt (NMI) card such as Replay or Wildcard.

Apple II+, compatibles: 1) Install an F8 ROM with a modified reset-vector on the computer's motherboard as detailed in the "Modified ROM's" article (COMPUTIST #6 or Book Of Softkeys III) or the "Dual ROM's" article (COMPUTIST #19).

Apple //e, //c: Install a modified CD ROM on the computer's motherboard that changes the open-apple ctrl reset vector to point to the monitor. (This will void an Apple //c warranty since you must open the case to install it.)

Apple //gs: If you have the 2.x ROM, there is a hidden classic desk accessory (CDA) that allows you to enter the monitor. In order to install the new CDA, you should enter the monitor (CALL -151) before running any protected programs and press # return. This will turn on two hidden CDAs, Memory Peeker and Visit Monitor. Thereafter press open-apple ctrl esc to go to the Desk Accessories menu. Select Visit Monitor and there you are. Use ctrl Y to exit.

### Recommended literature

- Apple II Reference Manual (or IIe, IIc, etc.)
- DOS 3.3 or ProDOS manual
- Beneath Apple DOS & Beneath Apple ProDOS, by Don Worth and Pieter Lechner, from Quality Software

### Typing Applesoft programs

BASIC programs are printed in a format that is designed to minimize errors for readers who key in these programs. If you type:

```
10HOME:REMCLEAR SCREEN
```

The LIST will look like:

```
10 HOME : REM CLEAR SCREEN
```

Applesoft inserts spaces into a program listing before and after every command word or mathematical operator. These spaces don't pose a problem except when they are inside of quotes or after a DATA command. There are two types of spaces: those that have to be keyed and those that don't. Spaces that must be typed appear in COMPUTIST as special characters (◊). All other spaces are there for easier reading.

NOTE: If you want your checksums to match, only type spaces within quotes or after DATA statements if they are shown as (◊) characters. SAVE the program at periodic intervals using the name given in the article. All characters after a REM are not checked by the checksum program so typing them is optional.

### Typing Hexdumps

Machine language programs are printed in COMPUTIST as hexdumps, sometimes also as source code.

Hexdumps are the shortest and easiest format to type in. You must first enter the monitor:  
**CALL -151**

Key in the hexdump exactly as it appears in the magazine, ignoring the four-digit checksum (\$ and four digits) at the end of each line. When finished, return to BASIC with:  
**3D0G**

BSAVE the program with the filename, address and length parameters given in the article.

### Typing Source Code

The source code is printed to help explain a program's operation. To enter it, you need an "Assembler". Most of the source code in older issues is in S-C Assembler format. If you use a different assembler, you will have to translate portions of the source code into something your assembler will understand.

### Computing checksums

Checksums are 4-digit hexadecimal numbers which tell if you typed a program correctly and help you locate any errors. There are two types of checksums: one created by the CHECKBIN program (for machine language programs) and the other created by the CHECKSOFT program (for BASIC programs). Both are on the "Starter Kit".

If your checksums do not match the published checksums then the line where the first checksum differs is incorrect.

CHECKSOFT instructions: Install Checksoft (BRUN CHECKSOFT) then LOAD your program. Press & to get the checksums. Correct the program line where the checksums first differ.

CHECKBIN instructions: Enter the monitor (CALL -151), install Checkbin at some out of the way place (BRUN CHECKBIN, A\$6000), and then LOAD your program. Get the checksums by typing the Starting address, a period and the Ending address of the file followed by a ctrl Y.

**SSSS.EEEE ctrl Y**

Correct the lines where the checksums differ.

### Writing to the RDEX editor

RDEX (are-decks) stands for: Reader's Data EXchange. We print what you write. When you send in articles, softkeys, APTs, etc., you are submitting them for free publication in this magazine. RDEX does not purchase submissions nor do we verify data submitted by readers. If you discover any errors, please let us know so that we may inform our other readers.

Remember that your letters or parts of them may be used in RDEX even if not addressed to the RDEX editor. Correspondence that gets published may be edited for clarity, grammar and space requirements.

Because of the great number of letters we receive and the ephemeral and unpredictable appearance of our volunteer staff, any response to your queries will appear only in RDEX, so it would be more appropriate for you to present technical questions to the readers and ask for their responses which will then be placed in the Apple-RDEX.

### How to get a free library disk

Whenever possible, send everything on Apple format (5.25" - DOS/ProDOS or 3.5" - ProDOS) or IBM format (3.5") disks. Other formats are acceptable but there may be some delay as we look for someone to translate it for us. (If you use a 5.25" disk, when we print your letter, we will return your disk with the current library disk copied onto it.) Use whatever text editor you like, but tell us which one. Put a label on the disk with your name (or pseudonym) and address (if you want to receive mail). Don't reformat any programs or include them in the text of your letter. Send Applesoft programs as normal Applesoft files and machine language programs as normal binary files. We have programs to con-

vert them to the proper format for printing. If you are sending source code files, and you are not using the S-C Assembler, send them as normal text files.

### When to include a printed letter

Don't include hardcopy (printout) unless:

- a. You are writing about a bug or other printing error.
- b. You are writing to ask for help.
- c. You are answering another readers help request.
- d. You are writing about your subscription or sending an order for back issues or software.

Bugs, requests for help and answers to requests for help are bumped to the head of the line and go in the very next issue. All other letters are printed in the order that we receive them.

### Writing to get help

When writing to request help, be sure to include ALL relevant information. The more information you include, the easier it is to find a solution. There's an old saying that goes "A properly framed question includes 90% of the answer".

### How to get mail

If you are interested in receiving mail from other readers, be sure that we have a current address. If you use a pen name and want to receive mail, we need to have your address. Our readers privacy is important, so we will not print your address unless you specifically say too.

### How to write to RDEX authors

When writing to one of the RDEX authors. Write your letter and seal it in an envelope. Put your return address, the authors name (as it appears in RDEX) and the correct postage on the envelope. Put this envelope into another and send it to RDEX. We will put the correct address on your letter and mail it for you.

### Help Line

These readers have volunteered their time to help you. Please call only within the given time frames (corrected for your time zone). No collect calls.

Jack Nissel (Disk Protection, 7-10PM EST)  
(215) 365-2905

### Electronic Bulletin Board System (BBS)

Dave Goforth is the sysop for the Computist BBS. The number is: (206) 581-9292. If you already have a User ID# and password, sign-on using the User ID#. If you are a new user, it may take a day or so to validate your new ID# and password.

## You have a LEGAL RIGHT to an unlocked backup copy of your commercial software.

*Our editorial policy is that we do NOT condone software piracy, but we do believe that users are entitled to backup commercial disks they have purchased.*

*In addition to the security of a backup disk, the removal of copy-protection gives the user the option of modifying programs to meet his or her needs.*

*Furthermore, the copyright laws guarantee your right to such a DEPROTECTED backup copy:*

... "It is not an infringement for the owner of a copy of a computer program to make or authorize the making of another copy or adaptation of that computer program provided:

- 1) that such a new copy or adaptation is created as an essential step in the utilization of the computer program in conjunction with a machine and that it is used in no other manner, or
- 2) that such new copy or adaptation is for archival purposes only and that all archival copies are destroyed in the event that continued possession of the computer program should cease to be rightful.

Any exact copies prepared in accordance with the provisions of this section may be leased, sold, or otherwise transferred, along with the copy from which such copies were prepared, only as part of the lease, sale, or other transfer of all rights in the program. Adaptations so prepared may be transferred only with the authorization of the copyright owner."

United States Code title 17, §117

# ISSUE 71

# COMPUTIST

U.S. \$3.75

Canada & Mexico \$7

## Table of Contents

Editorial .....	4
The Product Monitor .....	5
RDEX Contributors .....	23
Most Wanted Softkeys .....	23

### Softkeys:

4th & Inches: Team Construction Disk .....	8
2400 AD .....	17
A Science Experiment .....	13
An Introduction to General Chemistry .....	21
Analogies - Advanced I & Advanced II .....	20
Antonyms & Sentence Completion (Best Sentences) .....	20
Award Maker Plus .....	13
Battle Chess .....	7
Body in Focus .....	13
Boppie's Great Word Chase .....	12
Botanical Gardens .....	13
Bubble Ghost .....	7
California Games GS .....	13
California Games GS .....	19
Campaign Math .....	12
Case of the Great Train Robbery .....	15

### Features, Notes and such:

A BUG in Copy II Plus ver 9.0 .....	11
A Reader Review of the Trac Card .....	21
Deprotecting MircoLab Disks .....	18
Enhancements to APT Scanner .....	14
Locksmith 6.0 Fastcopy with E.A. RWTS (Revised) .....	16
Putting Bubble Ghost in Harddisk .....	7
Super IOB Block Patch .....	15
The Computist BBS .....	4
The Junior PROM .....	14
The Mandelbrot Set .....	17
The Product Monitor .....	5

Case of the Missing Chick .....	15	Sports Stats .....	17
Cavern Creatures .....	6	Starglider .....	20
ChessMaster 2100 .....	7	Stickybear Talking Opposites .....	11
Children's Writing & Publishing Center ....	8, 20	Story Tree .....	13
Comment Dit-On? .....	17	Superprint v1.2 .....	12
Computer Inspector v1.0 .....	17	Superstar Ice Hockey .....	11
Congo .....	6	Surveys Unlimited .....	12
Crosscountry Canada .....	16	Tag Team Wrestling .....	6, 13
Crystal Quest .....	7	Ten Clues .....	13
Cutthroat .....	6	The Duel: Test Drive II .....	11
Deja-Vu .....	7	Tip 'N Flip .....	13
Deja-Vu II .....	7	Uninvited .....	7
Dinosaur Days .....	14	VCR Companion .....	13
FastBreak .....	7	Where in the World is Carmen San Diego GS v1.0 .....	11
Final Assault .....	8	Word Puzzles for Creative Teaching .....	20
French: Verb Pairs and Idioms .....	17	World Geography v1.0 .....	11
Geometry v1.0 .....	9	Xenocide .....	11
Gnee or Not Gnee .....	13		
High Wire Logic .....	13		
Impossible Mission II GS .....	6, 9		
Into the Eagles Nest .....	6		
Jack Nicklaus' 18 Holes of Major Championship Golf .....	9		
Jigsaw .....	18		
Jump Jet .....	6		
Kinderama .....	9		
King of Chicago .....	6		
LA Crackdown .....	6		
Magic Slate v1.3 .....	17		
Magic Spells .....	12		
Math Blaster Mystery .....	19		
Math Blaster Plus .....	9		
Microcomputer Study Guide - Fundamental Accounting Principles Chapters 1-14 & 15-28 .....	20		
Ming's Challenge .....	18		
Mission Escape .....	6		
Monsters and Make Believe .....	20		
Multiscribe v3.0 .....	20		
Mystery of the Witches Shoes .....	15		
Organic Chemistry .....	21		
Qix .....	9		
Reading Professor .....	20		
Renegade .....	10		
Science 4: Understanding our Solar System .....	15		
Shadowgate .....	7		
Sign Designer .....	13		
Slipheed .....	10		
Soko Ban .....	5		
Sporting News Baseball .....	10		

### Bitkeys:

Game Show .....	17
Magic Spells .....	15
Story Tree .....	15

### APTs:

APTs	
2400 AD .....	16
Microwave .....	14
Oil's Well .....	14
Qix .....	10
Trolls and Tribulations .....	14
Xenocide .....	11

### Playing Tips:

Leisure Suit Larry .....	18
Might & Magic II .....	6

### IBM Softkeys:

Zany Golf .....	22
-----------------	----

### IBM Playing Tips:

Manhunter .....	22
Rocket Ranger .....	22

### IBM APTs:

Wizardry V .....	22
Zany Golf .....	22

**Zip Chip vs Rocket Chip**

It seems that Rocket chips are going to become a little scarce. The word we received is that Zip Technology won the lawsuit against Bits and Pieces Technology (BPT) and that BPT cannot manufacture any more speedup chips.

While the Rocket chip is deceased, the 8Mhz Zip Chip is shipping (we've already sent out a few) and we can send you one for \$157 plus \$2 for UPS (or \$4 for Second Day Air, if you're in a hurry). Pricing is pretty predatory so you may be able to find a lower price from one of the mail order houses. Let us know if you do.

**New Address**

Computist is moving its offices to Eatonville (where I live). No more 60 mile round trips to Tacoma whenever work needs to be done on the magazine! That means I can work on Computist stuff in the evenings and be able to spend a little more time working (and a lot less time commuting).

**Tighter format, more data**

Back to the compressed format. So many of the letters that I've received say it's OK, that I'm trying it out. It's harder than it looks to use 4-columns per page, especially when there is a lot of source code. Text is easy, of course, since it is handled automatically by the page layout program. But commented code is too wide and when it wraps around, it's not very readable. That means extra editing must be done, which takes a lot of time. Also, some of your letters, have column type data that is formatted for 80 columns. That involves more time to convert to a narrow 4-column format. (Although, if it has to be in a wide multi-column format, I can put it in a box that spans several columns.) So, when you write to us, keep in mind the narrow columns. I really appreciate it.

Anyway, I'm getting used to this MAC and Pagemaker and it's getting easier to get each issue out each month. Our lateness on this issue is because of some extra time it took to work out the bugs in the 4-column format along with some minor problems with the mailing.

**A Book for issue 66**

Speaking of formats, I've come up with a two column format for the Book. I'm trying it out with Computist #66 (the one that we are out of). The 34 tabloid size pages of text in #66 converts to about 65 pages in an 8 1/2 by 11 size book format. Anyone who orders issue #66, at regular back issue prices, will receive the book formatted pages. They're setup for 3 hole punch to fit in a three ring binder.

**The COMPUTIST BBS  
(206) 581-9292**

The BBS is ready, but it's in the seedling stage and is going to require some careful nurturing. We don't have a clock card yet and we're wondering if anyone out there has an extra one that they could loan us (on a long term basis). Or, maybe we could trade for back issues or library disks.

Everyone who joined the Club should find a slip of paper in their issue. (I suggest you look for it, right now!!!) If you do not find the slip of paper and you have paid your club fee, contact us immediately. The paper is marked with two numbers and a word or phrase. The first number is your club number and should match the number on your label. If it doesn't, contact us immediately. The second number is your BBS user ID number. You should use this number when you sign-on to the BBS. The word or phrase is your initial password. After you sign-on, you may change your password to whatever you wish. We got the initial passwords by writing a program that randomly pulled words from a thesaurus program. So if your password is something weird, you know why. You wouldn't believe some of the words and phrases that came out of that thesaurus.

**Hardware Happenings**

The verdict's in on the Display card. Guilty of dullness and lack of interest. Out of about 4000 subscribers, only 15 were interested in assembling the card.

Here's why that isn't enough orders. The setup fee for manufacturing an average size card is between \$200-300. Then, the actual card costs between \$10 and \$20 each. Since these are very small cards, the real cost is \$7.60 for one and \$6.90 for the other, or \$15 for both.

If we share the setup fee, (300/15 = 20) that would mean that the cost to each of us would be \$20. Now add the \$15 for the 2 card set and \$15 for the components and we have a grand total of \$50.

That's pretty steep for a card that is essentially a toy. (And an unassembled toy, at that!)

So we returned the checks and didn't order any Display cards. The board layouts, parts lists and net lists are available for anyone who wants to make the card on their own. Send a letter to Karen, along with a dollar for postage. If you do make the boards yourself, consider making a couple extra and selling them to other interested readers. Or maybe someone knows where we can get the boards done for less?

Now the question is, "What do we do with the other projects?" We have two other projects that are at the board stage and a dozen more in various stages of progress.

The first project is a special memory card that holds 8 - 32K SRAMs (Static RAM) for a total of 256K of RAM. The card looks like a 256K disk drive, a very fast disk drive. A special Integrated Circuit (IC) from Maxim maintains the voltage to the SRAMs when you turn off your computer. It also detects a power failure and locks out writes to the card to protect the memory. You can save data to the card (just like to a disk) and turn off your computer. Then, in the morning, when you're ready to start computing, the data would still be there. I use the prototype to hold DOS 3.3, ProDOS 8 and my most often used utility programs, so I can switch between them in a fraction of a second. I have the card plugged into slot 7, so when I first turn on my IIe, DOS is instantly loaded. Naturally, I call it the "Instant On" card. The prototype cost almost \$400 (2 blank cards plus the setup charge). And now that I've had time to play with it, I've thought of some changes that would be nice to make before the board layout is finalized.

\$400 is a bit expensive. You could buy the Stat Disk card from A2 Central for a lot less. But, if we had 50 readers who were interested, the cost would come down some. It would be about \$6 each for the setup fee (300/50 = 6), \$25 per bare card (less if we don't want gold plating on the connector), \$14 for misc. parts (some IC's and sockets), and \$10 per 32K SRAM chip. The total cost of the board (stuffed with 256K of RAM) would be about \$123. That compares favorably with the Stat Disk card with 128K for \$209. (Although, the Stat Disk comes with some valuable software and is expandable beyond 256K.)

The second project is the "Smart" card (for the IIe). This card has its own microprocessor, and it can stop the IIe, and examine and change any location in memory, all without leaving any trace of its activity. The perfect card for the active COMPUTIST. If you are playing a game, you can stop it, at any time, and give yourself some more men or weapons. Hackers can use it to do parallel processing, or program the card to do background sound effects while your main program is running in your IIe, all without the main program knowing what's happening. It also has a programmable break point monitor. That means that you could tell the card to freeze the Apple and come to you whenever a certain address is referenced by the program in memory. Krackers take note, we put the breakpoint monitor in there for you. It makes it real easy to track what a protected program is doing.

Dave Goforth, the COMPUTIST BBS sysop, asked about a RAM card for the IIgs. We'll need some physical measurements of the space around the IIgs RAM expansion slot but it doesn't look too tough. A look at the IIgs Hardware Manual shows that all the signals you need for the first 4 Mbytes are supplied by the expansion slot. I figure about \$100 for the completed board (including gold plated connectors) and \$100 for each 1Meg SIMM. So a 4 Meg RAM board would cost about \$500.

Keep in mind that all of these costs are for unassembled boards, you have to do the soldering and assembly yourself. While soldering is not difficult, you do have to take care and have a steady hand. This also presupposes that enough readers are interested in a certain project to make it possible to order the boards. We're not set up here to become a manufacturing company, and if we did, we would probably have to charge a lot more for each board, just like other companies. They also have to recoup the cost of designing and testing their hardware. I'd rather donate my time and keep this on a one-on-one basis with interested readers so that the costs stay reasonable.

But we don't know if anyone is really interested. Maybe it's just that the first project was uninteresting or was poorly presented or if maybe there's not really enough interest in hardware anymore. Personally, I like designing new hardware. But, this is your newsletter and if you would rather not waste any more space on hardware, then we won't. So, be sure to write and let us know how you feel.

And if you are interested, please tell us what kind of project you want to see. That way, we won't be wasting time working on uninteresting projects. I'll take a look at what you want and tell you if I can design it, and if so, what I think it will cost to build it. Then we can go on from there. Is that a deal?

**David Goforth WA**

Well I'm sorry to hear about those people who said that when their subscription ran out they would not be renewing because:

**The COMPUTIST BBS is here!!!**

Hopefully they know someone else who subscribes and will see just what they will be missing and reconsider. I too had thought as they did and did not like the tabloid format and briefly considered calling it quits, but I knew that I could not find the information that COMPUTIST prints in any other magazine and even sent in my \$10 to

help them out AFTER the tabloid format started. I even helped send out issue #70 (two weeks after I'd received #69) and discovered exactly what they are going through. It's difficult to imagine but I will attempt to describe as a subscriber what I saw.

As Charles Haight has said, they have an all volunteer staff (so they can't cut costs there since there are no paid employees) and I was only one of six people working to get you and nearly 4,000 others their copy of COMPUTIST before Christmas. Second, the only money spent is for the actual printing and mailing costs of the magazine (the fewer the magazines, the more it costs per issue) we even put on all the address labels (which were printed on the computer in the office), sorted, and bundled them. About 8 hours non-stop work for everyone (I know, a days work is not bad but, they usually don't have that many people either). They had about another 2-4 hours work ahead before they would be completely ready to mail (Postal system is very picky) when we quit for the day. Then as I was about to leave we began discussing the upcoming issue (#71) which would have to be finished and ready to mail by the 12th of December and this was November 22nd (day before Thanksgiving!)

So, after seeing the working conditions, where the money goes, and the antiquated equipment being used (II+'s, Franklin ACE 1000's, a few IIe's and one Mac that was on loan from another subscriber) I think that Charles Haight and all the subscribers that have been with them since the early 80's deserve much more credit than we've been giving them. To keep this publication alive and going this long with what they have is incredible. But don't get me wrong, \$32 a year IS outrageous but the ONLY way to reduce the cost of the magazine is to double the number of subscribers which would effectively have the following results:

1. Double the gross income of COMPUTIST while,
2. reducing the cost per issue for printing.

Somewhere, in there, is enough net profit to hire a full time editor (why? because as of Nov, there are letters dating back to June that have not yet been replied to because this volunteer staff have other jobs and families including Mr Haight - NO ONE GETS PAID and time is not something most people have a lot of unless they are getting paid), upgrade some of the equipment they are using AND allow for reducing the cost of the magazine to its subscribers, it may even allow returning to the nice magazine format if that was the preference over reducing the \$32 annual charge. I've found two subscribers by word of mouth in the last month and one about three months ago who liked it so much he bought EVERY back issue from day one thru his current which was around #64 (I couldn't afford that but HE found a way because he believed in what COMPUTIST stands for and didn't want to see it perish, besides he needed a lot of the older softkeys). No one person can do all of it, if each of us can get just two new subscribers or at least talk those considering quitting to continue we may have a real magazine at an affordable cost again... Now on to the BBS!!!

I have been a subscriber to COMPUTIST since issue 15 when I first heard about it while in Okinawa, Japan. I've been watching all the requests for a BBS and after setting up my own BBS (the GOPHER HOLE - (206) 584-3320) in September, modifying the software to suit my needs and to get a feel as to what was involved in running a BBS, I approached Mr Haight as a volunteer for the COMPUTIST BBS. I expected to use my IIgs and add an area for COMPUTIST subscribers to the existing board. He instead decided to have a dedicated system and supplied me with a IIe and all necessary hardware to set thing up and get it going. Well it's up and as of now this is what's available and how it works:

All subscribers who sent in their \$10 (or more) already have full access granted to the system. (See the editorial. ed) Others will have to log on as new users with limited access until validated (usually 1-3 days). The following areas are available:

**Bulletins:** This is where informative information about COMPUTIST and the BBS is listed. Recommend all users read this the first time they log on. The Most Wanted list is also in this section.

**Messages:** Is broken down into three areas:

- 1) RDEX for inputting letters to COMPUTIST and allowing other subscribers to read and answer them possibly even before publication.
- 2) E-MAIL is for sending private letters to other COMPUTIST subscribers.
- 3) CLASSIFIED for placing ads just as you would in a newspaper.

To decrease the amount of time spent on the BBS and long distance rates by the phone company, each message area has the ability to do a 'F'ile transfer. If you have a fairly long article or many small ones and wish to send them as fast as possible, I suggest you do the following: Enter the RDEX message base and leave a short note that you wish to have the attached file published. Then enter a blank line and a menu will appear, press 'F'ile and then send the file using XMODEM protocol. After the transfer is complete then select 'S'ave. I recommend using 'ShrinkIt' or some other type of file compression method

beforehand to make the file as small as possible. This will make the transfer even quicker and will also allow multiple files to be combined in one transfer (NOTE: The 'F'ile command will ONLY allow one file to be attached to each message).

**Files:** Public Domain software library and programs published in COMPUTIST. This area is divided into DOS 3.3, ProDOS, IIgs, and RDEX. The RDEX is for files that you wish to send to COMPUTIST for publication.

**Utilities:** A current User list and Personal data area is here to change your password and other information about yourself. ALL personal data is kept strictly confidential and not made available to other subscribers (except name).

**Help:** There is on-line help for all commands available on the BBS.

The BBS is using Appletalk v2.1c (a modified version of 1.3c by Kevin D'Hayse). It supports 300 - 2400 baud and XMODEM protocols. To call, set your terminal program for;

- 8 data bits
- 1 stop bit
- No parity
- Echo Off
- Baud to the highest baud rate (up to 2400) that your modem supports.

**NOTE:** Some long distance calls get a lot of noise on the line and become almost unusable at 2400, if this happens, changing to a slower baud rate (1200) usually works much better (you cannot do this while on-line, you must hangup and call back at the new baud setting).

The number is not a toll free call, all calls will be billed by the phone company to the callers number. The BBS will not accept charges for long distance calls so be sure that the person who pays the bill (if not yourself) is aware of your calls and the phone number you are calling. All questions about the BBS or it's use should be addressed to "SYSOP" if left on the board or David Goforth if mailed to COMPUTIST. The BBS will change and grow rapidly in the first few months as new areas and features are added. If there is something specific that you would like to see incorporated please let us know.

Many people think that the magazines should be made available on the BBS for downloading. I agree but what you will get will be: An all text version of the issue, graphics have been done with a Mac and are in such a format and resolution that not even the IIgs can display them. So for hardware projects you would not have any drawings or schematics to look at. Also Program listings would still be that, text listings, and the biggie; Can you call long distance, spend 30 plus minutes downloading (if the file is compressed), and print out the magazine (not counting having it bound) for less than \$3.75 an issue? If so then please let us know your secret so we can save some money too.

All those who have the indexes (free ones) for all the COMPUTIST magazines that want to share it with others, please send it as soon as possible and I will incorporate it into the BBS. If at all possible (depending on the format - preferably Appleworks DataBase or text) I'll include a search routine for people to scan the index for specific topics, programs, etc.

One more word about this new volunteer, I own an Apple IIgs with the PC Transporter and can read the following disk formats; Apple 5.25 (140K), Apple 3.5 (800K), IBM 5.25 (360K), and IBM 3.5 (720K) so you can submit your inputs on any of the above disk formats for publication, hopefully this will allow for more IBM users to send inputs. All inputs should be submitted in standard ASCII text files if possible without any embedded special formatting codes and returns only at the end of paragraphs. This will greatly reduce the amount of time it takes to edit the submissions for publication. Also, any programs or hex listings should be sent in their original format (Basic and Binary files should not be converted to text). For more information of submissions please read the Readers Data EXchange printed at the beginning of every issue of COMPUTIST.

**PS.** Add one more subscriber. As I was writing this I 'chatted' (on the Gopher Hole BBS) with a caller who has been using an Apple IIe for over five years and never heard of COMPUTIST (and living in Tacoma, WA no less). He recently cancelled all other magazine subscriptions because of all the ads and very little information that they were publishing. He had no idea that this type of publication existed and really wants to see it. All it takes usually is to tell someone about COMPUTIST, then show it to them. Don't tell them the cost, let them see it for themselves when they see the magazine. Their reply is usually something like, "It's kind of high but there's no ads and you don't see this info anywhere else and I've subscribed to all Apple magazines in the past...". They usually end up joining and if you ask them about the cost you usually get something along the lines of, "No problem, I'll just drop these other two that I don't read anyway and even save a few bucks for something better...". You'd be surprised how easy it is, just tell and then show. Let the magazine speak for itself and the person decide. The only thing you have to watch out for is to be sure that you get YOUR copy back.

**PPS.** Oh, before I forget!! The Computist BBS phone number is (206) 581-9292. Hope to "see" you soon.



# The PRODUCT MONITOR

## RATINGS

☆☆☆☆	SUPERB
☆☆☆☆	EXCELLENT
☆☆☆	VERY GOOD
☆☆	GOOD
☆	FAIR
?	POOR
??	BAD
X	DEFECTIVE

Hopefully, your Christmas money piggy bank yet retains a few coins earmarked for entertainment software purchases. As promised last issue, this month's focus is upon several promising game releases. Next time, for sure (?), I shall put the wraps on all but end-of-year '89 funware and zero-in upon utilities.

### Pool of Radiance

☆☆☆

\$44.95 for 128K Apple II  
Cluebook: \$12.95

Beyond any question, 1989 produced absolutely the best crop ever of quality computer adventures; which, I hope, explains why so many good products— for example, SSI's Advanced D&D releases— are only just beginning to get the attention they deserve. In "Pool of Radiance" your party of up to eight heroes is launched upon a long-playing quest to deliver the city of New Phlan from the evil machinations of a mysterious arch-criminal known only as "The Boss". To this end you undertake a series of City Council "commissions" to obtain key artifacts, treasures, lost lore, AND, sometimes, take on the task of clearing one of the monster-infested suburbs. With each success your party attracts increased notice from the Boss's stooges (and their minions) until, finally, you tackle the Boss himself.

Though you will, occasionally, find yourself on an Ultima-style map of the nearby Wastelands, most of "Pool"'s action is set in the city's "Civilized Area", a suburb, or underground, in a dungeon. Here, and in some special Wilderness locations, you get a rather bland 3-D perspective view offering just enough detail for identification of buildings, doorways, arches, etc.. (This game badly needs a hefty dose of IIgs super-res and sound.) Aside from helping to fill-in some thirty-odd maps, your explorations can yield treasure, weapons/armor caches, and valuable information, supplied via a reference to one of the Journal or Tavern Tales entries in the game's "Adventurer's Journal" booklet.

Explorations also produce confrontations. Upon an encounter, the program displays a picture of one of the encountees (e.g. a hulking giant) and, more often than not, allows at least a chance at avoiding conflict. Should hostilities ensue, your party plus the enemy's forces appear on a scrollable combat map and the REAL fun begins! While a "Quick" option permits speedy, satisfactory computer resolution of easy battles, getting to crunch (blast, slice, ...) monsters is, after all, one of the big payoffs for your labors—and "Pool" offers one of the better tactical combat schemes around.

Since race, occupation, and attributes are very similar to those found in "Ultima", "Eternal Dagger", etc.— as, in fact, are the magic, weapons, and armor systems— this is a game you can expect to start and 'get into' with a minimum of hassle. With a scenario boasting mystery, humor, and the promise of ever more challenging adventure, getting out is not so easy! (Supplied on four double-sided diskettes, "Pool of Radiance" comes with manual, "Journal", and decoder wheel— to which I strongly recommend adding the map-filled "Clue Book".)

### The Duel

☆☆☆☆

\$44.95 for 512K IIgs  
The Supercars: \$19.95  
The Muscle Cars: \$19.95

California Challenge: \$19.95 (needs 768K)

The first time I tried Accolade's "Test Drive" (\$34.95 for 128K Apple II) my reaction was something like "This is a darn good game"; and, then, "I bet that if they release a IIgs version, it'll be fantastic". Well, they did, and it is. "The Duel" comes with two cars: the Porsche 959 and Ferrari's F40. As in the first "Test Drive", you can check out a picture + specs display for each car; and, each car actually does offer its own distinctive 'feel'. "Super Cars" adds five hot sportsters to your stable (including the '89 Corvette ZR1 and,

my favorite, the '85 Lamborghini Contach 500S); while, in "Muscle Cars", you get five monster engine legends from the '60's (e.g. the 425 hp '69 Dodge Charger Daytona, the 550 hp COPO ZI-1 Camaro, etc.).

Race the clock or tackle a computer-controlled competitor, either way you select the cars AND the course. So far, Accolade offers two "scenery sets". The game diskette set takes you through forests, mountains, and deserts; whereas, "California Challenge" amounts to a north-south tour of the state's more spectacular sites (e.g. redwood forests, ocean coasts, etc.). Even at high speeds, each set is good for several minutes— much more if you get caught by the highway patrol. Settable skill level adjusts the frequency of hazards like oil slicks, rocks, and traffic. (When you're tooling along at 200 mph, ANYTHING on the highway is a hazard!)

With joystick control and your behind-the-wheel super-res view, "The Duel"'s smooth animation and realistic sound come about as close to putting you on the road in a four-wheeled rocket as is possible. Even the necessary memory updates are masked via periodic service stops, where, beside fuel, you get an evaluation of your driving performance. (Naturally, top scores for each course are maintained on disk.) Aside from a documentation error which specifies CTRL-J and CTRL-K for joystick/KB control selection (J and K are correct), and the apparent requirement (undocumented) that RAM disk be OFF, "The Duel" has proved a flawless performer, good for many hours of enjoyable road-burning.

### The Usurper: Mines of Qyntarr

☆☆

\$29.95, includes 128K Apple II  
and 512K IBM versions

Sir Tech's new TEXT-only release sends you into the dreaded Mines to recover the Orb of Baellon— the latter being the fabled key to disposing of the evil Usurper. Encompassing well over 100 'rooms', "The Usurper" is a Zork-like adventure offering prosaic descriptions, interesting places and personages, and several worthwhile puzzles. Parsing (i.e. how well the program understands user inputs) is several notches above Eamon grade; but, still, just adequate, considering the tasks at hand. Often, for instance, Usurper fails to recognize items mentioned in its descriptions; and, sometimes, misses obvious substitutions. (e.g. "Get Scrap" will not suffice to pick up a Scrap of Parchment.) Happily, once you adjust to the game's moderate smartness level, 'playing the parser' situations are minimized; and you can concentrate on the adventure. Supplied with an attractive illustrated manual, "The Usurper" is cute, entertaining, and good for several evenings of play.

### Fast Frames, Updates, Etc.

#### Wiz V: Kettles & False Mazes

Dr. Hackenbush's question in #68 provoked a look through my "Wizardry V" notes, and, very probably, has re-hooked me on finishing the quest. This IS one of the great adventures. As to where to find the Laughing Kettle: on Level I at coordinates 22 East, 23 North, there is a secret door in the north wall which leads to the Kettle. He offers some useful clues for prices ranging from \$500 through \$5000. (Incidentally, don't be fooled by his jolly appearance. If attacked, the Kettle proves to be tough, powerful magic user; AND, should you win, the temple healers will require that you pay for his resurrection!)

The false mazes encountered by some "Wiz V" players ARE very strange places (places, in fact, where you are not supposed to be); but the phenomenon is not the result of some bug. (In the first batch of "Wizardry V" packages shipped, some did have bad diskettes— quickly replaced by Sir Tech— but, these simply crashed the game.) Rather, the problem stems from player errors which go undetected because 'correct diskette' verification is limited, mainly, to occasions when you move from one level to another. For example, if you take an elevator to Level 3, the program will insist that Level 3's diskette be in place before play continues. If, once on Level 3, you should swap in Level 5's diskette, the program will try to construct a maze from (and do updates to!) whatever it finds. Naturally, the Level 5 'player copy' diskette is ruined; and you find yourself in an oddly 'inside-out' maze which can look just genuine enough to occupy your best mapping skills for an hour or so.

My excursion into a false maze began when, using Roger Wagner's "Soft Switch" (on a IIgs), I decided to jump back to an earlier position on another level and forgot to swap in the new level's diskette. Well, the program had no way of knowing that some sly user was playing fast and loose with the adventure. It went merrily along, reading from and WRITING TO the other level's diskette; I ended up mapping a hefty chunk of "Wizardry V"'s 'twilight zone', and the diskette side was bombed. A reasonably satisfactory cure is to get out your set of originals and recopy the side that's been damaged. Everything on the restored level will be reset— you may have to reopen a few locks, etc.— but, at least, the quest can continue.

### Fast Break ☆

To work, a basketball simulation must be able to take the necessarily limited inputs from a user and 'fill-in the gaps'. When it succeeds, as in Activision's "Two-on-Two", you discover that control is easy and your man looks and acts like a basketball player. When it fails, as in Accolade's "Fast Break" (\$44.95, for 768K IIgs), you have a gang of impossible-to-control stumble bums.

### Tomahawk ☆☆☆

I suppose that, as long as I'm going to repeatedly refer to "Tomahawk performance" in joystick reviews, it's a good idea to say something about the best flight sim program available to IIgs users. Basically, the game puts you in the cockpit of an AH-64A Apache attack helicopter (code name: "Tomahawk") armed with a 30 mm automatic cannon, 38 rockets, and 8 'smart' Hellfire missiles. The super-res display presents a through-the-windshield forward view, an optional war map insert, and high-tech instrument cluster (comprehensive ship status displays and clickable controls plus locator and targeting aids). Very nice; and, when you throttle-up, you'll hear the whine of your engines and thuk-thuk-thuk of the rotors in (optional) stereo!

Missions range from "Training" through three increasingly difficult combat scenarios. To up the challenge level, you can select a higher pilot rating and/or toggle such options as "Night", "Cross winds", and "Cloudy" (with a user-settable cloud base down to 50 feet). Thanks to excellent instrumentation, you COULD fly your Tomahawk through a cavern at midnight— fortunately! While the 3-D line drawings (of buildings, mountains, tanks, enemy choppers, etc.) provide reliable visual distance cues, when you're over bare ground only the altimeter supplies any indication that you are about to plow into the turf.

Using joystick + mouse controls, Tomahawk is easy to fly; but flying well (i.e. landing and combat) definitely takes practice. Indeed, since you are flying without benefit of critical body position and middle-ear sensory cues, mastering DataSoft's Tomahawk probably means you're ready for a shot at the real thing! (I wonder if the Army would be interested in a little experiment.) Whether you seriously take on a combat mission or just enjoy zipping around and blowing up enemy targets, "Tomahawk" is first rate flight simulation fun. (\$29.95 for 512K IIgs)

### Deathlord ☆☆

When the Ninth Emperor commands you to root-out the "source of evil" threatening all Lorn, your six heroes begin a large-scale quest spanning sixteen continents packed with towns, ruins, dungeons, etc.. Looking and playing much like "Ultima III" done in Japanese, "Deathlord" locates all action on one's numerous maps (i.e. no forward-view mazes, monster close-ups, etc.). Character differentiation is exceptional— you have lots of races, 'occupations', and attributes to adjust— and the 84-spell magic system offers a nice range of powers. The scheme for combat, however, is about as simple as any non-tactical setup you are likely to encounter.

"Deathlord" delivers a crisp, attractive hires display and a scenario loaded with mini-challenges. (The Electronic Arts 200-plus-hours playing time estimate is probably not an exaggeration.) On the debit side, sound is barely adequate, fighters must choose from a small range of (poorly documented) weapons and armor, and all of the key designations (race, class, weapon, armor, and spell names) are in Japanese. While the latter feature adds a touch of authenticity; it would be would work better (i.e. be more fun and less bother) if the Japanese terms were accompanied by direct translations.

Possibly, the game's most serious weakness is the failure to match new character abilities to level of challenge. Since things are set up to present a stiff test for any developed characters you may transfer (from "Ultima III", "Wizardry I-III", or "Bard's Tale I"), "Deathlord" tends to chomp beginning heroes like peanuts. Another flaw, placing character creation and party formation in a separate utility (i.e. you must re-boot), makes 'learning the ropes' all the more cumbersome. 'Getting into' "Deathlord" definitely demands more raw effort than it should. Too much? If you especially enjoy big map, long-play 'old Ultima' adventuring, probably not. (\$39.95, for 64K Apple II)

### Becoming a Deathlord Survivor

Possibly, you are enmeshed in "Deathlord" (or, eventually, will be) and are perplexed by 'hero die-off'. (Even Gorbash, winner of Ultima's IV and V, M&M I and II, etc., put "Deathlord" on the back burner for a few months.) One solution, as usual, is 'super-natural intervention'— i.e. you diddle a few character parms and, SHAZAM!, your guys suddenly feel stronger, faster, smarter, and richer! A second trick is to minimize the damage should a 'worst case scenario' eventuate.

First, the SHAZAM solution: Using Central Point's "Copy II Plus" (\$39.95, for 128K Apple) and DOS alteration data found in Rob Fiduccia's "Deathlord" article in issue #63, we scanned the Scenario A diskette and found character data in sector \$0D on track \$13. (1. Go to 5.25" Bit Copy. 2. In the Sector Editor enter "P" to get to the DOS patcher and then "Custom". 3. Under "Address",

change D5 AA 96 to D5 AA D6 and DE AA to DE B7. Under "Data", change D5 AA AD to D5 AE AD and DE AA ... to EA AA ... 4. Exit the patcher and Read T/S \$13/\$0D. NOTE: Should you wish to scan the diskette starting at track \$0, expect to encounter a few unreadable sectors along the way. Just skip these and continue.)

On the Sector Editor screen, you should find character data arranged in six-byte groups (one byte per character) as follows:

\$42:	Hit Points, max (low byte)
\$48:	Hit Points, max (high byte)
\$4E:	Hit Points, current (low byte)
\$54:	Hit Points, current (high byte)
\$66:	Level
\$72:	Strength
\$78:	Constitution
\$7E:	Size
\$84:	Intelligence
\$8A:	Dexterity
\$90:	Charisma
\$96:	Power, current
\$9C:	Power, max
\$CC:	Age
\$D2:	Food
\$D8:	Gold (low byte)
\$DE:	Gold (high byte).

Edit as desired, write your SHAZAMED characters back to disk, and your quest against the Deathlord is a 'whole new ball game'.

Granted, if you max-out every parm and give each character \$10,000 gold, there isn't much your party can't handle. If, however, you merely go for a "fair start", then the inconvenience associated with having several characters wiped out remains a threat. You can make a character backup each time you start the game; but, of course, you won't. It's too much bother, the backup won't restore hours of progress made in the current session, and, besides, there's a better way! Use the "Make Scenario" function to create a copy of each current scenario diskette on its unused side. During play, you just do an occasional SAVE on alternate sides. If your party is wiped out and saved as dead on Side One, you can restart from Side Two, etc.. Whatever happens, you will never lose more than the progress made since the last opposite-side SAVE.

### Vendors

- Accolade: 20813 Stevens Creek Blvd., Cupertino, CA 95014 (408-446-5757)
- Central Point Software: 15220 N.W. Greenbier Parkway #200, Beaverton, OR 97006-9937 (503-690-8090)
- Electronic Arts: 1820 Gateway Drive, San Mateo, CA 94404 (415-571-7171)
- Intellireations/Datasoft: 19808 Nordhoff Place, Chatsworth, CA 91311 (818-886-5922)
- Sir-Tech: P.O. Box 245, Charlestown Mall, Ogdensburg, NY 13669 (315-393-6633)
- Strategic Simulations Inc.: 1046 North Rengstorff Ave., Mountain View, CA 94043 (415-964-1353)

### Charles Taylor CA

Softkey for...

### Soko Ban

Spectrum Holobyte

#### Requirements:

Apple IIe or IIc (128K)

Jim Hart's softkey for Tetris (COMPUTIST 62, page 23) may have been a "half-key" for Tetris, but it is a full-key for Soko Ban. Soko Ban is a strategy game in double-hi-res of a warehouseman trying to move boxes through a maze to the loading dock. There are 50 different mazes on the disk, so it should provide hours of entertainment (or frustration).

The Soko ban disk is normally formatted, except that the epilogues have been changed to FF FF instead of DE AA. Once this has been corrected, Jim Hart's Tetris "half-key" can be used, except that the code is in a different location. Jim saved me many hours of work by publishing the bytes that he found on the Tetris disk. Many softkey contributors do not send in a listing of the code that needs to be changed, rendering that softkey useless for slight alterations in the copy protections.

1. Boot your DOS 3.3 system disk.
  2. Tell DOS to ignore checksum and epilog errors and use COPYA to copy both sides of the Soko Ban disk.
- POKE 47426,24  
RUN COPYA
3. Make the following sector edits to the copy.

Trk	Sc	Byte(s)	From	To
00	05	0C-29	A9 0A 85 FC A6	A9 E7 85 F8 85
			2B BD 89 C0 BD	FB A9 FC 85 F9
			8E C0 A9 80 85	85 FC 85 FF A9
			FD C6 FD F0 71	EE 85 FA 85 FD
			20 AF F0 B0 6C	85 FE A6 2B BD
			A5 F9 C9 00 D0	80 C0 18 90 52

I read your editorial on your financial problems, and have two suggestions. 1. Raise the rates. I don't think \$5 per issue is unreasonable. 2. Try to get your mag into computer stores and software stores. This would get store sales plus increased recognition of a unique publication and lead to more subscriptions.

Raising the rates might seem like a solution, but it's not and I only brought it up in order to eliminate it. If we raised the rates, more readers would not renew and the rates would have to go up again, and more readers would not renew and the rates would go up, and more... A vicious cycle and not one that we want to get caught up in.

As to computer stores, we try that one on a regular schedule but the results are not encouraging. Most stores do not buy magazines direct. They use a periodical service that keeps their racks loaded. These periodical services do not pay up-front, instead, they pay up to 120 days later. And they like to order a lot of issues but they claim that they don't sell all of them and that they had to burn/destroy most of the copies (about 90%). One periodical service sent us affidavits claiming to have destroyed more copies than we had sent them. So you can see that it's a lot more involved than it seems and there are a lot of rats out there. Some smaller stores do order direct, but they don't make a lot on magazine sales and they don't like you to see how low the mail order prices are and they don't want you to know how to backup your software and so on... Another dead end, but we keep trying and we do have a few regular dealers, mostly in foreign countries. .RDEXed

## George Sabe PA

I would like to share the following softkeys with your readers.

Softkey for...

### LA Crackdown

Epyx

#### Requirements:

COPYA

Sector editor (such as Copy II Plus)  
2 blank disks

1. Boot your DOS 3.3 system disk.
2. Tell DOS to ignore checksum and epilog errors and use COPYA to copy the disk.

POKE 47426,24

RUN COPYA

3. Make the following sector edits to the copy.

Trk	Scr	Byte(s)	From	To
00	05	10	A6 2B BD 89 C0	A9 E7 85 F8 A9
			BD 8E C0 A9 80	FC 85 F9 85 FF
			85 FD C6 FD F0	A9 EE 85 FA 85
			71 20 AF F0 B0	FD 85 FE A9 F3
			6C A5 F9 C9 0F	85 FB A9 70 85
			DO F1 A0	FC DO 50

4. Write the sector back to disk.
5. Copy side 2 with any copy program. It is in normal format.

Softkey for...

### Into the Eagles Nest

Mindscape

#### Requirements:

COPYA

Sector editor  
One blank disk

The softkey in Computist 66, p23, by Zorro was of great help. My copy had altered epilogs and required further modifications.

1. Boot your DOS 3.3 system disk.
2. Tell DOS to ignore checksum and epilog errors and use COPYA to copy the disk.

POKE 47426,24

RUN COPYA

3. Make the following sector edits to the copy.

Trk	Scr	Byte(s)	From	To
00	07	0C	38	18
00	08	63-65	BD 88 C0	EA EA 60

4. Write the sector back to disk.

Softkey for...

### Jump Jet

Avant Garde

### Mission Escape

Microsparc

These two programs use modified epilogs and can be copied by poking 47426,24 to ignore epilog errors and running COPYA to produce a working copy.

1. Boot your DOS 3.3 system disk.
2. Tell DOS to ignore checksum and epilog errors and use COPYA to copy the disk.

POKE 47426,24

RUN COPYA

Softkey for...

### Tag Team Wrestling

Data East

#### Requirements:

COPYA

Sector editor

1. Boot your DOS 3.3 system disk.

2. Tell DOS to ignore checksum and epilog errors and use COPYA to copy the disk.

POKE 47426,24

RUN COPYA

3. Make the following sector edits to the copy.

Trk	Scr	Byte(s)	From	To
00	05	4B-4C	DO F4	EA EA
		54-55	DO 36	EA EA
		5D-5E	DO 2D	EA EA
		70-71	DO F4	EA EA
		7B-7C	DO 0F	EA EA

4. Write the sector back to disk.

Softkey for...

### Cutthroat

Infocom.

This program can be copied by following the softkey for Sorcerer (Infocom) in Computist #51, page 35 by Jack Nissel.

Softkey for...

### Cavern Creatures

Datamost

Congo

Sentient

These two programs require a way to reset into the monitor. I used the Senior PROM. They can be copied using the Newspaper Controller or similar copy program. I used COPYB.

#### Cavern Creatures:

1. Initialize a blank disk with a fast DOS.
2. Boot the original and reset into the monitor.
3. Capture the RWTS and copy using the Newspaper Controller.

#### Congo:

1. Initialize a blank disk with "BOOT" for the hello filename.
2. Boot your original and reset into the monitor.
3. Capture the RWTS and copy using the newspaper controller.

I would like to comment about the new format. Although I realize the need for change to save Computist and would be willing to accept any change to cut expenses, but I would much rather have the old smaller format. I would be happy with loose leaf binder type pages if they are smaller since they can be filed easily with the old issues. Also, I would like to see you publish a small book about different protection methods and ways to bypass it. It should be in-depth with comprehensive explanations. I am sure several of your contributing readers are capable of writing such a book and I feel most of the other readers will purchase it.

## Captain Video PA

I am writing in response to your questionnaire in issue 66 of Computist.

First, I would like to commend you for a fantastic magazine. I have been into computers for about three years, and I have learned more about my Apple GS from Computist than any other source. I feel it is well worth the \$32.00 subscription price.

1) I would love to get Computist every two weeks with the tabloid form. I would be willing to pay the extra money for the increased subscriptions.

2) I think the Beginner's Notebook is a great idea. This would help to keep new subscribers from being overwhelmed by the articles in Computist. It would help keep them interested, which would result in their renewing their subscriptions.

3) I like the idea of bounties for stubborn programs that are on the Most Wanted list.

4) I think the free software giveaway is a good idea to motivate readers to write better articles. I don't believe there should be categories, just the three or four best articles in each issue.

5) The help line is also a great idea, but a lot of work for the volunteers. I could think of a lot of questions to ask.

6) The reader's Wish List is also a good idea to motivate readers to find new subscribers. The point system is a great way to run the program, but more work for everyone at your end. All of the above ideas are great, but I don't know how you are going to find enough time to do it all.

7) I do not think lowering the rates will increase the number of subscribers by any substantial number.

8) I don't mind the tabloid form for Computist, just as long as they keep coming.

9) I would accept raising the rates to \$48.00. I prefer this to cutting the number of issues to eight per year, although I would be willing to accept this, also. My first vote is to double the number of yearly issues with the tabloid form to justify the price increase.

Although Computist is by far the best Apple magazine on the market, I believe the above changes will make it even better. Whatever has to be done, I'm sticking with you. I believe the money I've spent on Computist has been the most wisely spent money that I have put into computing.

## My wish list

1. Battle Chess GS by Interplay Productions
2. Zoom! GS by Discovery Software
3. Calendar Crafter by MECC
4. World Geography by MECC
5. Fire Power GS by Microillusions
6. Mad Match by Baudville
7. Hostage by Mindscape
8. Sword of Sodan GS by Discovery Software
9. Star Saga: One by Masterplay Pub. Corp.
10. Fingerprint GSi by Thirdware Comp. Prod.

I would also like to send in my first softkey for the Apple GS.

Softkey for...

### Impossible Mission II GS

Epyx

#### Requirements:

512K Apple II GS

3.5" disk copier

3.5" disk editor

The copy protection is a nibble count on tracks 20 and 21. Copying the disk will produce no errors or bad blocks. Booting the copy produces the message to insert the master disk, a sign of a nibble count. Use your 3.5" disk editor to scan for the hex code A2 20 A0 01. The code was on block \$04A3 on my disk. At the very beginning of block \$04A3 I found this:

01: D0 64 BNE 1167

03: 20 60 2D JSR 2D60

The code for the nibble count begins on byte 46. To break this protection, change the JSR instruction (20) to a LDA instruction (AD). This will stop the nibble count check and the disk will be deprotected.

1. Copy the disk.
2. Scan disk for A2 20 A0 01.
3. Locate the JSR routine 20 60 2D. (Mine was on block \$043A, beginning with byte 03.)
4. Make the following edit:

Blk	Byte(s)	From	To
4A3	03	20	AD

5. Write the edit back to disk. That's it!

## Brian A. Troha WI

There are a few things I would like to comment on:

First, should COMPUTIST include other machines? Yes, only if it will ensure the continuation of the magazine. It's funny, I used to think if it wasn't an Apple IIs program I didn't want to know about it. Then friends kept asking me to crack all these IIs programs for them. Now I find I like cracking any Apple software. If I had a Mac or an Amiga (or even an IBM, gasp!), I'd get into cracking programs for those machines. Right now I don't have either, but I still like to read about the copy protection schemes. Some day it may come in handy.

Second, the tabloid format: I hate it!, but if you need to use it to continue the magazine, then I'm for it. The idea of the year-end book style of previous issue is great. Think of it as a Tome of DeProtection '89 and etc. for the following years. Wouldn't it be nice to pick up a book (about the size of a small dictionary) and flip through a years worth of articles and find what your looking for?

Third, fake softkeys! This really bothers me! If you can't come up with something for real don't fool us with trash. As the RDeX prints what is sent in, they/we are forced to trust our writers, so let's not mess that up.

Fourth, I really don't like the idea of someone sending in 70 or so patches saying "here's my patch collection". I have a list of patches with around 95 programs on it. These are the most complete and accurate patches anywhere. Most are my work, however there are some from other authors or, at least, from their ground work. You could have nearly the SAME list as I have if you go through past issues of COMPUTIST and compile the patches, it's not really that difficult to do. Sure that's nice and all, but every author that worked on the articles that the patches came from deserve credit.

As an example: For some of my softkeys, it will take me anywhere from 5 minutes to an hour to crack and test a program. It can take several hours or days to try to tackle programs like Tomahawk, Hunt For Red October, and Dungeon Master. Then it's another hour (at least) to list the copy protection, type it in and add comments, and finish the article over all. Then get them together and send them in for others to read and learn from. I'm not getting rich doing this and that's not my intention, I want to teach others how to crack. Just like the late great ones: Disk Jockey, Reset Vector, Parity Error, etc. The point is: Credit is MY payment and nobody likes to get ripped off!

Softkey or APT: Well it's time to redefine Softkey (which was defined before the GS) as something like the following:

Softkey is a term which we coined to describe a procedure that removes, or at least circumvents, ANY copy-protection on a particular disk. Once a softkey procedure has been performed, the resulting backup copy can be copied by normal copy programs (COPYA, Fastcopy.system, etc). Such copies will no longer require a Keydisk or

the entry of a Keyword to run.

And now for a new word:

Hardkey is a term which was coined to describe a procedure that allows a non hard disk compatible program to be moved to/run from a RAM or hard disk. (examples: Mean 18 in COMPUTIST #68 & Bubble Ghost in COMPUTIST #71)

To Derek: Black Bag was NOT a user group, it was a pirate group now since disbanded. They had some talented people, I think they were the first to crack and release Wings of Fury in the pirate world.

I recommend the following two block editors for people who wish to start cracking software on the Apple IIs:

The one in Copy[+]: Just fine for making known patches and searching the entire disk for bytes.

Block Warden from ProSEL: This editor is very good, it has a follow file feature (as CP routines are usually in the 16 bit program file). The disassembly will follow the REP & SEP commands, that is the changing from 8 bit to 16 bit Accumulator and index registers. ProDOS 8 and ProDOS 16 calls are listed properly and Block Warden tells you which call it is. The block editor is worth the money for the whole ProSEL package by itself. Then you get the rest of the programs with ProSEL, an awesome bargain!

I used to use Copy[+] because I knew how to do everything manually, like finding the Key Block of files and such. Now I use Block Warden, as it's much more powerful and automated.

Warning: I have decided to write the following for everyone's benefit. If I make a comment about the way individuals do things, PLEASE do not take it as an attack. I'm trying to explain the why and why not. Also, I'm NOT saying "I'm better", just passing along a few lessons and some information.

Let me begin with "encrypted code" (see Dan Halfwit's King of Chicago, Computist #68, page 13). When 16-bit system files are written (the \$B3 or \$16 file types) they contain segments or pieces of programs "linked" (or spliced) together. These files are usually written as relocatable due to the varying machine setups, that is, the amount of memory and number of CDA/NDAs installed. So, in memory, a JSL 034567 could show up as ANYTHING on the disk or just a plain JSL 000000 (Sierra comes to mind, right?). So when you make an absolute reference it might not work with every machine.

I found this out when I went to deprotect Draw Plus (Activision) and the program kept bombing. I overwrote a small section of code with EA's and, when it loaded in the ProDOS 16 loader, made the changes to the relocatable instructions. This is the reason you see so many GS cracks changing JSL (22) to LDA (AF) and JSR (20) to LDA (AD). The idea is to keep the instruction the same length and not care if the absolute address changes. We don't mind if the program LDA 0000, LDA FFFF, or anywhere in between as long as it doesn't go through the protection routine. Again, I'm not saying Dan is totally wrong, in fact he is right on the money. The only problem is he goes about the edits as though the GS programs are like IIs programs.

Now I would like to propose a the following procedure (that I use):

1. Figure out what kind of copy protection is used

2. Find the copy protection routines
3. Look for flags or special memory references

4. Kill the calls to the copy protection
5. Force the flag checks to pass

This reminds me of the time I used to go to summer camp. We played two team styled games: Capture the Flag & Spy vs Spy

Capture the Flag: You take two flags (and two teams) and set them a reasonable distance apart. You split your team into two groups: 1. Team A: Finds the other flag, grabs it and tries to run it back to it's own game area. 2. Team B: Tag the opponents Team A members who must now give up the flag or freeze for a period of time and most important guard their own flag.

Spy vs Spy: Take a same piece of paper with a point value written on. Hide it on your person. Try to run to your headquarters without being tagged by a member of the other team. If you are tagged the other team is allowed to search through your clothes (to a reasonable limit) to find the paper. This, by the way, is one of the best co-ed contact games I know of!

So why tell you about these games? Well we're all playing a combination of the two. Our team: Computist readers/members/RDEX and "The Other Guys": Software protectors. As you can see we have the numbers and the combined skill to beat them EVERY time. Think about it: If you cannot crack a program, chances are one of your 3800 or so team members can! This is our greatest strength. As an example:

Softkey for...

### King of Chicago

Let's work with King of Chicago (Although I no longer have access to copies I'll tell how I cracked it). We know they have a flag somewhere in their code "game area." Our job: Find it, and bring it back (thus taking it out of the pro-





1F5:A0 01 LDY #01 and the side  
 1F7:5A PHY Push side  
 1F8:DA PHX Push track  
 1F9:F4 C0 50 PEA 50C0  
 1FC:F4 C0 50 PEA 50C0 Push ptr to disk name  
 1FF:22 C1 00 06 JSL 0600C1 Count them up  
 003:8D BB 50 STA 50BB Temp store Accum (should = 00)

006:68 PLA  
 007:68 PLA  
 008:68 PLA  
 009:68 PLA  
 00A:68 PLA  
 00B:68 PLA Pull all pushed info off stack

00C:AD BB 50 LDA 50BB Load the returned value  
 00F:80 4F BCS 060 (+4F) Carry set is I/O error or wrong disk

011:8E BC 50 STX 50BC Store low order of nibble count sum  
 014:8C BD 50 STY 50BD Store high order of nibble count sum

017:A2 21 LDX #21 Now for track \$21  
 019:A0 01 LDY #01 same side  
 01B:5A PHY Push side  
 01C:DA PHX Push track  
 01D:F4 C0 50 PEA 50C0  
 020:F4 C0 50 PEA 50C0 Push pointer to disk name

023:22 C1 00 06 JSL 0600C1 Count them up  
 027:8D BB 50 STA 50BB Temp store Accum (should = 00)

02A:68 PLA  
 02B:68 PLA  
 02C:68 PLA  
 02D:68 PLA  
 02E:68 PLA  
 02F:68 PLA Pull all pushed info off stack

030:AD BB 50 LDA 50BB Load the returned value  
 033:80 2B BCS 060 (+2B) Carry set is I/O error or wrong disk

035:8E BE 50 STX 50BE Store low order of nibble count sum  
 038:8C BF 50 STY 50BF Store high order of nibble count sum  
 03B:C2 30 REP #30 Set 16-bit wide Accum & index regs  
 03D:AD BC 50 LDA 50BC Load track \$20 nibble count sum  
 040:C9 6C 20 CMP #206C Compare to low end bench mark  
 043:90 1B BCC 060 (+1B) If too low then goto fail routine  
 045:C9 03 21 CMP #2103 Compare to high end bench mark  
 048:B0 16 BCS 060 (+16) If too high then goto fail routine  
 04A:AD BE 50 LDA 50BE Load track \$21 nibble count sum  
 04D:C9 B0 1D CMP #1DB0 Compare to low end bench mark  
 050:90 0E BCC 060 (+0E) If too low then goto fail routine  
 053:C9 79 1E CMP #1E79 Compare to high end bench mark  
 055:B0 09 BCS 060 (+09) If too high then goto fail routine  
 057:C2 30 REP #30 Make sure we're in full 16-bit mode  
 059:A9 00 00 LDA #0000 Load a "pass" value  
 05C:8D 26 00 STA 0026 Store in the COPY FLAG  
 05F:68 RTL Return to caller  
 060:22 A4 00 06 JSL 0600A4 Part of FAIL ROUTINE  
 064:C2 30 REP #30 Make sure we're in full 16-bit mode  
 066:A9 01 00 LDA #0001 Load a "fail" value  
 069:8D 26 00 STA 0026 Store in the COPY FLAG  
 06C:68 RTL Return to caller  
 06D:00 00 50BB - Temp storage for Accum  
 06E:00 00 0000 50BC - Track \$20 nibble count sum storage  
 070:00 00 0000 50BE - Track \$21 nibble count sum storage  
 072:46 41 53 54 42 52 45 41 4B 50C0 - FASTBREAK (disk name to check for)

The routine is easy to follow and resembles most of the nibble counting routines that are used on the 3.5" disks. Tracing the program code back, I found a single call to the routine and made my patch there. The call is in the form of JSL 025029, (22 29 50 02) then the flag location 0026 was loaded and checked for a value of zero. If 0026 was zero the game would continue, if 0026 was any other value the game would jump to a ProDOS quit routine.

One thing I noticed about this release of FastBreak (the one that was recalled). I bought the program and when I got home the FIRST thing I did was to make a copy and remove the copy protection. After I thought I had removed the routine (in fact I had) I booted the game and tried to play but could not figure out what was going on. So I booted the original to see if the same thing happened and the ORIGINAL would refuse to run! After reading the instruction manual I figured out how to start playing. The deprotected copy would run just fine while the original would quit before the game started. After some checking I found the copy protection would always fail on the ORIGINAL! However a cracked version was playable, this just goes to show what copy protection does for everyone, including the publisher.

Note: The version of FastBreak that you buy could have a slightly different copy protection, or be in a different place. To deprotect a different version, search for A2 20 A0 01 and back up about 20 bytes and list it. Compare the listed code to the above disassembly from \$1E6 through \$1F5 and find the flag, the LDA #0001 & STA 0026, where 0026 is the flag I'm referring to. Then, search for those two bytes, that is 26 00, if the flag was 0026. You should find code something like:

Block \$A (on mine although it could be anywhere on yours)

```
1E0:22 29 50 02 JSL 025029 Do nibble count routine
1E4:AD 26 00 LDA 0026 Load the flag location
1E7:F0 04 BEQ 1EB (-04) Branch on zero (CP passed)
```

I found the above code about \$3E0 bytes into the file FASTBREAK.SYS16. To remove the copy protection change the JSL (22) to LDA (AF), the LDA (AD) to STZ (9C), and finally change the BEQ (F0) to BRA (80). This skips the actual disk check, sets the flag to zero for an "original", then it always continues with the program. For the original non-working copies of Fastbreak:

1. Make a copy of the game disk

2. Make the following edit to the copy only:

Blk	Byte(s)	From	To
\$0A	\$1E0	22 29 50 02	AF 29 50 02
	\$1E4	AD 26 00	9C 26 00
	\$1E7	F0 04	80 04

3. Write the block back to the copy

Now you can actually copy the game to a subdirectory on a hard disk if you want. The only drawback to the game is you must hit reset to quit, as there is no built in quit that you initiate. This was kind of dumb as there is a ProDOS 16 quit call in the program that is used when a copy fails the copy protection routine. It would have been easy to check for a CTRL-Q and send the program to that quit routine, then you would have had a fully hard disk compatible game. Even though the manual specifically says you cannot upload FB to a hard disk on the GS, you can after you remove the copy protection. Once again the software publisher doesn't know what they are talking about.

Softkey for...

### Final Assault

Epyx

Requirements:  
 512K Apple IIs  
 3.5" Disk copier  
 3.5" Disk editor

Final Assault (FA) is a new mountain climbing game from Epyx. It uses nibble counting on tracks \$20 and \$21 for disk protection. The routine is much like those found on two other Epyx releases; Street Sports Soccer and California Games. However, there is one twist that helps hide the routine from the crackers. Searching for the standard A2 20 A0 01 will not work for this program. Epyx loads the registers in full 16 bit mode then switches to needed 8 bit wide registers to hide the routine. So for this release the A2 20 A0 01 has changed to A2 20 00 A0 01 00, when searching for this sequence you will find the following (block \$354-\$355):

```
1CB:0B PHD
1CC:3B TSC
1CD:38 SEC
1CE:E9 F7 00 SBC #00F7
1D1:5B TCD
1D2:69 EA 00 ADC #00EA
1D5:1B TCS
1D6:AF 0E 00 02 LDA 02000E
1DA:48 PHA
1DB:22 00 00 0C JSL 0C0000
1DF:FA PLX
1E0:B0 56 BCS 038 (+56) An error, goto fail section
```

```
1E2:85 F0 STA F0
1E4:A2 20 00 LDX #0020 Track $20 in 16 bit
1E7:A0 01 00 LDY #0001 Side one
1EA:E2 10 SEP #10 Switch to 8 bit wide registers
```

```
1EC:5A PHY Push side
1ED:DA PHX Push track
1EE:A5 FF LDA FF
1F0:48 PHA
1F1:A5 FD LDA FD
1F3:48 PHA
1F4:22 C1 00 0C JSL 0C00C1 Count them up
```

```
1F8:85 F0 STA F0
1FA:68 PLA
1FB:68 PLA
1FC:68 PLA Pull extra values off stack
1FD:86 EE STX EE Store first half of sum
1FF:84 EF STY EF Store the second half
001:C2 30 REP #30 16 bit wide accum & registers
```

```
003:B0 33 BCS 038 (+33) Had a disk error, then failed
```

```
005:A2 21 00 LDX #0021 Track $21 in 16 bit
008:A0 01 00 LDY #0001 Side one
00B:E2 10 SEP #10 Switch to 8 bit wide registers
```

```
00D:5A PHY Push side
00E:DA PHX Push track
00F:A5 FF LDA FF
```

```
011:48 PHA
012:A5 FD LDA FD
014:48 PHA
015:22 C1 00 0C JSL 0C00C1 Count them up
019:85 F0 STA F0
01B:68 PLA
01C:68 PLA
01D:68 PLA Pull extra values off stack
```

```
01E:86 EC STX EC Store the first half of sum
020:84 ED STY ED Store the second half
022:C2 30 SEP #30 16 bit wide accum & registers
```

```
024:B0 12 BCS 038 (+12) Had a disk error, then failed
```

```
026:A5 EE LDA EE Load track $20 sum in 16 bit
```

```
028:8F 2B 0F 03 STA 030F2B Store it
02C:A5 EC LDA EC Load track $21 sum in 16 bit
```

```
02E:8F 2D 0F 03 STA 030F2D Store it
```

```
032:22 A4 00 0C JSL 0C00A4
```

```
036:80 0A BRA 042 (+0A) Branch of the fail section
```

```
038:A9 0C 00 LDA #000C Load a failed value
```

```
038:8D 97 00 STA 0097 Store in the flag
```

```
03E:22 A4 00 0C JSL 0C00A4
```

```
042:A8 TAY
```

```
043:38 TSC
```

```
044:18 CLC
```

```
045:69 0C 00 ADC #000C
```

```
048:1B TCS
```

```
049:98 TYA
```

```
04A:2B PLD
```

```
04B:6B RTL Return to the sender
```

After checking the above code, I decided that the STA 0097 (8D 97 00) had to be some kind of flag. I then searched the disk for 97 00 for all references to 0097. This reveals the following code on block \$447:

```
1A2:AD 97 00 LDA 0097 Load the flag
1A5:D0 14 BNE 1BB (+14) Anything but zero fails
```

```
1A7:AF 2B 0F 03 LDA 030F2B Load track $20 sum value
```

```
1AB:C9 40 1F CMP #1F40 Compare to benchmark (low)
```

```
1AE:90 0B CLC 1BB (+0B) If too high, then fail
```

```
1B0:AF 2B 0F 03 LDA 030F2D Load track $21 sum value
```

```
1B4:C9 D0 20 CMP #20D0 Compare to benchmark (high)
```

```
1B7:F0 08 BEQ 1C1 (+08) Equals is a pass
```

```
1B9:90 06 BCC 1C1 (+06) Or if it's higher, it passes
```

```
1BB:A9 01 00 LDA #0001 Load a fail value
```

```
1BE:8D 97 00 STA 0097 Store in the flag
```

```
1C1:22 74 08 06 JSL 060874 Continue
```

```
1C5:38 TSC
```

```
1C6:18 CLC
```

```
1C7:69 16 00 ADC #0016
```

```
1C9:1B TCS
```

```
1CB:2B PLD
```

```
1CC:6B RTL Return to the sender
```

This section of code is the deciding factor in the copy protection routine. One, it checks 0097 for a value of zero. Two, it loads the results of the nibble count and compares them to the low end of the benchmark values.

If you think about it; 0097 should equal zero, then we need to get down to \$1C1. I changed the LDA 0097 (8D 97 00) to STZ 0097 (9C 97 00) for the zero value, then the BNE 1BB (D0 14) becomes BRA 1C1 (80 1A) to get us down the continue section. Now, the one flag is set and the compare section is skipped over so the game will run.

The last addition I made was to bypass the actual disk reading routine, so I back traced the code and found a single call the first section of code I showed. This call is on block \$3BC and is in the form of:

```
0CC:F4 D5 33 PEA 33D5 Push disk volume name
0CF:F4 D5 33 PEA 33D5 D533 is relocated when loaded
```

```
0D2:22 8B 07 01 JSL 01078B Jump to the nibble count
```

```
0D6:7A PLY
```

```
0D7:7A PLY Pull extra values off the stack
```

With the main protections explained I would like to show you the steps:

1. Figure out what kind of copy protection is used. Epyx tends to use the 20/21 nibble counting scheme a lot. The only difference on this release is the use of the 16 bit wide registers.

2. Find the copy protection routines. Okay, so we know we have to use A2 20 00 A0 01 00 to find the code. I tried to show what it is doing in the above disassembly.

3. Look for flags or special memory references. We find that 0097 is used as flag for the "horrible death" and insult routine. The program stores the nibble counting results at 030F2B and 030F2D.

4. Kill the calls to the copy protection. Changing the JSL 01078B to LDA 01078B will work for this step.

5. Force the flag checks to pass. Doing the STZ 0097 sets the flag, and the BRA 1C1 forces the code past the benchmark tests.

Now that you get some kind of idea of the needed steps for defeating the copy protection on Final Assault (and in general), you only need to make the patch permanent. To finish things up,

follow these easy steps:

1. Make a copy of the game disk.
2. Make the following edits to the copy only.

Blk	Byte(s)	From	To
\$3BC	\$D2	22 8B 07 01	AF 8B 07 01
\$447	\$1A2	AD 97 00	9C 97 00
	\$1A5	D0 14	80 1A

3. Write the edits back to the copy.

Store the original in a safe place. Use the deprotected copy for playing.

The program is now cracked and the flag is captured! We get two more points, see how easy it is to rack up the points.

Softkey for...

### Children's Writing & Publishing Center

The Learning Company

Requirements:

128K Apple II (with Double Hi-res)  
 3.5" disk copier  
 3.5" disk editor

The Children's Writing & Publishing Center (CWPC) is just what the title says, it's a desktop publishing program for kids. Because educational programs are used by children they should always be unprotected and easily backed up. Children (and adults) can have accidents that tend to render computer disks unusable! So I will show you how to make as many backups as you need.

The program comes on two 3.5" disks and is using a bad block on the program disk for protection. After a little code snooping, I was able to track down the call to the protection and disable it. To make a deprotected copy of CWPC follow these steps:

1. Make a copy of both disks (ignore any block errors on the program disk)
2. Using a block editor make the following edits to the program disk

Blk	Byte(s)	From	To
\$3D8	\$79	20 13 11	EA EA 18

3. Write the block back to the copy

Store the originals in a safe place. Give the newly deprotected copies to your kids to use!

Softkey for...

### 4th & Inches:

### Team Construction Disk

Accolade

Requirements:

512K Apple IIs  
 3.5" disk copier  
 3.5" disk editor

4th & Inches Team Construction Disk (FITC) is a companion disk for the game 4th & Inches. With this new program you can change the players stats of the whole team, then save them to disk. You may also create entire new teams or add all the football teams you can think to FITC disk. Then you may select the teams you want to play with. If you really liked 4th & Inches, but you where starting to loose interest, you should go out and get this program.

FITC does a standard nibble count on your original 4th & inches disk to see if you're using an original game disk. I'm not really sure if FITC runs the nibble count on it's self, but I know for sure it runs the check on the game disk. The protection routine is located on block \$1BC of the disk and contained in the file START in the volume/SYSTEM subdirectory. The whole protection routine is as follows:

```
37:C2 30 REP #30 16 bit wide Accum.
39:20 85 7A JSR 7AB5
3C:E2 30 SEP #30 8 bit wide Accum.
3E:AD FD EC LDA ECFD
41:D0 2B BNE 6E (+2B)
43:EE FD EC INC ECFD
46:C2 30 REP #30 16 bit wide Accum.
48:A2 01 02 LDX #0201 MMB00Init
4B:22 00 00 E1 JSL E10000 Tool locator call
4F:B0 6D BCS C0 (+6D) If error then bomb
51:F4 00 00 PEA 0000
54:A2 02 02 LDX #0202 MMS00StartUp
57:22 00 00 E1 JSL E10000 Tool locator call
5B:B0 61 BCS C0 (+61) If error then bomb
5D:68 PLA
5E:8D FF EC STA ECFE
61:AD FF EC LDA ECFE
64:68 PLA
65:22 62 E8 02 JSL 02E862
69:68 PLA
6A:B0 52 BCS BE (+52)
6C:E2 30 SEP #30 8 bit wide Accum.
6E:A2 20 LDX #20 Track $20
70:A0 01 LDY #01 Side
72:20 C1 EC JSR ECC1 Jump to the nibble count
75:8E 01 ED STX ED01 Store half of result
78:8C 02 ED STY ED02 Store second half
7B:A2 21 LDX #21 Track $21
7D:A0 01 LDY #01 Side
7F:20 C1 EC JSR ECC1 Jump to the nibble count
82:8E 03 ED STX ED03 Store half of result
85:8C 04 ED STY ED04 Store second half
88:AD 01 ED LDA ED01 Load Track $20 result
8B:C9 00 CMP #00 Check first half
8D:AD 02 ED LDA ED02
```



90:E9 20 SBC #20 Check second half  
 92:90 2A BCC BE (+2A) If error then bomb  
 94:AD 03 ED LDA ED03 Load track \$21 result  
 97:C9 00 CMP #00 Check first half  
 99:AD 04 ED LDA ED04  
 9C:E9 1F SBC #1F Check second half  
 9E:B0 1E BCS BE (+1E) If error then bomb  
 A0:82 2D 00 BRL D0 (+002D) Branch to continue code

A3:5A PHY Push side  
 A4:DA PHX Push track  
 A5:F4 02 00 PEA 0002  
 A8:F4 F6 EC PEA ECF6 Push disk name/volume  
 AB:22 23 E9 02 JSL 02E923 Count them up  
 AF:8D FB EC STA ECFB Store error flag  
 B2:68 PLA  
 B3:68 PLA  
 B4:68 PLA  
 B5:68 PLA  
 B6:68 PLA  
 B7:68 PLA Pull all extra values  
 B8:AD FB EC LDA ECFB Load error flag  
 BB:B0 01 BCS BE (+01) If error then bomb  
 BD:60 RTS Return to caller  
 BE:C2 30 REP #30 16 bit wide Accum.  
 C0:A2 00 00 LDX #0000  
 C3:A9 DB DB LDA #DBDB Load 2 STP's  
 C6:9D 00 00 STA 0000,X Store them everywhere  
 C8:EB INX  
 CA:EB INX  
 CB:D0 F9 BNE C6 (-07)  
 CD:AC EB EC JMP ECEB = BOMB =  
 D0:C2 30 SEP #30 8 bit wide Accum.  
 D2:20 EB 79 JSR 79EB  
 D5:E2 30 REP #30 16 bit wide Accum.  
 D7:60 RTS OKAY to run program!  
 D8:54 4F 4E 59 TONY Disk name/volume

Well that's most of the protection routine, which is the exact same routines (different absolute addresses though) used on the 4th & Inches master disk. After checking this code I found the calls to it look like JSR EC55 (20 55 EB) on the disk. Searching for this sequence revealed two calls to the protection. After changing both JSR's (20) to LDA's (AD), I booted the disk and the program ran just fine. Applying the two disk edits resulted in a cracked working version of 4th & Inches Team Construction disk. The easy step by step method would be:

1. Make a copy of the game disk.
2. Make the following edits to the copy.
 

Blk	Byte(s)	From	To
\$168	\$80	20 55 EC	AD 55 EC
\$190	\$77	20 55 EC	AD 55 EC
3. Write the blocks back to disk.

Store the original in a safe place. Use the copy to work from.

Softkey for...  
**Geometry v1.0**  
*Broderbund*

**Requirements:**  
 512K Apple IIgs  
 3.5" disk copier  
 3.5" disk editor

Geometry is a great educational program from Broderbund/Sensei. They use the standard nibble counting routine on tracks 20/21 like they did for Showoff. To find the copy protection routine search for A2 20 A0 01, then list out the code that follows. Anyway, back tracing the routines twice, you end up with a single call to the routine. How ever, disk 2 would still ask you to insert disk 3 and if either disk/program was upload to a hard disk, they would ask for disk 3. I found the JSL right before the call to the nibble count checks to see if the disk online is called "/DISK3" so I killed that routine too! Now the programs no longer care what disk they are booted from or if it's an original.

1. Make of copies of disk 2 and 3.
2. Make the following edits:

**On disk 2:**

Blk	Byte(s)	From	To
\$408	\$8B	22 00 00 00	AF 00 00 00
	\$93	22 E8 0D 00	AF E8 0D 00

**On disk 3:**

Blk	Byte(s)	From	To
\$E7	\$1C6	22 00 00 00	AF 00 00 00
	\$1CE	22 E8 0D 00	AF E8 0D 00

3. Write the blocks back to the disk.
4. Optional: Upload the programs to your hard disk.

Softkey for...  
**Impossible Mission 2 GS**  
*Epyx*

**Requirements:**  
 512K Apple IIgs  
 3.5" Disk copier  
 3.5" Disk editor

Impossible Mission 2 (IM2) has been released in a Double Hi-res version for 128K apples and a full GS version. This new game is a futuristic continuation of the original Impossible Mission. The object of the game is to search through a multi-level building searching for parts

of puzzle. Of course you must avoid all the robots and jump from platform to platform, all of which makes for good game. To continue, I will explain the protection used on the GS version and I'll show how I went about defeating the routine. First, the game is released by Epyx, so I thought they might be using the old commercial nibble counting routine. Scanning for A2 20 A0 01 reveals the following on block \$4A3 (on the disk):

35:8B PHB  
 36:4B PHK  
 37:AB PLB  
 38:AF 98 59 00 STA 005998  
 3C:48 PHA  
 3D:22 F5 69 00 JSL 0069F5  
 41:FA PLX  
 42:B0 3A BCS 7E (+3A)  
 44:E2 30 SEP #30 ; 8-bit wide Accum & registers  
 46:A2 20 LDX #20 ; Load track number \$20  
 48:A0 01 LDY #01 ; Side  
 4A:20 D7 69 JSR 69D7 ; Go to the nibble count  
 4D:B0 02 BCS 51 (+02) ; Carry set means read errors  
 4F:80 04 BRA 55 (+04) ; Skip over the set fail  
 51:A2 FF LDX #FF ; Load a bad sum in X-reg  
 53:A0 FF LDY #FF ; Load a bad sum in Y-reg  
 55:C2 30 REP #30 ; Switch to 16-bit  
 57:8A TXA ; Transfer hi-byte to Accum  
 58:8F D8 59 00 STA 0059D8 ; Store in a storage area  
 5C:98 TYA ; Transfer lo-byte to Accum  
 5D:8F D9 59 00 STA 0059D9 ; Store in a storage area  
 61:E2 30 SEP #30 ; Switch back to 8-bit  
 63:A2 21 LDX #21 ; Load track number \$21  
 65:A0 01 LDY #01 ; Side  
 67:20 D7 69 JSR 69D7 ; Go to the nibble count  
 6A:B0 02 BCS 6E (+02) ; Carry set means read error  
 6C:80 04 BRA 72 (+04) ; Skip over set fail  
 6E:A2 FF LDX #FF ; Load a bad sum in X-reg  
 70:A0 FF LDY #FF ; Load a bad sum in Y-reg  
 72:C2 30 REP #30 ; Back to 16-bit again  
 74:8A TXA ; Transfer the hi-byte to Accum  
 75:8F DA 59 00 STA 0059DA ; Store in a storage area  
 79:98 TYA ; Transfer the lo-byte to Accum  
 7A:8F DB 59 00 STA 0059DB ; Store in a storage area  
 7E:22 99 6A 00 JSL 006A99  
 82:AB PLB  
 83:6B RTL ; Return to sender  
 84:5A PHY Push side (this is 69D7)  
 85:DA PHX ; Push track number  
 86:F4 00 00 PEA 0000  
 89:F4 F0 69 PEA 69F0 ; Push disk name location  
 8C:22 B6 6A 00 JSL 006AB6 ; Count them up  
 90:8D F4 69 STA 69F4 ; Store the Accum  
 93:68 PLA  
 94:68 PLA  
 95:68 PLA  
 96:68 PLA  
 97:68 PLA  
 98:68 PLA ; Pull extra values off stack  
 99:AD F4 69 LDA 69F4 ; Load the Accum again  
 9C:60 RTS ; Return to caller  
 9D:49 4D 32 00 IM2 ; Disk volume/name  
 A1:00 ; Storage area for 69F4

My first attempt (which works!) was to change the LDX #20 (A2 20) to BRA 51 (80 09) and the change the LDX #FF (A2 FF) to LDX #1F (A2 1F). This way a good value (at least passable) of \$1FFF would be stored in the result location. Then I did a similar trick with the LDX #21 and the following LDX #FF. This works fine by never actually running the nibble count, but storing a passable value in the right locations thus "tricking" the routine into working. However, I decided to stick with my usual methods and do the following two things. First, find the call to the nibble count and disable it there. Second, find the compare routines and force them to continue.

The nibble counting routine is called once from block \$3AE in the form of JSL 004AD8 (22 D8 4A 00). Changing the JSL (22) to a LDA (AF) will kill the call to the nibble counting routine. Now we must find the code that compares the read in values to known values. How do we find those routines? In the above disassembly the results are stored in 59D8 and 59DA. Simply search the disk for a reference to that location. Searching for D8 59 (59D8 in reverse, also I wasn't sure if they loaded it in long (LDA 0059D8 or AF D8 59 00) or short (LDA 59D8 or AD D8 59) mode showed the following section of code on block \$3A6:

0FD:22 A5 18 00 JSL 0018A5 Get a bench mark value (1F50)  
 101:38 SEC Set up for subtraction  
 102:ED D8 59 SBC 59D8 Subtract the read in value  
 105:70 03 BVS 10A (+03) Is it too low?  
 107:49 00 80 EOR #8000 Is it too high?  
 10A:10 08 BPL 114 (+08) It's within the right range  
 10C:A9 01 00 LDA #0001 Load a fail value  
 10F:8D 90 59 STA 5990 Store it in the flag

112:80 03 BRA 117 (+03) Skip over the set pass  
 114:9C 90 59 STZ 5990 Zero = an original  
 117:22 F4 16 00 JSL 0016F4 Continue the game

So once again we find another flag waiting to be captured. If we don't get this flag, every time you try search for something, you're thrown back to title display.

Now this leaves us with the question of how to force the code to continue. Well we have several possibilities when looking at the above section of code. One, you could NOP everything from 105 to 10E and change the STA 5990 (8D 90 59) to STZ 5990 (9C 90 59); the only needed change is the STA to STZ. Two, change the LDA #0001 (A9 01 00) to LDA #0000 (A9 00 00). Three, change the BVS 10A (70 03) to BRA 114 (80 0D), which is what I choose to do.

Well to continue with the crack, do the following:

1. Make a copy of the game disk
2. Make the following edits to the copy only

Blk	Byte(s)	From	To
\$3A6	\$105	70 03	80 0D
\$3AE	\$3A	22 D8 4A 00	AF D8 4A 00

3. Write the blocks back to the disk

Store the original in a safe place. Use the copy to play from.

Softkey for...  
**Jack Nicklaus' 18 Holes of Major Championship Golf**  
*Accolade*

**Requirements:**  
 512K Apple IIgs  
 3.5" disk copier  
 3.5" disk editor

To remove the KEYWORD (Pirate) protection from Jack Nicklaus Golf follow these easy steps:

1. Make a copy of both of the Jack Nicklaus golf disks.
2. Make these edits to the COPY of the "game" disk only, never make any edits to the original!

Blk	Byte(s)	From	To
\$92	\$7F	F0 04	80 04
	\$81	22 BA 03 00	AF BA 03 00

3. Write the block back to the copy

Store the original in a safe place with the manual. Optional: Upload the game to your hard disk. Play a game of Golf!

Softkey for...  
**Kinderama**  
*Unicorn*

**Requirements:**  
 1.25M Apple IIgs  
 3.5" disk copier  
 3.5" disk editor

Sure, right after I make a general comment like: "To crack all Unicorn programs search for A2 21 A0 01 20 and change it to 80 2C A0 01 20", Unicorn changed their protection to a bad block check. Anyway, I found three different cracks for the two disks. I forced the protection routine to pass on three different levels. Each edit on a different block will crack the program by itself (overkill!!) so take your pick or make them all.

1. Make a copy of the two disks.
2. Make the following edits on the copies only.

**On disk 1:**

Blk	Byte(s)	From	To
\$220	\$21	22 5B 33 00	AF 5B 33 00
	\$25	B0 07	80 07
\$224	\$4A	22 CF 2F 00	AF CF 2F 00
\$25C	\$6C	22 48 38 00	AF 48 38 00
	\$77	D0 03	80 0D

**On disk 2:**

Blk	Byte(s)	From	To
\$4E2	\$21	22 5B 33 00	AF 5B 33 00
	\$25	B0 07	80 07
\$4E6	\$4A	22 CF 2F 00	AF CF 2F 00
\$51E	\$6C	22 48 38 00	AF 48 38 00
	\$77	D0 03	80 0D

3. Write the blocks back to the copies

Softkey for...  
**Math Blaster Plus**  
*Davidson*

**Requirements:**  
 512K Apple IIgs  
 3.5" disk copier  
 3.5" disk editor

Math Blaster Plus (MBP), has been released in a GS format and is a very nice educational program. The program is written in a version of Forth and is somewhat hard to follow. There is a routine to a "global" ProDOS 16 link (interface), that is, jump to the routine with the info and the routine modifies itself and makes the call. After much searching I did track it down, then with some help from Leh-Wen Yau I was able to come up with a nice little patch. The first edit kills that

call to the ProDOS 16 link at \$26F. The second patch stores a zero (which means an error from the \$26F routine) in the right place by changing the STA 0034,X to STZ 0034,X. A sneaky edit!

1. Make a copy of the Math Blaster Plus disk (ignore errors).
2. Make the following edits to the copy only.

Blk	Byte(s)	From	To
\$9	\$1BD	20 6F 02	AD 6F 02
	\$1C2	9D 34 00	9E 34 00

3. Write the edits back to disk

Thanks again to Leh-Wen Yau. (Remember: Give credit where credit is due!)

Softkey for...  
**Qix**  
*Taito*

**Requirements:**  
 128K Apple II series  
 5.25" disk copier  
 5.25" sector editor

Warning: This article is written for those who like LONG articles

Qix from Taito is a micro adaption of the old arcade game. While the port over was not awesome, it was better than average (I'm still waiting for the GS version!). Anyway, the program is copy protected and the only way to back it up is to use EDD 4 plus (which I don't own) or crack it (that I can do).

The copy protection (CP) routine first searches for a CP header of D5 CC AA, then stores the following four bytes read from the disk. Then the routine proceeds to find the CP header again and compares the four bytes read to the four bytes stored. The trick is, because the bytes after the CP header have several zero bits in a row (making them invalid), the hardware CANNOT read them reliably. The whole CP routine is based on the fact that the invalid bytes will be read correctly less then 75% of the time! It loops through four times reading the same four invalid bytes after the CP header and increments one of four flags when a byte matches. Then another routine adds up the four flags and compares the value to \$C (12 in decimal). If the four invalid bytes match more than 12 times then the program must be a copy. I will list the code used in the copy protection and comment it to making it easier to understand.

Now your bit copier reads the track once then writes it out to a blank disk. The problem is the bit copier will not reproduce all the extra zero bits so you end up with a non-working copy. Here is one of the control routines:

D19:AE DC 03 LDX 03DC Get slot number IE: 6 for slot six  
 D1C:A0 01 LDY #01 Get drive number  
 D1E:20 05 0A JSR 0A05 Calculate slot/drive & store them  
 D21:20 11 0A JSR 0A11 Go through the cp routines  
 D24:B0 05 BCS 0D2B (+05) Couldn't find CP header or read error  
 D26:20 B9 0A JSR 0AB9 Add flags & compare to \$C  
 D29:90 1D BCC 0D48 (+1D) Less then \$C matches, continue  
 D2B:4C C1 03 JMP 03C1 Wipe memory & reboot

Now here is the actual copy protection routines listed from \$A00 to end:  
 A00-A04 is the data table for slot/drive & CP header.

A00:60 Slot number times 16  
 A01:01 Drive number  
 A02:D5 CC AA Copy protection header

A05 is the entry point to calculate the slot & drive and store routine.

A05:8A TXA Transfer X to A  
 A06:0A ASL Multiply by 2  
 A07:0A ASL Multiply by 2  
 A08:0A ASL Multiply by 2  
 A09:0A ASL Multiply by 2 (times 16 overall)  
 A0A:8D 00 0A STA 0A00 Store in slot number  
 A0D:8C 01 0A STY 0A01 Store in drive number  
 A10:60 RTS Return to caller

A11 is the disk read entry point and called from the game.

A11:A5 FE LDA FE  
 A13:A6 FF LDX FF  
 A15:85 FE STA FE  
 A17:86 FF STX FF  
 A19:AD 00 0A LDA 0A00 Load Slot number \* 16  
 A1C:8D B4 0B STA 0BB4 Store it  
 A1F:4A LSR Divide by 2  
 A20:4A LSR Divide by 2  
 A21:4A LSR Divide by 2  
 A22:4A LSR Divide by 2 (from \$60 to \$06)  
 A23:09 C0 ORA #C0 Make it into \$Cx (or \$C6 for slot 6)  
 A25:85 FF STA FF Store it at FF  
 A27:AD 01 0A LDA 0A01 Load drive number  
 A2A:8D B5 0B STA 0BB5 Store it  
 A2D:A9 00 LDA #00 Load zero  
 A2F:85 FE STA FE Store at FE (FE=00 C6)  
 A31:A2 05 LDX #05 We need to use six bytes  
 A33:BC B3 0A LDY 0AB3,X Load from "check slot" data table

A36:B1 FE LDA (FE),Y Load indirect+index, C600+Y

A38:CA DEX Decrement index

A39:DD B3 0A CMP 0AB3,X Compare to KNOWN value for 5.25" interface

A3C:D0 3A BNE 0A78 (+3A) If NOT EQUAL, then try different slot

A3E:CA DEX Decrement index

A3F:10 F2 BPL 0A33 (-0E) Did we use all 6 bytes (X=\$FF)

A41:A0 FF LDY #FF Load Y with FF manually

A43:B1 FE LDA (FE),Y Check C6FF

A45:F0 4B BEQ 0A92 (+4B) If it's zero then it's a 5.25" interface

A47:C9 FF CMP #FF Check to see if it's equal to \$FF

A49:F0 2D BEQ 0A78 (+2D) If it is, then try another slot

A4B:69 03 ADC #03 Add 3 for "smartport" interface

A4D:85 FE STA FE Store value from CxFF+3 in FE

A4F:AD 01 0A LDA 0A01 Load drive number

A52:8D AF 0A STA 0AAF Store it

A55:A2 21 LDX #21

A57:90 07 BCC 0A60 (+07)

A59:A9 01 LDA #01

A5B:8D AF 0A STA 0AAF

A5E:D0 0D BNE 0A6D (+0D)

A60:AD AB 0B LDA 0BAB

A63:C9 01 CMP #01

A65:D0 06 BNE 0A6D (+06)

A67:AD AC 0B LDA 0BAC

A6A:F0 3E BEQ 0AAA (+3E)

A6C:38 SEC

A6D:AD AF 0A LDA 0AAF

A70:8D B5 0B STA 0BB5

A73:CD 01 0A CMP 0A01

A76:D0 DD BNE 0A55 (-23)

A78:AD B4 0B LDA 0BB4 Load slot number \* 16

A7B:38 SEC Get ready for subtraction

A7C:E9 10 SBC #10 Subtract \$10 (\$60 - \$10 = \$50)

A7E:B0 02 BCS A82 (+02) CARRY SET unless \$00 goes to \$F0

A80:A9 70 LDA #70 Load \$70 for slot 7

Subtract \$10 from slot until it goes from \$00 to \$F0, then load \$70 for slot 7. If you don't find a match (\$70-\$10 becomes \$60) or the value stored at \$A00, then with the CARRY SET, fall through to the return section of code. CARRY SET means had an error of some sort like: an I/O error (read error), couldn't find CP header, or couldn't find a 5.25" disk drive interface.

A82:CD 00 0A CMP 0A00 Compare to current slot

A85:D0 95 BNE 0A1C (-6B) Not equal then go back and try again

A87:AD B6 0B LDA 0BB6 This is how we get back from a JSR 0A11

A8A:85 FE STA FE BB6, BB7, FE, FF not used in the actual program, but stored for the second call

A8C:AD B7 0B LDA 0BB7 to this routine.

A8F:85 FF STA FF Return to caller, CARRY CLEAR = good read

A91:60 RTS

A92:AD B5 0B LDA 0BB5 Load drive number

A95:C9 03 CMP #03 Check to see if it's larger than 3

A97:90 05 BCC 0A9E (+05) No, it's 1 or 2 then branch

A99:A9 01 LDA #01 Otherwise load 1 for drive one

A9B:8D B5 0B STA 0BB5 and store it in drive number

A9E:20 C9 0A JSR 0AC9 Do the actual CP routine

AA1:90 E4 BCC 0A87 (-1C) Carry clear = found CP header, goto return

AA3:20 C9 0A JSR 0AC9 Try again, might have missed it the 1st time

AA6:90 DF BCC 0A87 (-21) Carry clear = found CP header, goto return

AA8:B0 CE BCS 0A78 (-32) Couldn't find header, try another drive

AAA:38 SEC Set the CARRY flag

AAB:B0 C0 BCS 0A6D (-40) Branch on CARRY set (always taken)

AAD:60 03 00 Data, not sure for what though

AB0:C3 22 03 Data, again not sure for what

AB3:03 05 00 03 20 01 Data table for "check slot"

On most disk drive interfaces, where x=slot: Cx01=20, Cx03=00 and Cx05=03. CxFF is the address of the "dispatch" routine for ProDOS devices like 3.5" drives, SCSI drives, etc. Cx07 is the byte used to tell the difference between the types of drives (5.25" or 3.5" and SCSI). CxFB will tell if the drive can handle extended and/or SCSI calls. AB9 is the entry point for "add the flags & compare against \$C" routine. This routine is called from game and not from within the CP routines.

AB9:AD B0 0B LDA 0BB0 Load read-match-flag-1

ABC:18 CLC Set up for addition

ABD:6D B1 0B ADC 0BB1 Add read-match-flag-2

AC0:6D B2 0B ADC 0BB2 Add read-match-flag-3

AC3:6D B3 0B ADC 0BB3 Add read-match-flag-4

AC6:C9 0C CMP #0C Compare to \$C, CARRY CLEAR is less than

AC8:60 RTS Return to caller

AC9 is the entry point the actually turns on the

drive and starts to read for CP header and invalid bytes, called only within the CP routines

AC9:AE B4 0B LDX 0BB4 Load slot number times 16

ACC:AD B5 0B LDA 0BB5 Load drive number

ACF:18 CLC Ready for an addition

AD0:6D B4 0B ADC 0BB4 Add slot times 16

AD3:A8 TAY Y=Slot+Drive

AD4:B9 89 C0 LDA C089,Y Select the drive

AD7:BD 89 C0 LDA C089,X Turn on the drive

ADA:A0 00 LDY #00 Load Y-reg with zero

ADC:8C A5 0B STY 0BA5 Store in loop counter

ADF:20 73 0B JSR 0B73 JSR to an RTS to let the drive come up

AE2:CE A5 0B DEC 0BA5 to full speed. Loop through 255 times

AE5:D0 F8 BNE 0ADF (-08) Did we finish the loop?

AE7:88 DEY

AE8:F0 15 BEQ 0AFF (+15)

AEA:BD 8C C0 LDA C08C,X Load some bits from the drive

AED:DD 8C C0 CMP C08C,X Compare to another read

AF0:F0 F5 BEQ 0AE7 (-0B) If they match, the drive is not moving

AF2:A9 28 LDA #28 Load \$28

AF4:8D A5 0B STA 0BA5 Store it in the "find header loop", we should find the CP header in \$2828 disk bytes

AF7:8D A6 0B STA 0BA6 Routine to find the header

AFA:20 74 0B JSR 0B74 Carry set means we found the CP header

AFD:B0 03 BCS 0B02 (+03) At B6F, set carry & turn off drive (failed)

AFF:4C 6F 0B JMP 0B6F Routine to read a byte off the disk

B05:8D A7 0B STA 0BA7 Store it in "first-read-1"

B08:A9 00 LDA #00 Load zero to initialize "read-match-flag"

B0A:8D B0 0B STA 0BB0 Store in read-match-flag-1

B0D:20 9F 0B JSR 0B9F Get a disk byte

B10:8D A8 0B STA 0BA8 Store in first-read-2

B13:A9 00 LDA #00

B15:8D B1 0B STA 0BB1 Initialize read-match-flag-2

B18:20 9F 0B JSR 0B9F Get a disk byte

B18:8D A9 0B STA 0BA9 Store in first-read-3

B1E:A9 00 LDA #00

B20:8D B2 0B STA 0BB2 Initialize read-match-flag-3

B23:20 9F 0B JSR 0B9F Get a disk byte

B26:8D AA 0B STA 0BAA Store in first-read-4

B29:A9 00 LDA #00

B2B:8D B3 0B STA 0BB3 Initialize read-match-flag-4

B2E:A0 04 LDY #04 Set up to loop through four times

B30:A9 00 LDA #00

B32:8D A5 0B STA 0BA5 Set up to find the CP header somewhere in the next \$FFFF disk bytes

B35:8D A6 0B STA 0BA6 Find CP header

B38:20 74 0B JSR 0B74 Get a disk byte

B3B:20 9F 0B JSR 0B9F Get a disk byte

B3E:CD A7 0B CMP 0BA7 Compare to first-read-1

B41:D0 03 BNE 0B46 (+03) Do the match?

B43:EE B0 0B INC 0BB0 If yes, inc read-match-flag-1

B46:20 9F 0B JSR 0B9F Get a disk byte

B49:CD A8 0B CMP 0BA8 Compare to first-read-2

B4C:D0 03 BNE 0B51 (+03) Do they match?

B4E:EE B1 0B INC 0BB1 If yes, inc read-match-flag-2

B51:20 9F 0B JSR 0B9F Get a disk byte

B54:CD A9 0B CMP 0BA9 Compare to first-read-3

B57:D0 03 BNE 0B5C (+03) Do they match?

B59:EE B2 0B INC 0BB2 If yes, inc read-match-flag-3

B5C:20 9F 0B JSR 0B9F Get a disk byte

B5F:CD AA 0B CMP 0BAA Compare to first-read-4

B62:D0 03 BNE 0B67 (+03) Do they match?

B64:EE B3 0B INC 0BB3 If yes, inc read-match-flag-4

B67:88 DEY Decrement the number of loops

B68:D0 C6 BNE 0B30 (-3A) Continue if loop number not equal to zero

B6A:BD 88 C0 LDA C088,X Turn the drive off

B6D:18 CLC Clear carry = pass (found Cp header & bytes)

B6E:24 Used to make the following byte into BIT 38

B6F:38 SEC Set carry = fail (didn't find CP header)

B70:BD 88 C0 LDA C088,X Turn the drive off

B73:60 RTS Return to caller

B74 is the entry point to read for the CP header, called within CP routines.

B74:BD 8C C0 LDA C08C,X Read for a byte

B77:10 FB BPL 0B74 (-05) Loop until the high bit is set

B79:CE A5 0B DEC 0BA5 Dec disk bytes to read through (low order)

B7C:D0 05 BNE 0BA6 (+05) Did we flip through the low order?

B7E:CE A6 0B DEC 0BA6 Then dec the high order byte

B81:F0 1A BEQ 0B9D (+1A) If we flipped through high, then error out

B83:CD 02 0A CMP 0A02 Compare to first CP header byte (D5)

B86:D0 EC BNE 0B74 (-14)

B88:BD 8C C0 LDA C08C,X Get next byte

B8B:10 FB BPL 0B88 (-05)

B8D:CD 03 0A CMP 0A03 Compare to second CP header byte (CC)

B90:D0 F1 BNE 0B83 (-0F)

B92:BD 8C C0 LDA C08C,X Get next byte

B95:10 FB BPL 0B92 (-05)

B97:CD 04 0A CMP 0A04 Compare to third CP header byte (AA)

B9A:D0 E7 BNE 0B83 (-19)

B9C:60 RTS Return to caller

B9D:18 CLC Carry clear means couldn't find CP header

B9E:60 RTS Return to caller

B9F:BD 8C C0 LDA C08C,X Read disk bits

BA2:10 FB BPL 0B9F (-05) Wait until the high bit is set

BA4:60 RTS Return

BA5-BB7 is the data table for various things.

BA5:FF FF Number of disk bytes to read through

BA7:FF FF FF FF First-read 1 through 4

BAB:FF FF FF FF FF Read-match-flags 1 through 4

BB0:FF FF FF FF First choice slot & drive

BB4:FF FF Actual slot & drive

When looking at the control section, I decided to change the JSR 0A11 (20 11 0A) to CLC, BCC 0D48 (18 90 24) to always branch to the continue section without ever running the CP routines. I also found another call to 0A11 and calculated the correct branch on a pass and replaced it to.

Note: You could simply change the JSR 0A11 to NOP NOP CLC (EA EA 18), however then you MUST change the flag values (like I did) or kill the call to the flag check. The last thing I did was to make sure we don't find any hidden bombs later in the game. To do this, I found the four flags on the disk and changed them to values that would pass when added together. This is very important on other Taito release like Arkanoid GS, Arkanoid 2 GS, and Renegade IIe. After the second call to the CP routine is made and it passes, the routine is overwritten with game code.

1. Make a copy of the Qix game disk.

2. Make the following edits to the copy only:

Trk	Sec	Byte(s)	From	To
\$00	\$0D	\$B0	FF FF FF FF	01 01 01 01
	\$0E	\$38	20 11 0A	18 90 03
	\$0F	\$21	20 11 0A	18 90 24

3. Write the sectors back to the copy.

Store the original & play off the deprotected copy.

Advanced Playing Technique for...  
**Qix**  
Taito

The number of men are stored at \$A5C, so for a never ending game change track \$1E, sector \$4, bytes \$2F-\$31 from CE 5C 0A (DEC 0A5C) to EA EA EA.

While the game will not allow more than 5 men, you can start with 5 men by changing the A9 03 8D 5C 0A (TRK \$1B, SCT \$0, byte \$49) to A9 04 8D 5C 0A. The game counts your men from man zero to whatever. Then, when your man zero dies, the men flag goes to \$FF and is checked to see if the high bit is set. When set (values of \$80 to \$FF), a BMI (Branch on MInus) instruction is taken and the game is over.

Softkey for...  
**Renegade**  
Taito

Requirements:  
128K Apple II series  
5.25" disk copier  
5.25" sector editor

Renegade is nice conversion from the arcade game to Double Hi-res Apple II graphics. The game is copy protected just like Qix (also by Taito) with minor adjustments. The major difference in the copy protections are: First, if you do not set the flags (see the Qix article), the program messes up the shape table and the game will be unplayable. Second, Renegade is written under ProDOS 8. Third, and most important, Renegade use a KEYDISK system. In fact, the is the FIRST Apple IIe that I can think of that uses a keydisk.

Most of the time, when a copy protection routine fails, the program will just hang or reboot. With Renegade, you are allowed to insert the original in any drive! The best thing about this protection (other than it's about to be removed!) is the game is hard disk compatible.

1. Make a copy of both sides of the Renegade game disk

2. Make the following edits on side 1 of the copy

Trk	Sec	Byte(s)	From	To
\$05	\$08	\$B9	0C 07 03 09	01 01 01 01
	\$0B	\$BD	20 62 28	18 90 2D

3. Write the sectors back to the copy

4. Rename LOAD.SYSTEM to RENEGADE.SYSTEM

To upload to a hard drive (RAM drive, 3.5", etc), make a subdirectory, you can call it anything you like, but RENEGADE is a good choice. Now copy all the files except PRODOS into the new subdirectory from both sides of the deprotected game disk. You don't have to recopy a couple of the duplicate files on the back side, they are there so you don't have to flip the disk for every scene. Now you see why I renamed the system file, so you can easily tell which file to run to start Renegade. For an indepth study of the basis, theory, and ideas behind the copy protection used on Renegade, please read the Qix article.

Softkey for...  
**Silpheed**  
Sierra

Requirements:  
512K Apple IIGs  
3.5" disk copier  
3.5" disk editor

Silpheed is a nice arcade shoot-em-up from Sierra. The only real problem I found was that before you can play a game you must identify an enemy ship. Which is, of course, Keyword (pirate) protection. To remove it make the following edits:

1. Make copies of both Silpheed game disks
2. Make the following edits to a copy of disk one only

Blk	Byte(s)	From	To
\$1AA	\$126	22 00 00 00	AF 00 00 00
	\$12A	AD 00 00	EE 00 00
	\$12D	D0 03	80 03

3. Write the edits back to the copy.
4. Optional: Upload the game to your hard drive!

Softkey for...  
**Sporting News Baseball**  
Epyx

Requirements:  
128K Apple II series  
5.25" disk copier  
5.25" sector editor

Sporting News Baseball (SNB) from Epyx is a nice baseball game in double Hi-res on 128K Apple II series. Epyx is using the PROLOK copy protection scheme as on many other releases by Epyx and other companies. The routine has been well explained in previous issues of COMPUTIST, however, here is a quick run down.

First on track \$00 there is a string of E7s. Each E7 has one or two added zero bits attached to it. When your disk controller card reads these bytes the added zero bits are ignored. Then upon bootup of SNB, a routine scans for the E7s, then in the middle of reading a byte, the routine clears the data latch and starts reading a new byte. Because the bits are no longer in sync with the E7 pattern, the added zeros becomes part of the new bytes read in. Then by comparing these "new" bytes to a list of expected read bytes, you can tell if the zero bits are present. By using this indirect method of checking, PROLOK (the scheme) can determine if the original disk is in the drive. Then to complicate things, the routine uses these bytes as keys in decrypting the RWTS that is used to load the game.

Now your bit copiers have a hard time telling the difference between a single or dual added zero bits. Most of the time, without special parameters, bit copy programs will not make an accurate back up. EDD 4 has a special parameter in the pre-analyze routine that searches for the E7s in memory and will add the zero bits when copy is being written. So to make a deprotected copy follow these steps:

1. Make a copy of both sides of The Sporting News Baseball
2. On a copy of side one make the following edits:

Trk	Sec	Byte(s)	From	To
\$00	\$01	\$4E	A2 07 8A 95 F0	A9 FC 85 F0 85
			CA 10 FA A6 2B	F3 85 F6 A9 EE
				BD 89 C0 BD 8E
	85	F1 85 F2 85		
			C0 A9 0B 85 F0	F5 A9
	E7	85 F4		
			C6 F0 D0 0B EE	85 F7
				18 90 6E

3. Write the sector back to the copy.

What the edit does is to store the right sequence of bytes in \$F0 through \$F7, then clears the carry and branches down to the section that decodes the rest of loader/RWTS. The patch is only twenty-five bytes long and except for maybe the exact same offset in the branch may be used on other programs that use this scheme. The code looks like this disassembled:

A9 FC	LDA #FC	Load FC
85 F0	STA F0	
85 F3	STA F3	
85 F6	STA F6	Store it in F0, F3 & F6
A9 EE	LDA #EE	Load EE
85 F1	STA F1	
85 F2	STA F2	
85 F5	STA F5	Store it in F1, F2, & F5
A9 E7	LDA #E7	Load E7
85 F4	STA F4	
85 F7	STA F7	Store it in F4 & F7





2. The EASIEST and FASTEST way to correct (fix) any disk (including hard drives) is to use Procel's Mr. Fixit, Quality Software's Bag of Trix 2, or any other disk utility that can check and correct parent pointers. Both of the above mentioned programs have been tested and work fine.

3. The third, and probably the most difficult, is to use Copy II Plus's sort routine and put the directories back in their original sequence. Did you write down or print out the catalog before reorganizing or do you have a photographic memory, no? If you can't use step 2, hopefully the disk is bootable and you can use step 1.

Final notes: This problem will usually never appear for most people, since it requires that GS/OS be launched after Bird's Better Bye has been run. If you REBOOT GS/OS or use any other program launcher/selector exclusively, then you'll probably never know that Copy II Plus's ver 9.0 sort routine has not updated your directory parent pointers and everything will work fine (unless your application specifically looks at them; and most don't).

To Rich Linville: Use AMDOS if you need DOS 3.3 on a 3.5" disk.

To Ann Onymous: I can transfer IBM files to Apple DOS, so go ahead and send your material to COMPUTIST on IBM disks.

## The Dark Phoenix UT

Well, to put it plain and simple, after receiving issue #66 I was shocked! I would never have guessed that a magazine as good as COMPUTIST only had about 4000 subscribers, so that means that about 3,000 are faithful renewers, that's puzzling.

Now that I'm done kissing up, I can tell you what I propose. I like to think of it as taking the ice cream and cake in one bite. As much as a hate to say this, I believe that the first step is going to the tabloid format, I personally HATE the tabloid format, but its cost-effective. Second, I would go to a two-week publication rate (gradually) and have subscription renewals at 6-12 months. Then I would raise the price \$1. That's not so bad and you would probably only lose about 50 subscribers. Then I would see what I could do about getting in book stores and computer stores (hardware of course) and supermarkets. I never even heard of such a magazine until a friend told me about it! Which goes to show you how hard it is to find COMPUTIST. Fourth, (IF NEEDED!) do away with the mac section all together and make more room for editors comments, reviews, etc. Look at InCider, that's all it is and it has a HUGE subscriber list.

If you can avoid it at all, please don't keep going on the tabloid format, its so annoying, not to mention unprofessional looking.

I liked your idea of giving brownie points to all people who bring new subscribers, but I also think that it would be a good idea to have a raffle every three months for a piece of hardware (modems, hard drives, memory cards, enhancements, etc.) and every new subscriber you bring in you get one entry ticked into the raffle, the result = the more new subscribers you get, the better chance you have of winning! or you could do a 1\$ an entry raffle, non profit of course, and make it open ONLY to subscribers, that would be a catch that sure to bring in 400-500 new ones each year.

The fact that COMPUTIST remains unadvertised is a fault that is loosing COMPUTIST thousands of subscribers. If COMPUTIST were to just send fliers around, to the many who have accidentally destroyed originals, they would have many a new subscriber.

I also believe that if COMPUTIST got more in-depth on HOW to find a sector error and correct it, there would be many new subscribers, because beginners are interested in HOW not WHAT to do! (take it from a professional beginner). I believe that a contest, to see who can explain this would be the best way to pursue this! Have a most wanted (speaking of which, if anyone knows the softkey to Deathlord, I need it badly, my original is getting trashed) softkey, and a contest on who can de-protect it, not only the fastest, but the most in-depth. have the beginner readers write in and cast their votes.

## Carl D. Purdy MT

First let me say that I enjoy and look forward to each and every issue of Computist each month or every six weeks now. Enclosed please find my subscription to the Computist Club. I think that is a GREAT idea. I know that I have questions that could be answered on a board much faster than in the mag at times. Keep up the good work.

I would like you to place some things on the Most Wanted List. They are Where in the World is Carmen Sandiego. I know that there is a softkey in an earlier issue but it doesn't work on all of my computers. The keyed program will boot and run on my oldest Iie (with mother board A) but will not boot and run on my newer Iie (mother board B) nor will it run on a Laser 128. Could someone out there help me. Another program I would like to unlock or otherwise back up is Keyboarding Klass by Mastery Development. It is on a PRO-DOS like disk called PAJDOS. I can get a catalogable disk (from PRODOS) but none of the files will run. Finally I would like a softkey for Gertrude's Puzzles.

Ⓢ If any one out there knows why that a program backed up with Wild Card will not run on a Laser 128 please help!

## Ron Powers WI

Ⓢ For Edward Teach (or others): I am having trouble cracking 2 programs. One is Design Your Own Home:Landscape, by Abracadata. I have tried all procedures listed for this one in past issues, but none will even copy my version of the disk. The other program is Success With Reading, by Scholastic.

Ⓢ My other question regards a graphics program called Super Print!, by Scholastic. Thanks to Computist, I have successfully cracked this one. The program allows the printing of graphics in several sizes. However, the 5 ft. tall graphics are separated into a file called "Posters." The problem is that there is a very limited supply of these large-sized graphics with the program. Is there anyone out there who knows how to convert the regular-sized graphics into poster (super) sized?

Here are three softkeys that I was able to perform with the help of past articles dealing with these same publishers:

Softkey for...

### Boppie's Great Word Chase

DLM

#### Requirements:

A way to reset into the monitor  
Super IOB 1.5 with Newswap Controllor

1. Capture the program's RWTS
2. Install the Newswap Controllor and run Super IOB
3. A fast DOS may be installed

Softkey for...

### Surveys Unlimited

Learning Well

1. Poke out end checks and use COPYA to copy the disk.
- POKE 47426,24  
RUN COPYA
2. Transfer files to a DOS 3.3 or Fast DOS disk.

Softkey for...

### Campaign Math

Mindscape

I followed Jack Moravetz's softkey for Ace Reporter, on p. 19 of COMPUTIST #64:

1. Copy with any copier that ignores errors.
2. Make the following sector edit:

Trk	Sec	Byte(s)	From	To
\$01	\$01	\$00	A2	80

## Keith WA

Softkey for...

### Superprint v1.2

Scholastic

#### Requirements:

Apple IIGs with 2.x ROM upgrade  
Two ProDOS formatted disks  
BASIC.SYSTEM from a ProDOS master disk  
Copy II Plus or any ProDOS file copier

Although Superprint has been cracked in several previous articles, the version I have was not readable by COPYA. When I booted the original disk, the ProDOS credits were displayed, so I decided to catalog the disk and see what the files were. However, when I tried to catalog with CopyII Plus, the program gave me "error reading track 11," an error that one usually gets from DOS disks, not ProDOS disks. This would mean that the program when it first boots (track 0) fools Copy II plus into thinking that it runs under DOS rather than ProDOS. Another way to say this is that Scholastic has used a short DOS-like program to boot the disk, then loads ProDOS and the catalog directory. Since they are not in the normal places on the disk, Copy II Plus doesn't see them.

The one other clue I had was that I made a backup using the autocopy feature and Superprint parameters on Copy II Plus v8.3. Although this made a working copy, I got a few that did not work. The program would boot, then reboot almost immediately, and continued to do this endlessly. All this occurred before the ProDOS screen appeared. This meant that a signature check was being done, and that it appeared before the ProDOS was loaded.

With all these assumptions, I set out to crack the protection. I decided to try the system used by Dan Halfwit for Pirates and Pirates GS that appeared in Computist 61 (an excellent pair of articles). After setting "visit monitor", I booted the original Superprint disk, and quickly went to monitor. This allowed their DOS startup to load and run the signature check. I then scanned for the Jump to \$2000 that had been loaded, and replaced it with a jump to monitor. This gives you a stopping point in the program before it begins to run ProDOS, since the beginning point of ProDOS is always at \$2000. I then left the moni-

tor, let the rest of ProDOS load, and then the program jumped back into the monitor because of the stop I had placed above. I then loaded BASIC.SYSTEM as described below (BASIC.SYSTEM will be renamed SP.SYSTEM, but for this discussion I will continue to call it BASIC.SYSTEM). With ProDOS and BASIC.SYSTEM in place, you should now be able to catalog the original Superprint disk. The catalog directory was loaded with ProDOS, and when you are all done, if you look at the Superprint files, you will see one called "disk.info". This contains the directory information.

To copy the files, I next loaded Copy II Plus using the ProDOS smart command. This is done using -UTIL.SYSTEM. This gives you the familiar Copy II Plus menu and you use the "copy files" to copy ALL the files, including ProDOS. You can copy from drive 1 to 2, from 5.25 to 3.5, or from 5.25 to RAM (slot 5, drive 2 on CopyII plus), then later from RAM to a 5.25 or 3.5 disk. Using the RAM is useful if you only have a single 5.25 disk drive, but you have to know how to go into the control panel and set your RAM. (To do this, go to the control panel OA-CNTL-ESC, select RAM DISK, and set the maximum ram to 832K, and leave the minimum to 0K.)

I did not need to do any block edits like Dan Halfwit did, because the protection on this disk is part of the DOS load program, and the above system doesn't copy the jump to the protection system.

#### Cookbook

1. Format in ProDOS both your blank disks using CopyII Plus, and use the volume name SUPER.PRINT. Put one copy aside. With the other one, use CopyII Plus File Copy to copy BASIC.SYSTEM to the disk. When this is completed, then go to the RENAME feature on CopyII Plus, and rename the volume to SP.SYSTEM. Label this disk to distinguish it from the one without SP.SYSTEM. You can find a copy of BASIC.SYSTEM on your ProDOS users disk, and on a lot of software programs. I have made a special disk which has the current version of ProDOS and of BASIC.SYSTEM on it, so that they are easily available to file copy onto my disks.

2. Now set up your IIGS. To get into the monitor, boot up the computer (you don't need a disk in place), then hit OA-CNTL-ESC once or twice fairly soon after the startup, and you will see the Basic prompt. If you miss, try again since this always works. Then type CALL -151, which takes you to the monitor, type a # sign, and hit RETURN. This installs the visit monitor CDA. Now put your Superprint original into the disk drive (be safe and have it write-protected).

Type in C600G at the monitor prompt to boot the disk. Very shortly after the disk starts (one or two clicks), press OA-CNTL-ESC and this will take you to the control panel. This step is one place where errors can occur. If you do it too soon, then the DOS boot and signature check don't get done. If you do it too late, too much ProDOS gets loaded and the program runs. This is not a fatal error, it just means that you may have to try this step several times. Once the ProDOS screen appears on your computer, you know that you are too late. You can tell if you are too early in a subsequent step that I'll mention. If you have to retry, just reboot with OA-CTRL-RESET, rather than go back to the monitor and typing C600G.

3. You are now at a menu. Select Visit Monitor, and hit return. You will see the monitor prompt. You now need to scan for the bytes which tell the program to jump to ProDOS (JMP 2000, which is 4C 00 20). Enter ^C 00 20<800.1FFFP and hit RETURN. On the screen you will see 00/08FC. This is the location that the string starts at. If you type 08FCL then hit RETURN, you will get a listing of the bytes. At 08FC you should see 4C 00 20. (Note that the reason you did the scan is to find the location. You might have something different than 08FC, and should use whatever your scan gives you). Replace the 4C 00 20 with 4C 69 FF which will cause it to jump to the monitor rather than ProDOS. To make the replacement, type 08FC:4C 69 FF, then hit RETURN. Now hit CNTL-Y and RETURN. The program will go a little further, then a monitor sign will appear. What it is doing is finishing the loading of ProDOS and the directory file, then it wants to jump to ProDOS to run the program, but instead jumps to the monitor because of the bytes we changed.

4. You now have the ProDOS and directory loaded. To be able to catalog and load CopyII Plus, you need to load the BASIC.SYSTEM. When ProDOS runs, it will load the first file whose name has .SYSTEM. At this point take out your Superprint original, and insert the ProDOS disk you made that has BASIC.SYSTEM on it (you renamed it to SP.SYSTEM). Type 2000G which will start the program running at ProDOS. This will load the BASIC.SYSTEM, and shortly thereafter you will see the basic prompt ]

5. At this point you get to see if you did everything right. Take the disk out and insert the Superprint original. Type CATALOG, hit RETURN and you should see a list of files scroll by. If this works, then smile. If not, then you need to go back to step 2, where you boot the Superprint disk (you do not need to do the # again).

6. Now you load CopyII Plus. Put your Cop-

pyII Plus disk in the drive, type -UTIL.SYSTEM, hit RETURN. This loads the program, and you will see the familiar CopyII Plus menu. Take out the disk, and insert your Superprint original. Select COPY, then FILES. The source is Slot 6, Drive 1. The target is Slot 6, Drive 1 or Slot 5, Drive 2, if you only have one 5.25 drive (I prefer that latter, which copies to the RAM as discussed above). It is easier for the beginner to copy to Slot 6, Drive 2 if they have two 5.25 drives, or use Slot 5, Drive 1 to copy it to a 3.5 drive (you can always copy from the 3.5 to 5.25 later if you want). At this point all the Superprint files should be visible. Select all the files. You will see the first file highlighted. Hit the RETURN key and the number 1 appears next to it. Hit the arrow key to go down to the next file, hit RETURN and the number 2 appears next to the second file. Repeat this until all the files are selected. At this point the Superprint original should be in the source drive. The second ProDOS disk that you formatted with and named SUPER.PRINT should be in the target drive (this disk is the one that does not have BASIC.SYSTEM on it). Type G, and the copying should begin. Go have a cup of coffee, since this part takes a few minutes.

7. When the copying is done, you should now have a working copy. The protection is removed. CopyII Plus can catalog it, and make copies using the regular disk fast copy procedure. Put your original in a safe place.

8. The back side of the original, and both sides of the other disks can be copied using CopyII Plus and the disk copy program. They are not protected.

Ⓢ Issue 65 contained several excellent articles on converting the ProDOS word processor files to DOS. How about putting these articles on a disk for new subscribers, so they will find it easier to make contributions.

*It really isn't necessary to convert ProDOS word processor files to a DOS format. Just send what you have and write on the disk what program you used. We'll do the conversion here. .... RDEXed*

Ⓢ I am impressed when articles contain long printouts of code that are annotated. How can I capture code the same way for my articles? I'd hate to have to type it all manually.

Ⓢ To Ed Teach, Brian Troha, or one of you other great hackers; How about an article on COPYA and what types of protection are used to keep it from reading a disk. Many of the new disks cause the "unable to read" error to appear when using COPYA, even when DOS is altered to ignore errors, including prologs, etc. What is done to make the disk unreadable, and what changes can be made to make it readable.

Enclosed is my membership for the Computist Club. I like the idea for giving people a chance to win free software. The thing I don't like is that I will have to wait longer between each issue. For those of us who live by a sense of order, perhaps you can publish a list of anticipated mailing dates so that we can know generally when to expect the newsletter (give or take a few weeks <grin>).

Also for those of us who send in a disk, getting back a Computist disk is not always that attractive. Perhaps an alternative would be to include Public domain software or Shareware. You could list disks in the magazine or just surprise us (I think a choice would be nicer). Things which could be included are the monthly disk from Applelink, or things such as fonts, games, and graphics. For members who do not have a modem, they could find this attractive, and you could get the software without much expense. If you need help finding stuff, let me know.

I also have a question regarding the proposed Computist bulletin board. The idea is a good one, but it should take the costs of telephone connections into consideration. Would it be less costly to work through Genie or Applelink or Compuserve? If these phone costs are too high, then the members will not use the bulletin board very much.

In regards to your advertising, I had seen it several times before finally taking a fling. I thought the newsletter was a fly-by-night thing that either would not last, or would be too hard to use. Your ads need to emphasize ease of use, how long you have existed (I was surprised when I joined), and perhaps list the names of some recent deprotects that have been published of "big hits." You might even include a free single subscription to people to let them see how good the newsletter is.

Softkey for...

### Magic Spells

Learning Company

I was having a devil of a time as I had tried all of the softkeys in Computist without success. It turns out that the softkey is really quite simple. Back up the disk with Advanced COPYA, then get into PRODOS. Load the Startup program. Eliminate the two CALLs from the ends of lines 45 and 61. That is all there is to it. This is another bit of help that I received from a friend, Otis Thompson down in Dillon, Montana.

## Stephen M. Caraco MA

Ⓢ I need help copying Arkanoid by Taito. The very first thing I do when I get a new game

(before I even THINK of playing it) is to catalog the disk to get an idea of what types of files are on it, the operating system, how much of the disk is full, etc. The next thing I do is to just make a straight copy of the disk, and boot it up, waiting very impatiently for the disk to crash. If it boots fine, I know I've saved hours of work. If it doesn't, I try to figure out the method of protection. Well, I've come across a tough protection scheme—this one is by Taito Software. The disk is Arkanoid.

When I first booted the copy, it seemed to boot fine. Then, it asked me to insert a key disk and press any key to continue. Although I know in my subconscious that it would never work, I tried pressing return a few times hoping that the program will give up asking after a few times. What did I have to lose? My patience. This is where it all began.

The next thing I did was to break out my Copy II Plus, version 8.4. I was shocked to very easily find the text "PLEASE INSERT THE ARKANOID KEY DISK INTO A DRIVE AND PRESS A KEY" using the sector editor and searching for text. This text can be found spread out over blocks \$024A and \$024B. With other games, such as BUBBLE GHOST (whose key text is "WHAT LEVEL IS THIS?"), searching for the key text is impossible. So this is where I continued to work on the disk.

Since I am not as familiar with copy protection as some people seem to be, I am now lost. I did try NOPping out some of the jumps on that track, and changing a few 80's to F0's at random, but nothing seems to work. I've changed various things, one at a time, and nothing works. Just before I gave up, I found the text NOTICE: (which appears in the box that asks you to insert the key disk) on block \$0249. I found a jump (20 1C 11) immediately before this, and NOPped it out, and all this seemed to do was keep the text from appearing in the box. However, the program still crashed, beeped, and I couldn't play the game!

I do know enough about copy protection to know that there is only a simple byte change that will disable the key disk check on the ARKANOID game. I just can't seem to find it! Perhaps I am looking in the wrong place....

With this, I looked through each block of the entire disk, one at a time. As I approached blocks \$0291-\$0292, I came across the text ...BUT ONLY TO BE TRAPPED IN SPACE, WARPED BY SOMEONE...SOMEONE AS DEVIOUS AND WARPED AS A SOFTWARE PIRATE. IT'S GOING TO BE A LONG NIGHT DUDE. A REAL PIRATE WOULD ADD HIS OWN MESSAGES INSTEAD OF VANDALIZING THESE DIMENSION-CONTROLLING FORT. This doesn't make much sense, but perhaps the protection is located somewhere on these two blocks.

I've just about given up. I hope this information will prompt someone with a copy of this great game to figure out the softkey for it. Oh, by the way...I was able to easily get into the control panel and use the VISIT MONITOR desk accessory immediately after being asked to insert the key disk. The only problem is, I have absolutely no idea what any of the stuff means when I use the VISIT MONITOR accessory!

Somebody, please help. I would give anything to be able to copy this game.

Softkey for...

## California Games GS

Epyx

The softkey in COMPUTIST #64 (page 37) did not work for me. But this simple, one-byte change made my California Games copyable both onto a hard disk, and bootable from a RAMdisk! Here's the simple change:

Blk	Byte(s)	From	To
\$0D2	\$095	??	80

Now I have a question for all you hackers out there: How in the H\*LL do you figure out which JSR's and JMP's to change when cracking a disk? It seems a little too simple the way you describe it in your softkeys. I'd like to know how you know which ones have to do with the protection, and how you know what to change them to! If someone out there is reading this, please publish a checklist for IIGS software which could give me a list of HEX strings to search for on a typical GS game, what they mean, how to find them, and how to change them. I do know a FEW already, but they don't seem to help. For example, I know that on 5.25" disks 4C 00 C6 means to REBOOT. I'd like to know some standard strings on GS software, and what they mean.

I definitely believe that deprotecting a disk (or at least trying to) is much more fun than playing the actual game! Well, have fun. I'm sure I'll think of a thousand more questions as soon as I put this in the mailbox.

## John Ianzano NY

I am a new Computist subscriber and have the following problem; I'm probably the last person in the United States who's still using a program called Screenwriter 2.2 and I want to save my text files on my 3 1/2 inch disk drive. I've used the softkey for Screenwriter which was published (issue #9 & 10) and now have a

COPYA-able version. The problem is that I still can't save text files to my 3 1/2 inch drive even when I use a modified Dos 3.3 to format my diskette (IE.; Profix, UniDOS). It appears that Screenwriter uses a modified RWTS routine of it's own to save files. A small insight into the problem appeared in issue 36 when it was described how to use Screenwriter with the Flashcard. Reference was made that Screenwriter would work with a normal Dos 3.3 RWTS but no description was elaborated on.

I would appreciate hearing from anyone who could help....Thanks.

## Marc Batchelor FL

I thought I'd better pass along some softkeys I have been working on for a while. Since my teacher friend was unable to make reliable back-up copies with his bit-copiers, I was called in to remove the protections. It is truly sad that the software manufacturers do not make unprotected copies for teachers to use in the classroom. There are only about two dozen ways that a seven year-old can abuse an original disk (excluding creativity with a hole-punch). That ends up to be costly to the school district. Therefore, I developed these softkeys.

Softkey for ...

## Ten Clues High Wire Logic Botanical Gardens A Science Experiment Tip 'N Flip Gnee Or Not Gnee

Sunburst Software

Requirements:

A way to reset into the monitor  
Demuffin Plus

Sunburst Software uses a highly modified RWTS. However, armed with Demuffin Plus, breaking them is a snap.

1. Format as many blank disks as you have originals.
2. Blood Demuffin Plus at \$6000.
3. Boot any one of the DOS 3.3 series listed above and use a NMI card or similar way into the monitor. (I use the Senior Prom).
4. Put Demuffin Plus where it belongs.  
803-6000.8103M
5. Start Demuffin Plus  
803G
6. Select convert files, and follow the prompts.

Softkey for...

## Award Maker Plus

Baudville

For Award Maker Plus, I found the crack to be a two byte change to the code on track \$00 sector \$05 bytes \$FA-FB. Edward Teach's crack was to change these bytes to A9 00. On my version, the code following that change toggles the language card to \$C080,X after the A register was transferred to the X register (TAX). With \$00 transferred from the accumulator to the 'X' register this would result in LDA \$C080,0 or just \$C080. This has the net result of write-protecting the language card. Since the printer driver is loaded into the language card (around \$FF00 I think) the program crashes into the monitor as soon as the printer driver was accessed (because the program attempted to load the driver into write-protected RAM). Knowing this, I used Edward Teach's logic (thanks Edward) and changed his crack to A9 01 (instead of A9 00). This allows the driver to be loaded into the RAM card and function normally. I have printed out many certificates using the copy. It functions as well as the original. Please note that this is for my version so I'm not discrediting Edward Teach's crack. If you are uncertain, try both. Just to be on the safe side, print out several certificates in several configurations to be certain that the program does function properly.

Trk	Sec	Byte(s)	From	To
\$00	\$05	\$FA-FB	05 A5	A9 01

Softkey for...

## Tag Team Wrestling

Data East

Requirements:

COPYA  
Disk Searcher and Sector editor

The first step in cracking this worthless game is to copy it with COPYA modified to ignore DOS errors (B942:18). From there, I boot-code traced the program until I came upon this piece of code:

XXBE	20 00 BF	JSR	\$BF00	Disk check
XXC1	90 03	BCC	XXC6	
XXC3	4C DB BE	JMP	\$BEDB	Crash!
XXC6				Program Start

To circumvent the protection was as simple as changing the JSR to \$BF00 to clear the carry bit (CLC) and 2 no-operations (NOP). This had the

side benefit of a faster booting disk (no disk check) and a deprotected copy!

1. Boot your DOS 3.3 system disk.
2. Tell DOS to ignore checksum and epilog errors and use COPYA to copy the disk.  
POKE 47426,24  
RUN COPYA
3. Run your sector editor with search capabilities and search for 20 00 BF 90 03. Change to 18 EA EA 90 03.
4. Write the sector back to disk.
5. (Optional) - Format original and copy since the program is worthless.

Softkey for...

## Story Tree

Scholastic Software

Requirements:

A way to capture altered RWTS  
SUPER IOB  
SWAP controller

This program looked like it was going to be easy to crack, but it had a single surprise. It uses altered RWTS as their sole protection. The crack is not as simple as capturing the RWTS, using the SWAP controller and using your own DOS however, because it crashes into the monitor at the menu. After examining the originals RWTS, Scholastic decided to be cute by putting a RTS at a known location and CALLing it from all the BASIC programs. At first I thought of removing all of the calls. However, I deemed it easier to POKE an RTS to that location at the beginning of the HELLO program (SETUP) instead of trying to locate all of the CALLs.

1. Capture the program's RWTS using whatever means available.
2. Use SUPER IOB SWAP controller to copy the disk to a normal format.
3. Put your own DOS on the disk.
4. Load the program SETUP and add a line at the beginning.  
LOAD SETUP  
5 POKE 46784,96
5. Save the program back out to the disk.  
SAVE SETUP.

That's all on this one.

Softkey for...

## Body In Focus

Mindscape

Requirements:

A way to capture altered RWTS  
SUPER IOB  
File copier  
Formatted disks

This one is easy. The only protection is a modified RWTS.

1. Capture the programs RWTS using any means available.
2. Use SUPER IOB SWAP controller to copy the disks to a normal format.
3. Use any file copier to copy the files off of the copies onto DOS 3.3 formatted disks.  
Done.

Softkey for...

## VCR Companion

Broderbund Software

Requirements:

COPYA  
Disk editor and searcher

This disk uses a modified ProDOS (shame shame). It also uses a disk and memory verification routine that resides in memory beginning at \$2520. The routines are in the system file VCR.SYSTEM. Copying the disk is not a large task since it only involves making a change to DOS 3.3 to ignore errors and running COPYA. The resulting copy will not run. Using my Senior Prom, I found the routines. My first attempt was NOP all branches to the spoiler routines. This worked well, but the disk was still being checked (although the outcome did not matter). After examining the routines, I found a way to circumvent the bizarre disk routines and just load the software. Here are some excerpts from the routines:

2512:	38	SEC	Error Routine
2513:	60	RTS	
2520:	29 0F	AND	#\$0F Check the accumulator
2522:	C9 04	CMP	#\$04
2524:	D0 EC	BNE	\$2512 Goto error routine if not good.
2526:	AA	TAX	
2527:	BD 00 60	LDA	\$6000,X Check Memory For Tampering
252A:	DD 18 25	CMP	\$2518,X
252D:	D0 E3	BNE	\$2512
252F:	CA	DEX	
2530:	D0 F5	BNE	\$2527
2559:	C6 F5	DEC	\$F5
255B:	F0 5C	BEQ	\$25B9 If \$F5 is zero, crash
255D:	20 DD 25	JSR	\$25DD Disk Check Routine

2560:	B0 57	BCS	\$25B9 Crash if error
2562:	A5 F1	LDA	\$F1 Check for special flag
2564:	C9 07	CMP	#\$07
2566:	D0 F1	BNE	\$2559 If no flag, try disk check again
256A:	BD 8C C0	LDA	C08C,X Another Disk Check
25AB:	BD 8C C0	LDA	\$C08C,X
25AE:	10 FB	BPL	\$25AB
25B0:	D1 D6	CMP	(\$F6),Y
25B2:	D0 05	BNE	\$25B9 Crash if incorrect byte found!
25B4:	88	DEY	
25B5:	10 F4	BPL	\$25AB
25B7:	30 03	BMI	\$25BC If ok, branch around next jump
25B9:	4C CC 25	JMP	\$25CC Jump to crash
25BC:	A0 F0	LDY	#\$F0 Disk OK
25BE:	B9 00 02	LDA	\$0200,Y
25C1:	99 00 00	STA	\$0000,Y
25C4:	C8	INY	
25C5:	D0 F7	BNE	\$25BE
25C7:	BD 88 C0	LDA	\$C088,X
25CA:	18	CLC	
25CB:	60	RTS	
25CC:	C6 F4	DEC	\$F4 Disk is a copy
25CE:	F0 03	BEQ	\$25D3
25D0:	4C 55 25	JMP	\$2555
25D3:	38	SEC	
25D4:	60	RTS	

Seeing the above, it can be figured what my first plan of attack was. I NOPped every branch I could find to \$2512 and \$25B9. I essentially allowed the program to play with the disk as much as it wanted and pass the check anyway. As it turned out, I had 33 sector edits at first, but it ran (so no insults, ok?). Revising my plan of attack, I changed the code at \$2520 (the start of the memory check) to 18 90 0F which clears the carry (CLC) and branches to \$2532. My second edit was starting at \$255B (start of disk verification) changing to A9 07 85 F1 18 90 5A. This translates to loading the accumulator with \$07 and storing it at \$F1 (remember the flag?). I then clear the carry flag (CLC) and branch to the pass routine at the end (\$25BC). This bypasses the disk check AND forces the program to store essential bytes in memory.

1. Boot your DOS 3.3 system disk.
2. Tell DOS to ignore checksum and epilog errors and use COPYA to copy all sides of the VCR Companion disks.  
POKE 47426,24  
RUN COPYA
3. Boot the disk searcher and search for 29 0F C9 04 D0 EC AA. Change the 29 0F C9 to 18 90 0F.
4. Search the same sector for F0 5C 20 DD 25 B0 57. Change to A9 07 85 F1 18 90 5A.
5. Write the sector back to the disk.
6. Copy a new version of ProDOS to this disk.

Softkey for...

## Sign Designer

Channelmark

Requirements:

SUPER IOB SWAP  
Altered RWTS (see below)  
Sector Editor with search capabilities

This Pascal based program gave me fits. In an attempt to figure out the protection, I might have stumbled upon a new form of laziness. Instead of taking the time to create a complex controller, I decided to create my own modified RWTS (if they can, why can't we?) and use the SWAP controller. Talk about lazy. Anyway, aside from altered address and data headers and tailers, there is no other protection. But, once the disk is converted to a normal format, it must be modified to accept normal headers and tailers. Here is how:

1. Move a copy of normal RWTS down to \$1900.  
1900-B800.BFFFM
2. Modify the heck out of it to read the modified disk:  
19E7:AA  
19F1:D5  
19FC:EB  
1A3E:AA  
1A55:AA  
1A5F:D5  
1A6A:AB  
1A91:DE  
1A9B:AB
3. Save it as RWTS.SIGN.  
BSAVE RWTS.SIGN,AS1900,L\$800
4. Run SUPER IOB with SWAP controller installed to copy the disk. Use the "Ignore unreadable sectors" patch to the SWAP controller since sector \$00 of track \$00 is in a normal format, but the rest of the disk is in a messed up format.
5. Boot up your sector editor and copy track \$00 sector \$00 from the original to the copy. Track \$00, sectors \$00, \$0C and \$0D all look for altered marks.

Trk	Sec	Byte(s)	From	To
00	00	\$10	?	D5
		\$19	?	AA
		\$23	?	96
		\$4D	?	D5



OC \$56 ? AA  
 \$60 ? AD  
 \$0B ? D5  
 \$15 ? AA  
 \$20 ? 96  
 \$47 ? DE  
 \$51 ? AA  
 OD \$9D ? D5  
 \$A7 ? AA  
 \$B2 ? AD  
 \$EB ? DE  
 \$F5 ? AA

That's all of the softkeys I have at the present, but be expecting more in the near future.

**Jeffrey A. Wisnia MA**

I sure hope you guys make it. Here's my contribution in return for the countless hours of pleasure you've given me since I became a subscriber in 1982.

I'm enclosing a hardware article which may be of interest to readers with Apple IIe machines.

**The Junior Prom**

Back when I had an Apple II+, I followed Ernie Young's instructions in COMPUTIST #6 and replaced the F8-ROM in my machine with a 2716 EPROM containing his "reset to the monitor" and page 0-8 moving routines. When I graduated to an Apple IIe (enhanced) I suffered without those helpful features until I modified my antique EPROM burner to program 2764 chips.

This article will show you how to replace the CD-ROM in an enhanced Apple IIe with an EPROM I call the JUNIOR PROM. With it you can reset to the monitor at will or reset to the monitor with memory from \$0000-\$0900 copied to \$2000-\$2900 and the stack pointer copied to \$2901. Memory from \$2000-\$3FFF is the Hires screen area, which usually isn't part of the permanent program code in Hires games, so you can usually capture all the code from single load programs in one shot.

The memory copy feature lets you examine the program code located at \$400-\$7FF, which otherwise gets overwritten by text on the screen as soon as you enter the monitor, as well as page zero, the stack, and the page two keyboard buffer, areas which get altered by a reset to the monitor or by entering commands from the keyboard. The ability to copy these pages where they don't get altered is very helpful for general software snooping and copy protection analysis. The memory copy routine itself is lifted directly from the original Ernie Young's original article.

In addition, the IIe's nasty habit of blasting two bytes in every page of RAM on a reboot is exorcised in the altered ROM.

You will need a 2764 EPROM and access to an EPROM programmer which can burn the contents of a 8K long binary file into the 2764. These EPROMs are presently available for under \$5 each from most electronic parts suppliers catering to individuals, check the ads in any hobby electronic magazine.

The Junior Prom will leave your Apple IIe without cassette tape storage routines, but you won't miss these dinosaurs. Applesoft BASIC under ProDOS does not even support tape storage and issues a SYNTAX ERROR in response to SAVE and LOAD commands. To keep things neat, my coder returns an ERR message for monitor tape commands W and R, and Applesoft Basic's SAVE and LOAD under DOS 3.3.

Note that the JUNIOR PROM won't work in an unenhanced IIe, but by now you should have upgraded to the enhanced version anyway, to get the faster 80 column routines and Mousertext.

First, you must capture the code of the CD-ROM in your IIe by moving it down in RAM. You can't BSAVE it directly to disk because it occupies the same memory area as the disk controller, which gets switched off when the CX-ROM is switched in. My EPROM programmer wants its data loaded at \$2000, so that's where I chose to move it.

To read the CX-ROM from the monitor you have to tinkle \$C007 with a write command in order to switch it into the \$C100-\$CFFF space normally occupied by peripheral card ROM. The CD-ROM in your IIe contains zeros from \$C000-\$C0FF, but this range of the ROM is never switched in, as that memory range is reserved for the Apple's I/O softswitches, annunciators, game paddles and such.

Enter the monitor:  
**CALL -151**  
**C007:00** *switch in CX-ROM*  
**2100<C100.DFFFM** *copy memory*  
**2000:00 N 2001<2000.20FEM** *zeros C000-C0FF*  
**C006:00** *switch the slot ROMs back in*  
**BSAVE CD.ROM, A\$2000, L\$2000** *if you mess up later, you can reload this*

You now have an image of the CD-ROM in memory. Enter the following hexdumps from the monitor, changing the high byte of the addresses if you saved the CD-ROM code at a starting location other than \$2000:

**PART1**

22C0: 4C D0 C2 AD 61 C0 10 1A \$8496  
 22C8: A9 00 8D F4 03 4C E2 C2 \$3A7C  
 22D0: 2C 00 C0 10 FB AD 10 C0 \$9045  
 22D8: AD 00 C0 4C AD C5 EA EA \$F2D8  
 22E0: EA EA \$4123

**PART2**

2598: 20 2D FF 20 62 EC 68 68 \$0DE8  
 25A0: A9 FE 48 A9 C4 48 60 00 \$CAB6  
 25A8: 00 00 4C 98 C5 C9 15 F0 \$03E8  
 25B0: 07 C9 4D F0 3E 4C 00 C6 \$A09B  
 25B8: BA 8E 01 29 A0 00 B9 00 \$CCBC  
 25C0: 00 99 00 20 B9 00 01 99 \$022A  
 25C8: 00 21 C8 D0 F1 4C D4 C5 \$20F5  
 25D0: EA 4C 98 C5 84 3C 84 42 \$4AAA  
 25D8: 84 3E A9 09 85 3F A9 02 \$3818  
 25E0: 85 3D A9 22 85 43 20 2C \$AC69  
 25E8: FE A9 OD 8D D0 07 A9 3E \$021B  
 25F0: 8D D1 07 A9 FF 48 A9 58 \$BCC03  
 25F8: 48 4C C5 FE FF D4 00 00 \$4DE8

Save the JUNIOR PROM code:  
**BSAVE JR.PROM, A\$2000, L\$2000**  
 As a check that you didn't accidentally change anything elsewhere in the code, compare it with the original:  
**BLOAD CD.ROM, A\$4000**  
**2000<4000.5FFFV** *monitor verify command*

You should see differences in the changed areas \$22C0-\$22E1 and \$2598-\$25FF only. Any other differences mean you messed up somewhere and should start over.

Program a 2764 with the code you saved as JR.PROM. Turn off your Apple, pull the CD-ROM and install the JR.PROM. Check the orientation of the EPROM making sure the notched or dotted end points toward the keyboard, the same as the adjacent chips. A reversed chip will be destroyed the instant you turn on your Apple, and might take out something else in the process too!

Using the JR.PROM will make no difference in the normal operation of your computer, except for the loss of cassette tape functions. The two byte ROM checksum was made the same as the original CD-ROM, so it will pass ROM checksum tests made by some copy protected software.

To use the added features of the JR.PROM, press the control, closed Apple and reset keys. (Press reset after the other two keys are down). Your Apple IIe should freeze, awaiting the next keypress. What happens next depends on which key you hit:

Press M (upper case M) to drop into the monitor.

Press -> (right arrow) to drop into the monitor with the memory copy and stack pointer saves described above. An inverse "M>" will print in the lower left corner of the screen to indicate that memory copy was done.

Pressing any other key will start the Apple's diagnostic routines.

**Disassemblies of the new code:**  
 The start of the original reset routine is \$C2B0.

C2B0 A9 FF LDA #\$FF  
 C2B2 8D FB 04 STA \$04FB *blast mode byte*  
 C2B5 AD 5D C0 LDA \$C05D *reset annunciators*  
 C2B8 AD 5F C0 LDA \$C05F  
 C2BB AD 62 C0 LDA \$C062 *test closed apple key*  
 C2BE 10 03 BPL \$C2C3 *not pressed, try open apple*

The above code is unchanged in Junior Prom, and is shown for reference.

C2C0 4C D0 C2 JMP \$C2D0 *pressed, get next key*  
 C2C3 AD 61 C0 LDA \$C061 *test open apple key*  
 C2C6 10 1A BPL \$C2E2 *not pressed, goto reset*  
 C2C8 A9 00 LDA #00 *pressed*  
 C2CA 8D F4 03 STA \$03F4 *destroy powerup byte*  
 C2CD 4C E2 C2 JMP \$C2E2 *jump to reset (will boot)*  
 C2D0 2C 00 C0 BIT \$C000 *test keyboard*  
 C2D3 10 FB BPL \$C2D0 *wait for keypress*  
 C2D5 AD 10 C0 LDA \$C010 *clear keystrobe*  
 C2D8 AD 00 C0 LDA \$C000 *get key value*  
 C2DB 4C AD C5 JMP \$C5AD *goto rest of new routine*  
 C2DE EA NOP  
 C2DF EA NOP  
 C2E0 EA NOP  
 C2E1 EA NOP

New return from tape read or write calls is at \$C598.

C598 20 2D FF JSR \$FF2D *monitor print "err"*  
 C59B 20 62 FC JSR \$FC62 *monitor print C/R*  
 C59E 68 PLA *pull return address*  
 C595 68 PLA  
 C5A0 A9 FE LDA #\$FE *push return address*  
 C5A2 48 PHA  
 C5A3 A9 C4 LDA #\$C4  
 C5A5 48 PHA  
 C5A6 60 RTS *jump to \$FEC5 via RTS*  
 C5A7 00 BRK *Note: \$FCE5 turns off*  
 C5A8 00 BRK *CX-ROM and then does*  
 C5A9 00 BRK *another RTS*

Old tape write entry point is \$C5AA. It is called from EF-ROM, so we must use it too.

C5AA 4C 98 C5 JMP \$C598 *goto new return routine*

Keypress tests begin here at \$C5AD.

C5AD C9 15 CMP #\$15 *right arrow key?*  
 C5AF F0 07 BEQ \$C5B8 *Yes, goto memory copy*  
 C5B1 C9 4D CMP #\$4D *"M" key?*  
 C5B3 F0 3E BEQ \$C5F3 *Yes, goto exit code*  
 C5B5 4C 00 C6 JMP \$C600 *Neither, jump to*  
 C5B8 BA TSX *diagnostics*  
 C5B9 8E 01 29 STX \$2901 *start of Young's routines*  
 C5BB A0 00 LDY #00 *Save stack pointer*

C5BE B9 00 00 LDA \$0000,Y *copy first two pages*  
 C5C1 99 00 20 STA \$2000,Y *this way to avoid*  
 C5C4 B9 00 01 LDA \$0100,Y *changing any*  
 C5C7 99 00 21 STA \$2100,Y *memory in them*  
 C5CA C8 INY  
 C5CB D0 F1 BNE \$25BE *loop till copy completed*  
 C5CD 4C D4 C5 JMP \$C5D4 *jump over old tape read*  
 at \$25D1

C5D0 EA NOP  
 Another old tape read entry point is \$C5D1. It is called from EF-ROM, so we must use it too.

C5D1 4C 98 C5 JMP \$C598 *goto new return routine*  
 Continue with new code at \$C5D4.

C5D4 84 3C STY \$3C *Setup for monitor move*  
 C5D6 84 42 STY \$42 *routine, (Y=0 at entry)*  
 C5D8 84 3E STY \$3E  
 C5DA A9 09 LDA \$09  
 C5DC 85 35 STA #3F  
 C5DE A9 02 LDA #02  
 C5E0 85 3D STA \$3D  
 C5E2 A9 22 LDA \$22  
 C5E4 85 43 STA \$43  
 C5E6 20 2C FE JSR \$FE2C *monitor memory move*  
 C5E9 A9 0D LDA #0D *screen inverse "M"*  
 C5EB 8D D0 07 STA \$07D0 *store lower left screen*  
 C5EE A9 3E LDA #3E *screen inverse ">"*  
 C5F0 8D D1 07 STA \$07D1 *store next to "M"*  
 C5F3 A9 FF LDA #FF *push monitor entry return*  
 C5F5 48 PHA *address onto stack*  
 C5F6 A9 58 LDA #58  
 C5F8 48 PHA  
 C5F9 4C C5 FE JMP \$FEC5 *jump to \$FEC5*  
 C5FC FF ??? *these two bytes make the*  
 C5FD FF ??? *ROM checksum come*  
 C5FE 00 BRK *out right*  
 C5FF 00 BRK

Note: The Applesoft SAVE and LOAD commands produce double "ERR" messages when running under DOS 3.3 or with DOS disconnected. This is because these Applesoft commands each make two calls to the monitor tape WRITE and READ routines before they are done. Eliminating this minor glitch looked like it would take a lot more code or a change to the EF-ROM and didn't seem worth it.

**Bob Igo PA**

**Enhancements to APT Scanner**

Just add or modify the following lines in the BASIC program and type in the new binary file "SCANNER.AI" below and save it and you will have what I call an "artificial intelligence" option. The program chooses the most likely locations for the necessary APT information by checking after each occurrence of LDX #\$\$x, LDY #\$\$x or LDA #\$\$x to see if there is a store command. If not, it doesn't tell you. In case it eliminates a necessary location, I have the option of using no screening.

**APT Scanner Patches**

**LOAD APT.SCANNER**  
 95 IF PEEK (768) > 169 THEN PRINT CHR\$(4) "BLOADDOS-UTILITY"  
 100 HOME : PRINT "WOULD-YOU-LIKE-ME  
 ~TO-USE- MY-INTELLIGENCEAND-FOCUS  
 ~ONLY-ON-THEMOST-LIKELY-CHANCES?"  
 105 GET GS: PRINT GS: IF NOT (GS = "Y" OR GS = "N") THEN CALL -198: GOTO 100  
 106 IF GS = "Y" THEN PRINT CHR\$(4) "BLOAD~SCANNER.AI" : GOTO 110  
 107 PRINT CHR\$(4) "BLOAD~SCANNER"  
**SAVE APT SCANNER**  
 Enter the new scanner assembly program and save it.

**SCANNER.AI**

6000: A9 A9 8D 00 61 A9 A2 8D \$8439  
 6008: 01 61 A9 A0 8D 02 61 A0 \$6F86  
 6010: 00 A2 00 B9 00 20 DD 00 \$A68E  
 6018: 61 F0 09 E8 E0 03 D0 F3 \$7E10  
 6020: C8 D0 EE 60 B9 01 20 CD \$E1A7  
 6028: 50 61 D0 EF 8E 03 61 A2 \$4D89  
 6030: 0D BD 69 60 D9 02 20 F0 \$E0A1  
 6038: 09 CA D0 F5 AE 03 61 4C \$A5C7  
 6040: 1B 60 A9 00 85 24 AE 03 \$E4CB  
 6048: 61 AD 10 03 20 DA FD A9 \$6F83  
 6050: 10 85 24 AD 15 03 20 DA \$C02E  
 6058: FD A9 20 85 24 98 20 DA \$5ECA  
 6060: FD 20 8E FD AE 03 61 4C \$B653  
 6068: 1B 60 85 95 8D 9D 99 91 \$66C9  
 6070: 81 86 96 8E 84 94 8C \$58C7

**BSAVE SCANNER.AI, A\$6000, L\$77**

**Scanner.AI Disassembly**  
 A9 A9 LDA #A9  
 8D 00 61 STA \$6100  
 A9 A2 LDA #A2  
 8D 01 61 STA \$6101  
 A9 A0 LDA #A0  
 8D 02 61 STA \$6102  
 A0 00 LDY #00  
 A2 00 LDX #00  
 B9 00 20 LDA \$2000,Y  
 DD 00 61 CMP \$6100,X  
 F0 09 BEQ \$6024  
 E8 INX  
 E0 03 CPX #03  
 D0 F3 BNE \$6013  
 C8 INY  
 D0 EE BNE \$6011  
 60 RTS  
 B9 01 20 LDA \$2001,Y

CD 50 61 CMP \$6150  
 D0 EF BNE \$601B  
 8E 03 61 STX \$6103 *New stuff*  
 A2 0D LDX #0D  
 BD 69 60 LDA \$6069,X  
 D9 02 20 CMP \$2002,Y  
 F0 09 BEQ \$6042  
 CA DEX  
 D0 F5 BNE \$6031  
 AE 03 61 LDX \$6103  
 4C 1B 60 JMP \$601B  
 A0 00 LDA #00  
 85 24 STA \$24  
 AE 03 61 LDX \$6103 *New*  
 AD 10 03 LDA \$0310  
 20 DA FD JSR \$FDDA  
 A9 10 LDA #10  
 85 24 STA \$24  
 AD 15 03 LDA \$0315  
 20 DA FD JSR \$FDDA  
 A9 20 LDA #20  
 85 24 STA \$24  
 98 TYA  
 20 DA FD JSR \$FDDA  
 20 8E FD JSR \$FD8E  
 AE 03 61 LDX \$6103 *New*  
 4C 1B 60 JMP \$601B  
 85 95 8D 9D 99 91 81 86 96 8E 84 94 8C *Opcodes for store commands*

Using this program, I've come up with some more APT's.

**Advanced Playing Technique for... Trolls and Tribulations:**

2  
 Unlimited Lives  
 Trk Sct Byte(s) From To  
 08 08 CB-CC C6 13 EA EA

**Advanced Playing Technique for... Microwave**

2  
 Unlimited Lives  
 Trk Sct Byte(s) From To  
 11 0D 3E-40 CE BD 08 EA EA EA  
 19 0A 42-44 CE BD 08 EA EA EA

**Advanced Playing Technique for... Oil's Well**

*Sierra On Line*  
 Extended Lives  
 Trk Sct Byte(s) From To  
 17 07 5C 03 FF (0-FF)

**How to use APT SCANNER**

As Mr. Polasky requested, here is an explanation of my technique with regards to Oil's Well. First, let me say that I tried the timer but was unsuccessful. I know that the number 99 (\$63) is stored at location \$6927 on track \$17, sector \$0C (it was not necessary to search for something like 990 because the time goes down in factors of ten), but it isn't being decremented at all. The program is apparently using some sort of unorthodox way of taking the value in \$6927 and storing it somewhere else, messing with it and decreasing it. I've scanned memory for the time at various points but to no avail. Help!! Someone else out there must be able to defeat this.

Now, for the lives feature. I was unable to make unlimited lives because of the same odd schemes I described above, but I managed to extend them. I read that Frank desired a little APT help. I needed an example to use with my updated APT techniques. In numbered steps, here is what I did:

1. I booted up the game and saw that three lives were displayed on the screen. This meant that I would need to scan for 03 with the APT SCANNER.
2. I booted up APT SCANNER and chose the new "Artificial Intelligence" option. I chose 0 as the starting track and 34 as the ending track. I used slot 1 for my printer, but slot 0 is OK for the monitor. After the SCANNER was done, it had told me the following information:

TRACK	SECTOR	BYTE
00	0D	A6
01	03	90
01	05	8C
10	0B	96
15	00	01
15	02	DC
16	02	3D
17	06	DF
17	06	EF
17	07	5B
17	09	61
17	0F	1D

This means that in all these places, 03 is being stored in a certain memory location. Although a fully independent version of APT SCANNER is on the horizon, we must for now use a sector-editor with disassembly capabilities, such as Copy II+, for the next step.

3. Boot up Copy II+ and get into the sector-editor. Read each one of the above locations (although tracks 0-2 can usually be ignored, as this is where the DOS resides most of the time).



For example, the first one I read was track \$10, sector \$0B. I jumped to byte \$96 and used the (L)ist option. It told me that 03 was being stored somewhere in DOS, so I figured that it couldn't be the number of lives (it turned out later that I figured correctly). So, I read the rest of the locations and found the following storing addresses:

Trk	Sct	Byte	Storing location (in Hex)
15	00	01	0363, 0364
15	02	DC	0376
16	02	3D	8429
17	06	DF	0353
17	06	EF	0363, 0364
17	07	5B	0225, 0226, 0385, 902A
17	09	61	0229,X
17	0F	1D	6B00,X

4. Now, boot up the game and get "killed" once. You should currently have two lives. Break the program's execution. If you can't do this without making the program reboot itself, use CTRL-OPEN APPLE-RESET and then immediately after the computer reboots, hit CTRL-RESET. It may mess up a bit of memory, so you might want to try searching the disk for F2 03 and see what the program is doing to the reset vector (\$3F2-\$3F4). Look one byte before F2 and list. If it is storing anything at 3F2, 3F3, or 3F4, just NOP the entire area. This should enable a safe CTRL-RESET. Anyway, the idea here is to look at all the memory locations above (storing locations) and see if any of them have 02, our current number of lives, in them. The reason I think it's best to get "killed" once before looking at the locations is because it is more likely that 03 is going to be in a location that isn't the number of lives because we know that 03 is being stored in every location above at least once. The chance of finding an 02 after we lose one life is less probable and therefore more accurate. If you have a multiple player option, choose it and lose one life per player. This also helps to make things more accurate. I looked at all the above locations after getting killed once. I found 02 to be in location \$225. Because this is a two-player game, I checked again for 02 and found it in location \$226. I already told you about the trouble I had with making an unlimited lives feature, so I'll just tell you what I did in this case. If you want to know how to make "unlimited" options in other cases, read Computist #65, page 17, under steps 5 and 6.

5. I tried changing byte \$5C on track \$17, sector \$07 from \$03 (for three lives) to \$FF (which should make most people happy). I booted the game, and aside from a large amount of little munchie-looking things which display the current number of lives, the game functions fine.

So, that's how I did it. No magic or anything. If someone does know how to make this option unlimited, please let me know how you did it.

#### Bugs

There were a couple of small errors in my DeathSword APT article that were pointed out to me. They might be a bit confusing for some, so I'll tell you what they should be. I said under section 2 that DEATH.SWORD began on track \$05, sector \$09 and ended on track \$09, sector \$06. That is correct. However, under section 3, I said that "I read track \$09, sector \$06 which is where the file DEATH.SWORD starts..." This should have read "track \$05, sector \$09" instead. Also, under section 5 (now, this was a half typo, half temporary brain damage error) I stated that the number, \$1234 was a 4-byte number. Actually, it's a 2-byte number. \$12345678 would be a 4-byte number, and \$4B is a 1-byte number. Sorry about any confusion I may have caused.

#### Mopman

#### MA

I received the urgent message and I am sorry to hear that Computist is going to reduce the number of issues. Before you receive this you should already have my check for my membership. In spite of a high price, I feel that I have gotten more than my money's worth from the magazine. I have not been a big one on keeping notes so a lot of cracks that were simple or very similar to published ones have been lost forever. But here are some that were unusual enough for me to keep good notes on. In the future I will try to be more active in submitting softkeys for all cracks. Two of them involve the use of Copy 2+'s more advanced parameters. On the subject of parameters Copy 2+ has a lot of undocumented parameters that they say are used "to control very specific copy methods for certain protection schemes". Does anybody have any information on these? I really prefer to make my programs COPY-able. But I guess the main objective is to make a backup by whatever means available.

Softkey for...

#### Dinosaur Days

##### Pelican Software

This softkey requires that you be reasonably familiar with the use of the nibble editing feature of COPY 2+. When completed you will have a utility disk that will copy and deprotect Dino Days and some other Pelican software. When viewed with a nibble editor DINO DOS looks like this when compared to a normal DOS 3.3 address header.

#### Normal

```
D5 AA 96 FF FE AA
AA AA AA FF FE DE AA EB
```

#### Dino DOS

```
D5 FF FE D5 FF FE xx xx D5 FF FE AA AA
AA AA FF FE FF FF
```

D5 FF FE repeated twice, one or two odd bytes then D5 FF FE, followed by the track, sector, checksum and epilog. The epilogs have been changed to FF FF.

Capturing the RWTS and using a swap controller would not produce a working copy. I suppose I could have BOOT TRACED but I never really had much luck at it. I am pretty good with a nibble editor, so I produced my first copy by changing the address header on all the sectors before the track was written to disk. After doing all this I found that DINO DOS has the ability to read their protected format, or read and write normal DOS 3.3. So you only have to be concerned with capturing the first three tracks. Track 0 has only the address epilogs changed so most of the work has to be done on track 1 and 2.

Boot Copy 2+ and format a blank disk (DOS 3.3). Get to the Bit Copy and Sector Copy menu. Select Sector Edit and press "P", patched. Then choose DOS 3.3 PATCHED. Escape out of this mode and select Sector Copy. Copy only Track 0 from your original to your formatted disk. Then select Manual Bit Copy. When asked, Start Track 1, End Track 2, Sync No, Keep Length No. Press / to modify parameters, what parm. 0B to what value 02. Changing 0B to 02 puts you in the nibble editor before copying to your destination disk. So press return to begin copy. When the editor displays the track buffer you probably will not be near sector 0. Hold down the "T" key to scan back to the beginning of the buffer. When it beeps you are at the beginning. Press "Control B" to set this as the beginning. Press "F", Find, then type AA AA and press return. You should see: D5 FF FE D5 FF FE xx xx D5 FF FE AA AB AA AA FF FF FF FF. You should be on the first AA of the AA AA bytes. Use the "J" key to move 7 places to the left. Type "C" to change the bytes to D5 AA 96 then press return. Then use "J" to move you back to the D5 you just entered, and press "Control B" to reset the track beginning. Type "F", Find, and type D5 FF FE and press return. Press "R", Repeat Find, twice and you should be positioned on D5. Press "J" twice and press "C", and type D5 AA 96 again. Repeat this for the remaining sectors. When you do the 16th, sector do a "R" one last time. Then look back about 4 lines and find DE AA EB. Using the I, J, K, M keys, position the cursor on the byte after EB. Press "Control E" to set the track end. In the upper right corner of the screen you should see LENGTH, and it should read approximately 17DF bytes. Scan through the sectors and check to make sure you did not miss any. When complete press "Q" to quit and write to the destination disk. Repeat procedure for track 2.

Again use the sector editor and select DOS 3.3 PATCHED. Read the sectors on track 1 and 2 to make sure they are all readable. If some are not readable repeat the procedure until they are. Selecting DOS 3.3 Patched on the sector edit menu also sets this parameter for Sector Copy. Use your newly created disk as the source disk and use Sector Copy to recopy it. This fixes the bad address checksums. Boot your System Master disk and enter the monitor, CALL-151. Tell DOS to ignore address epilogs B993:00 B99D:00. Reenter basic, 3DOG, and run Copy A. This gives you a disk with DOS that can handle their protection or normal disks. On this disk you can add a copy program such as Super IOB with a standard controller, Copy A, FID, or most any that does not have its own DOS. The current booting program of DINO DOS is called HI, so you need to change it, or change the name of the copy program you are using. The utility disk you have made will also copy Limited Edition Mini Converter by Pelican.

Bitkey for...

#### Story Tree

##### Scholastic

#### Magic Spells

##### Learning Co.

This details how to make a bit copy of these Scholastic titles and also quite a few other programs using similar protection.

In general track 0 is normal. Most of the disk will have altered Epilogs and usually 2 or 3 tracks will have only 1 or 2 areas of valid data. Each of these areas will contain 5 sectors, 3 4 5 6 7, A B C D E, 1 2 8 9 F they may be written on full tracks, 2, 3 or half tracks 2, 2.5, 3 or any other combination of quarter, half or full tracks. Because the tracks can overlap it is very important to set the copy program not to erase the track before writing to it. They normally write \$782 bytes per group of data. Between the groups of data is invalid bytes not sync bytes. For this reason it is very important that you start with a new disk or erase a disk with a magnet for use as a destination disk.

Its best if you write a Copy 2+ parameter to do the copying, because to do a different program, all you may have to do is alter the track numbers. This are the parameters for Story Tree.

T0-T2, 55=03

T3, 0D=01, 44=01, 4D=00, 55=03, 45=07, 46=82, 15=AA, 16=AB, 29=AA, 2A=AB, 2D=FF, 2E=FF

T3.5, 0D=01, 44=01, 4D=00, 55=03, 45=07, 46=82, 15=AB, 16=AE, 29=AB, 2A=AE, 2D=FF, 2E=FF

T4, 0D=01, 44=01, 4D=00, 55=03, 45=07, 46=82, 15=AF, 16=AB, 29=AF, 2A=AB, 2D=FF, 2E=FF

T5-T11, 4D=01, 44=00, 0D=00, 55=03, 15=AA, 16=AA

The parameter for Magic Spells is the same except that in the last line change T5-T11 to T5-T22.

For tracks 0 to 2, the parameter finds the track start by header. For track 3, they set the sector to AA AB, this is sector 1, find track start by header, sync, to sector 1 on track 0, do not erase the track, and cut the track to \$782 bytes.

Track 3.5 is the same except we set the sector to AB AE sector 6

Track 4 we set the sector to AF AB sector B.

Track 5-11 everything is restored to normal.

Softkey for...

#### Case of the Great Train Robbery Mystery of the Witches Shoes Case of the Missing Chick

##### Troll Associates

All 3 of these programs use the same protection. A nibble count on track 3 and a signature check on track 23. But we can easily make these COPY-able. Use a copy program that will ignore the read error on track 3. Such as Copy Disk from the Copy 2+ menu. Copy your favorite DOS to the disk and change the Boot program to "MENU". On Case of the Missing Chick, change the Boot program to "U". That's all.

On other programs, use View Files to find the file that BRUN's a lot of other programs and change it to be the Boot program.

Softkey for...

#### Science 4

#### Understanding our Solar System

##### The Ellen Nelson Learning Library

This is another one of those sneaky signature checks. But it is easy to fix. Boot your System Master disk. Enter the monitor, CALL-151, tell DOS to ignore Address Epilogs B993:0 B99D:0 and ignore Data Epilogs B925:18 60 and return to BASIC, 3DOG. Run COPY A and when done use your sector editor to edit track 0 sector 5. Change byte position \$44 from \$A9 to \$60.

#### Paul A. Johnson

#### IA

To George Cawthorne: Here are two ways to change from a "Block, Address, Change-to" format to a "Track, Sector, Address, Change-to" format. The first method is to edit Super IOB 1.5 to automatically perform the conversion while making sector edits (lines 310-340), and the second method is a program that asks for the block and address and gives the corresponding track, sector and address.

When using the second method, you have to run the program and jot down the conversions next to the block edits in the issue of Computist. Then, when it says to make block edits, make sector edits instead, using your favorite sector editor (I use Copy 2 Plus).

The first method needs a little more explanation. The program "SIOB.BLOCK.FIX" contains only one line. Add this to Super IOB by (1) loading SUPER IOB, and (2) typing the line, and (3) saving Super IOB. Once SUPER IOB is modified, when you want to make block edits instead of sector edits, use the following syntax in the data statements:

```
DATA 3 BCHANGES, Block #, 0, Address #, Change-to
```

The space after the 3 is necessary, and there cannot be a space between the B and CHANGES. The second data item of each block edit is not used, so it can be any number. The variable that contains that number after the read will have the sector number after line 335 is executed.

I have included a sample controller, which uses the information about Moonglum, which was in issue #69. If you have a disk that does not need to be copied with Super IOB, (it is copyable with a fast-copier), then the controller should have the following:

```
TK = First track, sector to be edited
LT = Last track, sector to be edited (minus 1
MOD 16)
FAST=1
```

Or, if you'd rather, copy the entire disk by using TK=0:LT=35:ST=15:LS=15. Re-reading the Super IOB documentation concerning R/W a range and Sector Edits might be helpful.

Now, for some suggestions, questions, and stuff.

Suggestion #1: I noticed that issue #66 of Computist is not available as a back issue. I assume that it is difficult to make photocopies of the tabloid format. If an annual book isn't in the future for these tabloid issues, is it possible to put the issue on disk as text files that the reader can load into their favorite word processor and print out a copy? I don't know how much disk

space this would take, but, even if it took more than one disk, that would be better than nothing for the people who want that information. This suggestion means nothing (of course) if an annual "review" is going to be printed. Then the person could just buy the book.

Suggestion #2: (to the people who write to the RDEX) Is it possible to say a couple of words about the software you are deprotecting. I am not asking for an "all-out" review (we don't want to take Jeff Hurlburt's job), just a couple of simple sentences like "A Role-Playing Game set in future times. Good Game, worth the money." Quite a few times I've read a softkey in Computist and I can't tell if the software is a game, educational program, or a utility of some type. Even if I can figure out a category for the software, I don't know if it is worth 2 cents or not.

Ⓢ This has nothing to do with computers (at least not directly), but every time I have a question, someone who reads Computist has the answer. I recently determined that my house does not have grounded wiring. The outlets are 3-pronged, but only two wires go to the outlet; the ground wire is missing. I need to somehow ground the outlet that my computer uses, but the wiring goes up to the attic (which is not accessible), and then down to the fuse box. We have a finished basement, so I cannot just run a grounded wire directly. Now for my question. Could I use a GFI (ground fault interrupt) outlet, like the ones in the bathroom. The diagram on the package says it is possible, but I thought I'd better ask someone who knows more about electricity than I do. Another thought that I had was to run a wire from the ground post on the outlet to something that is grounded, like the plumbing pipes. Is this a good idea, or am I just asking for trouble? Any help I can get is greatly appreciated, and the sooner I can ground my computer, the sooner I can get a good night's sleep.

#### Free software from Beagle Bros

Stuff #1: Just in case anybody is interested. Beagle Brothers is giving away free software. All you have to do is call up Pro-Beagle, the Beagle Brothers BB. You can download many of the Beagle Brothers older programs, like Beagle BASIC, DOS Boss, Fat Cat, Pro-Byter, and more! The programs on the BB are free, you can even distribute them to your friends. The number for Pro-Beagle is (619) 558-6151. To most people, this is a long distance call, but if you have a fast modem, you can download all of the programs for about the cost of one or two of them at a discount software store.

#### SIOB Block Patch

```
335 IF RIGHTS (A$,8) = "BCHANGES" THEN
  A5 = INT (A1 / 8):A6 = (A1 - A5 *
  8) * 4:A2 = A6 - 15 * (A6 > =
  15):A2 = A2 + 2 * (A3 > 256):A3 -
  A3 - 256 * (A3 > 256):A1 = A5
```

#### SAMPLE.BLK.CON

```
510 REM THIS DELETES LINE 510 IN SUPER
IOB
1000 REM SAMPLE CONTROLLER USING BLOCK
EDIT
1010 TK = 25:LT = 26:ST = 15:LS =
  15:CD = WR:FAST = 1
1020 GOSUB 490:GOSUB 610
1030 T1 = TK:TRK = PEEK (TRK) - 1:
  GOSUB 310:TK = T1
1040 GOSUB 490:GOSUB 610: IF PEEK
  (TRK) = LT THEN 1060
1050 TK = PEEK (TRK):ST = PEEK (SCT):
  GOTO 1020
5000 DATA 3-BCHANGES
5010 DATA 205,0,442,36
5020 DATA 205,0,447,36
5030 DATA 205,0,452,128
5040 REM BLK 205 -> TRK 25, SCT 5 & 7
5050 REM ADD 442 -> SCT 7, ADDR 186
5060 REM 447 -> SCT 7, ADDR 191
5070 REM 452 -> SCT 7, ADDR 196
5080 REM LINE 510 DELETES LINE 510 IN
SUPER IOB. THIS ALLOWS COPYING FROM
DRIVE 1 TO DRIVE 1 WITHOUT A
MESSAGE ASKING TO CHANGE DISKS. IF
YOU ONLY HAVE ONE DRIVE, THEN YOU
NEED TO RELOAD SUPER IOB IN ORDER
TO COPY ANOTHER DISK.
```

#### Checksums

510-\$684E	1050-\$1BE9	5050-\$4E7C
1000-\$232A	5000-\$9858	5060-\$71AE
1010-\$683D	5010-\$B726	5070-\$3BD8
1020-\$6DB6	5020-\$EBE7	5080-\$9D71
1030-\$1685	5030-\$3900	
1040-\$4C82	5040-\$952F	

#### BLOCK.2.SECTORS

```
10 HOME :HX$ = "0123456789ABCDEF"
20 GOSUB 1000
30 TRK = INT (BLK / 8)
40 SEC = (BLK - TRK * 8) * 4 - 15 *
  ((BLK - TRK * 8) * 4 > = 15)
45 IF BY > = 256 THEN BY = BY -
  256:SEC = SEC + 2
50 H = TRK:GOSUB 3000:TRK$ = H$
60 H = BY:GOSUB 3000:BY$ = H$
80 SK$ = MID$(HX$,SEC + 1,1)
100 PRINT : PRINT "Block-$" BLK$
  ",-Byte-$" BY$ "--Track-$" TRK$
  ",-Sector-$" SK$ "-Byte-$" BY$
110 PRINT : PRINT
  "Any-Key-to-Continue" : WAIT -
  16384,128:POKE - 16368,0:GOTO 10
1000 INPUT "Block-#-(in-Hex)-$":BLK$
1005 IF LEN (BLK$) = 0 THEN END
1010 A$ = BLK$:GOSUB 2000:BLK = A
```





My method of deprotection was now clear: Edit the nibble count so it would return \$FE always and edit the branch to disk death using NOP bytes. Here then is the cookbook recipe to completely deprotect Crosscountry Canada.

1. Copy both sides of the original with any fastcopier that ignores errors on T\$02, S\$07.
2. Sector edit T\$00, S\$04, byte \$92 from \$4C to \$00 (This prevents the decoded file from being executed after decoding).
3. Boot the now altered side one copy, and wait for the monitor asterisk prompt. Then edit the hello file in memory.

**0899:EA EA** was D0 ED, removes branch  
**0B37:EA** was C8, removes the INY  
**UNLOCK COPYRIGHT 1986**  
**BSAVE COPYRIGHT 1986, A\$0805, L\$373**  
 Save the modified and decoded hello file  
**LOCK COPYRIGHT 1986**

### DOS 3.2 Controller

Bill Jetzer (in his article "Reading from Protected Disks", COMPUTIST #60 p.11) included a controller to convert DOS 3.2 disks to DOS 3.3. I tried to use this controller with Super IOB v1.5 to access the files on an old 3.2 disk (Game Show) and it would not work. I examined the operations ordered by the controller and found that two GOSUBs referenced the wrong entry points in SIOB1.5. GOSUB 430 in lines 1012, 1014, 1020 and 1030 will not exchange RWTS routines as suggested and should be changed in all cases to GOSUB 360. GOSUB 460 in lines 1020 and 1030 simply prints a message, waits for a keypress and returns. GOSUB 460 must be changed to GOSUB 490 in both places to correctly toggle the read/write operation. Additionally, when I tried this controller on Game Show, I found that it would read track \$00 fine, but would bomb on track \$01. Noting that the bomb occurred as Super IOB was trying to read sectors \$0F to \$0D, I researched the documentation on the copy program. I discovered in the binary file, IOB.OBJ, that after a track was read or written, the sector number would be reset to \$0F (15). This is necessary for DOS 3.3, but for DOS 3.2, it should be \$0C (12)! Thus a one byte patch must be made. \$0F should be changed to \$0C at address \$384. Note that this is accomplished in the controller in line 1011.

Here is the modified DOS 3.2 Controller, CON.13. Note that line 1012 includes 4 POKES that I used to copy Game Show by Computer Advanced Ideas. These turn off the error checks for the first bytes of the address and data markers, the read error flag and data checksum. I was successful, by the way, in accessing all files of Game Show, but as yet have still not made a runnable version, converted to DOS 3.3. However, from the extensive research I had to do, I finally composed Params for Copy II Plus that would faithfully and reasonably quickly make a protected copy.

### Controller

```

1000 REM DOS 3.2 CONTROLLER
1010 TK = 0:LT = 35:ST = 12:LS = 12:CD
= WR:FAST = 1
1011 GOSUB 360: REM SWAP RWTS ROUTINES
TO MAKE MODIFICATIONS
1012 POKE 900,12: REM 13 SECTOR PATCH
IN IOB.OBJ
1013 POKE 47480,0: POKE 47370,0: POKE
47459,24: POKE 47439,0: REM DOS 3.2
RWTS PATCHES
1014 GOSUB 360: REM SWAP RWTS ROUTINES
AGAIN
1020 GOSUB 360: GOSUB 490: GOSUB 610
1030 GOSUB 360: GOSUB 490: GOSUB 610:
IF PEEK (TRK) = LT THEN 1050
1040 TK = PEEK (TRK):ST = PEEK (SCT):
GOTO 1020
1050 HOME:PRINT "COPY-DONE":END
10010 PRINT CHR$(4)
"BLOAD-RWTS.13,A$1900"
```

### Checksums

```

1000-$356B 1013-$C8FE 1040-$83C2
1010-$135A 1014-$917B 1050-$6B2F
1011-$184E 1020-$7C36 10010-$EF46
1012-$13F5 1030-$4EA2
```

Bitkey for...

### Game Show

#### Advanced Ideas Inc.

The Game Show is a delightful quiz game based upon numerous TV game shows. It features a moderator and one or two panelists and an extensive selection of questions in many categories. For a 1982 program, the graphics are good.

Bit copies of this program are produced very slowly and are very unreliable. Most bit copiers will not even copy it. For this reason, I have devoted a great deal of effort whenever I could obtain time over a time of several months. There are several layers of protection which have made my attempts frustrating. Some of the more important protection methods found are:

1. The disks are all in DOS 3.2 format.
2. The program disk has altered prologues: I found address and data prologues of FE AA B5 and FE AA AD, respectively, on tracks \$01-\$10, \$12-\$13 and D5 AA B5 and D5 AA AD on tracks \$11 and \$14-\$22. Track \$00 was a nightmare. Sector \$00 is DOS 3.3 having normal prologues. However, a gibberish sector appears if DOS 3.3 marks are used. Sectors \$01-\$09 have normal

prologues (D5 AA B5 and D5 AA AD), whereas sectors \$0A-\$0C are changed to FE AA B5 and FE AA AD.

3. At least 2 sectors on the program disk have data checksum and data epilogue errors.

4. There are two catalogues, one on Track \$11, the other on Track \$08. A routine starting at \$A800 in the disk's DOS is called to switch prologue bytes and track numbers in order to access both catalogues.

5. Machine language routines, mainly for graphics, are loaded into \$800-\$FFF and \$1800-\$1FFF when the disk is booted and are not shown in the catalogue.

6. Instead of using Applesoft programs, this disk uses Integer Basic. This is really a problem, as Integer Basic is not manipulated in RAM as an Applesoft program might. Instead of running low in memory at \$801, Integer runs high in memory. Variable manipulation is also quite different.

Considering the above, I was able to produce a DOS 3.3 copy of GAME SHOW that, of course, would not boot, using CON.13, the included controller. Note that a special RWTS, RWTS.13, must be used in this swap controller. In order to obtain this, I used Computist's method from v.13, p.27. I then used FID to transfer files from the copied disk's T\$11 to an initialized DOS 3.3 disk. In order to copy the Integer files on T\$08, I booted up an old DOS 3.3 master to obtain the Integer Basic prompt, and changed the catalog track with a POKE 44033,8. In turn, I loaded the files from the copied disk and after changing back to the normal track (POKE 44033,11), I saved them on to the disk with the FIDed files. At this point, I even went so far as to transfer the necessary Integer files from the system master, and made a HELLO file to provide Integer Basic on this disk.

Inspection of the Integer files, and the realization that several machine language routines not in the catalog were being accessed, convinced me that I would never, not in a hundred years, be able to convert this program into a runnable DOS 3.3 environment!

I now was almost stymied until I realized that my knowledge of the marker changes could be used to provide a PARM for Copy II Plus that would provide a good copy, though it would still retain its protection. With this in mind, I planned a PARM that would sector copy all tracks but T\$00. As T\$00 had a combined DOS 3.2/3.3 format and extensive prologue changes, I decided that it should be bit copied. PARM GS.1 can be entered into any recent version of Copy II Plus and will faithfully copy the program side. PARM GS.2 will copy any data diskette.

### PARAM GS.1

```

GAME SHOW * (CAI)
T0
T11, SECTOR COPY, 59=B5, 6B=00, 65=00,
77=00
T14-T22, SECTOR COPY
T1-T10, SECTOR COPY, 57=FE, 61=FE
T12-T13, SECTOR COPY
```

### PARAM GS.2

```

GAME SHOW-DATA * (CAI)
T0-T22, SECTOR COPY, 59=B5, 6B=00, 65=00,
77=00
```

Softkey for...

### Computer Inspector v1.0

#### MECC 1988

This MECC disk has the data prologue altered from D5 AA AD to D5 AD AA. I used COPY A and a sector editor to produce a copyable backup.

1. Run COPY A and then stop it to make some mods.
- ```

RUN COPY A
Ctrl C
70
CALL -151
B8F3:00 turn off check for byte 2 of data prologue
B8FE:00 turn off check for byte 3 of data prologue
ctrl C
RUN
```

2. Sector edit:

| Trk  | Sct  | Byte(s) | From | To |
|------|------|---------|------|----|
| \$00 | \$0B | 99      | AD   | AA |
|      |      | A3      | AA   | AD |
|      | \$0C | 82      | AD   | AA |
|      |      | 87      | AA   | AD |

Enjoy!

Softkey for...

### Comment Dit-On?

#### Lingo Fun, Inc.

After first checking this disk out for changed address and data markers, I found that track \$03 was sectorless and track \$11, the catalogue track, had epilogue bytes changed to D5 AA from DE AA. Accessing the catalog, I was interested to find 2 files that triggered my memory. These files were SSPROT\$A and SSPROT\$1, used in protection many times before. Researching old COMPUTIST editions, I noted the resemblances between the protection on Comment Dit-On and on Walt Disney's Cartoon Maker, softkeyed by Edward Teach in v.51, p.28. Though some minor details were different, the technique of protection

shown was remarkably similar. I found that: - track \$03 is unreadable and likely a nibble count track.

- track \$11 has minimally altered epilogues
- Byte 01 of T\$11 S\$00 is 00 and should be 11 to access the catalogue.
- The HELLO file BRUNs SSPROT\$1 to check before proceeding.
- Another file (the real HELLO program) is not mentioned in the catalogue, but can be found with patience.

On Track \$12, sector \$0F, I discovered the T/S list of the real HELLO file that runs after SSPROT\$1 has done its dirty work. I decided to simply exchange this 4 sector file in the catalogue for the 2 sector file that calls the protection. Here is the method.

1. INIT both sides of a disk with HELLO, deleting the file afterwards.
2. Copy both sides of the original disk with a fast copy program that will ignore track \$03 errors. As we need the VTOC and catalogue on track \$11, make sure to change DOS 3.3 first by poking \*B942:18 to ignore the epilogue errors on track \$11.
3. Sector edit both sides of the copied disk:

### Side one:

| Trk  | Sct  | Byte(s) | From | To |
|------|------|---------|------|----|
| \$11 | \$00 | 01      | 00   | 11 |
|      | 0B   | DD      | 21   | 12 |
|      |      | FE      | 02   | 04 |

(swap HELLOs)

### Side two:

| Trk  | Sct | Byte(s) | From | To |
|------|-----|---------|------|----|
| \$11 | 00  | 01      | 00   | 11 |
|      | 0E  | 97      | 1B   | 12 |
|      |     | B8      | 02   | 04 |

4. Boot DOS 3.3 and turn off error check in DOS. POKE 47426,24  
BRUN FID
5. Transfer all files from the altered copied disk to both sides of your initialized disk.

Softkey for...

### 2400 AD

#### Origin

I have noted that the type of protection on this disk has received considerable attention and would like to express the idea that the elaborate approaches to deprotection are somewhat of an overkill. Specifically, when address prologues are alternated, D5 AA 96 for even tracks and D4 AA 96 for odd tracks, all that needs to be done is to turn off the check for the first address byte in DOS 3.3 and use COPY A.

1. Start COPY A.
- ```

RUN COPY A
ctrl C
70
CALL-151
B957:00 turn off check for 1st address prologue
byte
ctrl C
RUN
back to basic
copy both sides
```

Softkey for...

### Magic Slate v1.3

#### Sunburst

In COMPUTIST v.49, p.26, I commented upon v1.2.3 and noted the moved, but almost identical to the original, protection. Again in v1.3, the routine has been moved. Here is the updated copy method for the 20 and 40 column programs.

1. Boot PRODOS
- ```

BLOAD MS,TSYS,A$2000
CALL-151
2053:EA EA EA was 4C 2F 21
205B:EA EA EA was 4C 2F 21
BSAVE MS, TSYS, A$2000, L$3DEC
2. Repeat step 1 for other side.
```

Softkey for...

### French: Verb Pairs and Idioms

#### Language Study Software

The data epilogues are changed from DE AA to DE DE in the minimal protection observed.

1. Boot a DOS 3.3 disk. Place a blank disk in the drive and initialize a slave disk.
- ```

INIT HELLO
DELETE HELLO
```
2. Get rid of some error checking and use FID to transfer all files to the initialized disk.
- ```

POKE 47426,24
BRUN FID
```

Softkey for...

### Sports Stats

#### MECC.

Having deprotected many MECC disks in the past, I was expecting to spend perhaps 5 minutes to manage Sports Stats, a 1985 program. At first, the only protection visible was changed address prologues (AA D5 96 instead of D5 AA 96) and changed data prologues (D5 AD AA instead of D5 AA AD). So, following usual procedure, I booted the disk, waited until the Applesoft prompt appeared and hit <RESET> several times. I moved

the RWTS down (\*1900<B800.BFFFM) and continued by installing the MECC swap controller and using SUPER IOB to produce a COPY A-able disk. After scanning Track \$00, I edited a few bytes so that only legitimate prologue bytes would appear in the MECC DOS3.3 and then booted my copy.

Darn! The disk booted, but crashed after the menu appeared. Something was different in the copy protection! I also noted that the MECC logo was quite different from all others that I had seen before. After considerable further investigation, I found that the program used a CALL (CALL 30464,1 (or 2)) to a binary file, MECC FLIPPER, to switch prologue bytes so that both the original protected disk and an unprotected data disk could be accessed. To further complicate matters, each time a disk was read, it was checked for whether it was a protected, or an unprotected disk. Simply altering the MECC FLIPPER program to not exchange bytes was insufficient; I had to modify the BASIC programs to ensure that the disk checks were made, but without the checks for whether the disk was protected or not. Here then is the method:

1. Boot the original disk and hit <RESET> several times to stop the drive.

### CALL-151

**1900<B800.BFFFM** move the RWTS down

2. Boot a DOS 3.3 disk without a HELLO program
- ```

BSAVE SPORTS.RWTS, A$1900, L$800 Save RWTS
```

3. Install the MECC Swap Controller into Super SIOB and copy the original to a blank disk.
4. Make the following sector edits:

Trk	Sct	Byte(s)	From	To
\$00	\$02	\$58	AD	AA
		\$5F	AA	AD
		\$F1	AD	AA
		\$FC	AA	AD
\$00	\$03	\$55	AA	D5
		\$5F	D5	AA
\$00	\$06	\$7A	AA	D5
		\$7F	D5	AA

5. Boot DOS 3.3 and insert copied disk.
- ```

BLOAD MECC FLIPPER
CALL-151
7709:60 was A5, aborts prologue switches ctrl C
```

```

UNLOCK MECC FLIPPER
BSAVE MECC FLIPPER, A$7700, L$CD
LOCK MECC FLIPPER
```

### LOAD HELLO-OPTIONS UNLOCK HELLO-OPTIONS

```

2110 ONERR GOTO 2130
2120 GOSUB 500:PRINT D$"VERIFY
DELETIONS"
2130 IF PEEK(222) = 6 THEN PD = 0:
GOTO 3110
4610 ONERR GOTO 4625
4620 PRINT D$"VERIFY DELETIONS,D"DR:
GOTO4670
4625 IF PEEK(222) = 6 THEN PD = 0: GOTO
5000
```

### SAVE HELLO-OPTIONS LOCK HELLO-OPTIONS

### LOAD STIX V52 UNLOCK STIX V52

```

3508 ONERR GOTO 3512
3511 PRINT C$"VERIFY DELETIONS,D"DR:
PD = 1: GOTO 3544
3512 IF PEEK(222) = 6 THEN PD = 0:
GOTO 3544
7271 ONERR GOTO 7274
7273 PRINT CHR$(4)"VERIFY
DELETIONS,D"DR: GOTO 7283
7274 IF PEEK(222) = 6 THEN PD = 1:
GOTO 7295
SAVE STIX V52
LOCK STIX V52
```

### The Mandelbrot Set

No, this is not another softkey; there is no commercial or private domain program called The Mandelbrot Set, to the best of my knowledge. Rather, I wish to take you on a journey into the realm of higher mathematics, non-linear equations and the science of Chaos, the study of the unpredictable.

First, I should tell you how it all began. During March Break this year (I am a high school Physics teacher), I visited a bookstore to buy some books to while away the vacation period. There I came upon a book on sale, with a most unusual title. It was called "CHAOS, Making a New Science" by James Gleick, an editor and reporter at The New York Times. Sensing a bargain, I bought it, and during the Break, I read it and was amazed at the new (to me, at least) approaches to solving problems that heretofore seemed not to be predictable and therefore not solvable (An example might be the dynamics of turbulent stream flow). The book is well written and generally non-mathematical and can be read with pleasure by most curious persons of reasonable intelligence.

Part way through the book is a section that might interest the readers of COMPUTIST. There the work of Benoit Mandelbrot upon the Fractal Geometry of Nature is presented. In 1977, Mandelbrot presented the scientific world with a new approach to the study of some of the convoluted patterns that appear in nature (examples might be the endlessly convoluted outline of a fern frond or the patterns of snowflakes, no two alike!). One pattern produced by Mandelbrot, called the



Mandelbrot Set, is so complex that its appearance on a computer Monitor screen produces awe. The neat thing is that, if any part of the perimeter of this figure is magnified, no matter how much, there is always incredible detail. The perimeter, then is so convoluted that one can only infer that it is infinitely long!

In order to present a graphic image of the Mandelbrot Set on a computer monitor, at least 10 million calculations must be performed. As no one in control of their wits would want to do these computations, the computer is thus the tool to complete the job. Even so, it takes several hours for a BASIC program on an APPLE to do it. Compiling the program reduces the wait to 1 1/2 hours (the Macintosh takes 13 minutes!). Resolution of the finished image on the Hires screen of the Apple II is not nearly as spectacular as when one tries an IBM or Amiga, but is not bad.

To generate this image, one can simply "RUN MANDELBROT.1" or come with me on a journey through mathland as I explain how to calculate it. If you are also interested in seeing a blowup (80X) of the little dot in the far left part of the whole image, then "RUN MANDELBROT.2". For those who have a color monitor, "MANDELBROT.3" presents the image with a multicolored border.

Here is the mathematics of the Mandelbrot Set: The Mandelbrot Set is an image which falls in the range of coordinates X values from -1.9 to +0.5 and Y values from -1.10 to +1.10. Think of the X value as representing a direction on a map. If X is negative, this is towards the west; if X is positive it is directed towards the east. A positive Y value, then is towards the north (or up the monitor screen) and a negative Y value is to the south. In the computer program, one simply tests every coordinate point in the range given in order to see if the point tested lies inside, or outside of the Mandelbrot Set. If the point lies inside, it is plotted; if it lies outside, it will not be plotted.

When one wishes to test a point, say X=0.25 and y=-.53, one simply sets a variable, A to the X value and another variable, B to the Y value. The weird thing, however, is that whereas A is a Real number, B is something mathematicians call an imaginary number. Fear not, for I will explain without confusing anybody.

The way to see how these two types of numbers, and their use is to show a simple statement. The coordinates of each tested point can be represented this way:

$$\begin{matrix} \text{Coordinates of point} = & \text{Real no.} & + & \text{Imaginary no.} \\ & C & = & A & + & B \end{matrix}$$

Using our above example the tested point's formula is:

$$C = 0.25 + -0.53i$$

So to test each point, simply set up the easy formula, with the coordinates placed in their correct place. Now to test the point to see if it fits the Set, take this expression (A + B) and square it, and then add the original expression to the product.

Now if one were dealing with only real numbers, one would get the following: (the product part)

$$(A + B) \times (A + B) = A^2 + 2.AB + B^2$$

and now adding the original expression:

$$(A^2 + 2.AB + B^2) + A + B = A^2 + 2.AB + B^2 + A + B$$

Note if our original seed values were real numbers, we would get:

$$.25^2 + (2 \times .25 \times -.53) + -.53^2 + .25 + (-.53) = .0625 + -.265 + .2809 + .25 - .53 = -.2016$$

But since we are using 1 real number and 1 imaginary number, we have to do something a bit different. You have to know the simple rules of dealing with them. These are the rules:

- 1) Add a real number to another real one gives a real number
- 2) imaginary + imaginary number gives an imaginary number
- 3) real times real number gives a real number
- 4) imaginary times imaginary gives a real negative number!!!

This last rule is the nice one; it provides a link between real and imaginary numbers. Let's use it now in our original example. To make things easier to follow, however, let us put a flag against any number which is imaginary. Thus, the original example of an imaginary number (-0.53) is shown as -.53i. The little "i" then is the identifying flag. Now let's see the coordinate formula:

$$\text{coord.} = A + B$$

giving us:

$$= 0.25 + -0.53i$$

Now square it

$$(.25 + -.53i) \times (.25 + -.53i) = (.25 \times .25) + (.25 \times -.53i) \times 2 + (-.53i \times -.53i) = .0625 + -.265i + -.2809 - .2184 - .265i$$

Note by rule 4 that

$$(-.53i)^2 = -.2809 \text{ (} i \times i = -1 \text{)}$$

Now add the original A + B expression:

$$(-.2184 - .265i) + (.25 + -.53i) = .0316 - .795i$$

To continue the test, you must take this new expression (.0316 - .795i) and square it again and add the ORIGINAL expression to it:

$$(.0316 - .795i) \times (.0316 - .795i) + (.25 - .53i)$$

Do this over and over again, at least twenty times. If during these calculations, the real number or the imaginary number rises above 2 (positive or negative 2), this is a sign that the number will

eventually become infinitely larger, and must therefore lie outside the Mandelbrot Set. The number is therefore discarded and not plotted. But if the numbers never attain a value greater than 2, the coordinate point lies inside the Set and is plotted.

In the program, MANDELBROT.1, lines 70 to 100 set up the Hires screen and adjust the coordinate points to equation and screen values. Line 110 sets the loop to do 20 repeat calculations testing the point. Lines 120 to 140 perform one calculation and line 150 tests the point for size and discards the point if too large by exiting from the loop. If the point passes the test, HCOLOR is set to 3 and it is plotted in lines 160 and 170. If the point does not pass, then HCOLOR is set to 0 and plotted (invisibly). Line 180 loops back to start testing another coordinate.

#### MANDELBROT.1

```
10 REM *****
20 REM * MANDELBROT.1 *
30 REM * BY B.D.BRETT *
40 REM * MAY 18, 1989 *
50 REM *****
60 TEXT : HOME
70 HGR2 :X1 = 180:Y1 = 86
80 FOR X = - 160 TO 40
90 FOR Y = 0 TO 85
100 S = 80:A = X / S:B = Y / S:D = A:E
    = B
110 FOR I = 1 TO 20
120 C = A
130 A = A * A - B * B + D
140 B = 2 * C * B + E
150 HCOLOR= (I > 19) * 3:I = I + ((
    ABS (A) > 2) + ( ABS (B) > 2)) * 20
160 HPLLOT X + X1,Y1 - Y
170 HPLLOT X + X1,Y1 + Y
180 NEXT I,Y,X
190 PRINT CHR$ (7); CHR$ (7): END
```

#### Checksums

|           |            |            |
|-----------|------------|------------|
| 10-\$BADD | 80-\$A1E5  | 150-\$9763 |
| 20-\$9B13 | 90-\$862B  | 160-\$88F5 |
| 30-\$4D3B | 100-\$9BFE | 170-\$488A |
| 40-\$AD92 | 110-\$3996 | 180-\$23DA |
| 50-\$C899 | 120-\$00A6 | 190-\$E044 |
| 60-\$DA01 | 130-\$298A |            |
| 70-\$1D72 | 140-\$6A7F |            |

MANDELBROT.2 shows a magnified view of an obscure "bump" on the east-west line near the left side of the screen. Here I simply set the range over a much smaller range of X & Y values. Note the fine exotic detail persists in this view. Interested programmers may extend the technique to obtain increasingly magnified views that will always show feathery strange detail.

#### MANDELBROT.2

```
10 REM *****
20 REM * MANDELBROT.2 *
30 REM * BY B.D.BRETT *
40 REM * MAY 18, 1989 *
50 REM *****
60 TEXT : HOME
70 HGR2 :S = 3700:T = 6690:U = 90:F = 180
80 FOR X = 10 TO 250
90 X1 = X - T
100 FOR Y = - 90 TO 0
110 Y1 = U + Y:A = X1 / S:B = Y1 / S:D
    = A:E = B
120 FOR I = 1 TO 20
130 C = A
140 A = A * A - B * B + D
150 B = 2 * C * B + E
160 HCOLOR= (I > 19) * 3:I = I + ((
    ABS (A) > 2) + ( ABS (B) > 2)) * 20
170 HPLLOT X, - Y: HPLLOT X,Y + F
180 NEXT I,Y,X
190 PRINT CHR$ (7); CHR$ (7): END
```

#### Checksums

|           |            |            |
|-----------|------------|------------|
| 10-\$BADD | 80-\$758B  | 150-\$6E3F |
| 20-\$9B13 | 90-\$1BEC  | 160-\$A4B2 |
| 30-\$4D3B | 100-\$D769 | 170-\$51B3 |
| 40-\$AD92 | 110-\$653C | 180-\$6AB3 |
| 50-\$C899 | 120-\$1173 | 190-\$7B1B |
| 60-\$DA01 | 130-\$2BDF |            |
| 70-\$9BD2 | 140-\$ECDE |            |

MANDELBROT.3 is a colored variation of MANDELBROT.1. Here, I have plotted points in different colors, inside and outside the Set. I accomplished this by plotting points that failed the test in only one calculation in green, the points failing after 3 calculations in purple, etc., and not plotting the points which passed the test even after 20 calculations.

#### MANDELBROT.3

```
10 REM *****
20 REM * MANDELBROT.3 *
30 REM * BY B.D.BRETT *
40 REM * MAY 18, 1989 *
50 REM *****
60 TEXT : HOME
70 HGR2 :X1 = 180:Y1 = 86
80 FOR X = - 160 TO 70
90 FOR Y = 0 TO 85
100 S = 80:A = X / S:B = Y / S:D = A:E
    = B
110 FOR I = 1 TO 20
120 C = A
130 A = A * A - B * B + D
140 B = 2 * C * B + E
150 HCOLOR= (I > 0) + (I > 3) + (I >
    6) + (I > 9) * 2 + (I > 12) + (I >
    14) - (I = 20) * 3
160 HPLLOT X + X1,Y1 - Y: HPLLOT X +
    X1,Y1 + Y
170 I = I + (( ABS (A) > 2) + ( ABS
    (B) > 2)) * 20
180 NEXT I,Y,X
```

190 PRINT CHR\$ (7); CHR\$ (7): END

#### Checksums

|           |            |            |
|-----------|------------|------------|
| 10-\$BADD | 80-\$A6E6  | 150-\$DE2D |
| 20-\$9B13 | 90-\$9B1C  | 160-\$3E0D |
| 30-\$4D3B | 100-\$ACE3 | 170-\$2B46 |
| 40-\$AD92 | 110-\$3A91 | 180-\$B056 |
| 50-\$C899 | 120-\$0DA1 | 190-\$6BDE |
| 60-\$DA01 | 130-\$288B |            |
| 70-\$1D72 | 140-\$7748 |            |

I compiled these programs, using the Beagle Compiler and ProDOS, and decreased the run-time to about 1 1/2 hours. If uncompiled, the computer should be left on overnight. The same program can be easily adapted to a higher resolution computer (I tried it on a Macintosh and obtained a beautiful result).

For programmers who have taken interest in one-line programs as published in NIBBLE, I have compressed each of the three programs (See MB1.1 LINER, MB2.1 LINER & MB3.1 LINER). I decided to compose these after looking through an old NIBBLE magazine (Aug.,1988) a few days after starting to write this article. There, on page 110, was a one-liner that drew a Mandelbrot Set! My MB3.1 LINER has close similarities to Theodore Yapo's routine, but shows much finer detail than his. An additional benefit of using such one-liners is that they run much, much faster than many line programs. When compiled, you can see a finished product in less than an hour.

#### Mandelbrot.1

```
1 TEXT : HOME : HGR2 :X1 = 180:Y1 =
    86: FOR X = - 160 TO 40: FOR Y = 0
    TO 85:S = 80:A = X / S:D = A:B = Y
    / S:E = B: FOR I = 1 TO 20:C = A:A
    = A * A - B * B + D:B = 2 * C * B +
    E: HCOLOR= (I > 19) * 3:I = I + ((
    ABS (A) > 2) + ( ABS (B) > 2)) *
    20: HPLLOT X + X1,Y1 - Y: HPLLOT X +
    X1,Y1 + Y: NEXT I,Y,X
```

#### Checksums

1-\$4F2D

#### Mandelbrot.2

```
1 HGR2 :S = 3700:T = 6690:U = 90:F =
    180: FOR X = 10 TO 250:X1 = X - T:
    FOR Y = - 90 TO 0:Y1 = U + Y:A = X1
    / S:D = A:B = Y1 / S:E = B: FOR I =
    1 TO 20:C = A:A = A * A - B * B +
    D:B = 2 * C * B + E: HCOLOR= (I >
    19) * 3:I = I + (( ABS (A) > 2) +
    ( ABS (B) > 2)) * 20: HPLLOT X, - Y:
    HPLLOT X,Y + F: NEXT I,Y,X
```

#### Checksums

1-\$98DE

#### Mandelbrot.3

```
1 HGR2 :X1 = 180:Y1 = 86: FOR X = -
    160 TO 70: FOR Y = 0 TO 85:S = 80:A
    = X / S:B = Y / S:D = A:E = B: FOR
    I = 1 TO 20:C = A:A = A * A - B * B
    + D:B = 2 * C * B + E: HCOLOR= (I >
    0) + (I > 3) + (I > 6) + (I > 9) *
    2 + (I > 12) + (I > 14) - (I = 20)
    * 3: HPLLOT X + X1,Y1 - Y: HPLLOT X
    + X1,Y1 + Y:I = I + (( ABS (A) > 2) +
    ( ABS (B) > 2)) * 20: NEXT I,Y,X
```

#### Checksums

1-\$F0F0

### Deprotecting MicroLab Disks (Micro Fun)

For several months, COMPUTIST had a number of MicroLab programs on the most wanted list. I had deprotected four of these about two years ago, but neglected to take notes. As I remembered that they were extensively protected, I have only now found enough time to take another look at them. Here are my results.

Softkey for...

#### Ming's Challenge

##### Micro Fun

Ming's Challenge has a protection somewhat similar to that used for Death in the Caribbean (COMPUTIST v.23 p.9) and Miner 2049'er (COMPUTIST v.22 p.10). Track \$01 is normal, whereas TS01-TS22 have address prologues altered to D3 96 F2, data prologues to 96 D3 E5 and address and data epilogues respectively to D3 B2 and 96 FF. There is a nibble count on TS01, SS09 very much like that of Miner 2049'er, but in a different sector.

Two major differences are shown from previous protection schemes of MicroLab. There is a 2 byte alteration of the translate tables that must be fixed to allow one to read the protected tracks. Another unusual trick found is a minor change in the way marker nibbles are compared to a value in DOS. Instead of directly comparing a nibble (C9 D3 CMP #SD3), in several cases the routine compares with a value placed in page \$00 at \$31 (C5 \$31). The value held in \$31 is changed from one value to another a few times. As this is done outside the RWTS, one cannot use a swap controller to copy the disk. However, a modified controller that will read using the protected disk's prologues and epilogues, as well as the altered translate bytes, will do the job. Several sector edits must also be made. Here are the steps needed to softkey Ming's Challenge:

1. Install the controller, CON.MING listed here into Super IOB and run the resulting program.

When asked whether to format the disk, answer "Y" for yes.

2. The controller will complete sector edits in track \$00 as well as deprotecting the disk. When finished, using a sector editor, an additional 7 edits must be made on TS01, SS09 to disable the nibble count. See the following table:

| Trk  | Sct  | Byte(s) | From | To   |                       |
|------|------|---------|------|------|-----------------------|
| \$00 | \$02 | \$53    | \$96 | \$05 |                       |
|      |      | 58      | D3   | AA   | DOS marker bytes      |
|      |      | 5D      | E5   | AD   |                       |
|      |      | 9E      | 96   | DE   | (edited by Super IOB) |
|      |      | A3      | FF   | AA   |                       |
|      |      | E7      | 96   | D5   |                       |
|      |      | F0      | C5   | C9   |                       |
|      |      | F1      | 31   | AA   |                       |
|      |      | FC      | E5   | AD   |                       |
| \$00 | \$03 | \$35    | 96   | DE   |                       |
|      |      | 3F      | FF   | AA   |                       |
|      |      | 54      | C5   | C9   |                       |
|      |      | 55      | 31   | D5   |                       |
|      |      | 5F      | 96   | AA   |                       |
|      |      | 6A      | F2   | 96   |                       |
|      |      | 90      | C5   | C9   |                       |
|      |      | 91      | 31   | DE   |                       |
|      |      | 9B      | B2   | AA   |                       |
| \$00 | \$06 | 7A      | D3   | D5   |                       |
|      |      | 7F      | 96   | AA   |                       |
|      |      | 84      | F2   | 96   |                       |
|      |      | AE      | D3   | DE   |                       |
|      |      | B3      | B2   | AA   |                       |
| \$00 | \$04 | \$29    | \$05 | \$96 | Translate Tables      |
|      |      | 48      | AA   | D3   | \$BA29-\$BA68 (Write) |
|      |      | AA      | 1F   | AA   | \$BA96-\$BAFF (Read)  |
|      |      | D5      | 00   | D5   | (edited by Super IOB) |
| \$01 | \$09 | \$73    | \$4C | \$EA |                       |
|      |      | 74      | 00   | EA   | Abort nibble count    |
|      |      | 75      | C6   | EA   |                       |
|      |      | 81      | D0   | EA   | (Sector edit these)   |
|      |      | 82      | 0C   | EA   |                       |
|      |      | 89      | D0   | EA   |                       |
|      |      | 8A      | 04   | EA   |                       |

#### Controller

```
1000 REM MING CONTROLLER
1010 TK = 0:LT = 1:ST = 15:LS = 15:CD
    = WR:FAST = 1
1020 GOSUB 490: GOSUB 610
1025 RESTORE :T1 = TK:TK = PEEK (TRK):
    GOSUB 310:TK = T1
1030 GOSUB 490: GOSUB 610: IF PEEK
    (TRK) = LT THEN 1050
1040 TK = PEEK (TRK):ST = PEEK (SCT):
    GOTO 1020
1050 TK = 1:LT = 35:ST = 15:LS = 15:CD
    = WR:FAST = 1
1060 POKE 47426,24: POKE 47406,0: POKE
    47411,106
1070 RESTORE : GOSUB 190: GOSUB 210:
    GOSUB 170: POKE 47786,31: POKE
    47829,0
1080 GOSUB 490: GOSUB 610
1090 GOSUB 230: POKE 47786,170: POKE
    47829,213
1100 GOSUB 490: GOSUB 610: IF PEEK
    (TRK) = LT THEN 1120
1110 TK = PEEK (TRK):ST = PEEK (SCT):
    GOTO 1070
1120 HOME : PRINT "COPY-DONE" : END
5000 DATA 211,150,242
5010 DATA 150,211,229
5020 DATA 211,178,150,255
5030 DATA 27-CHANGES
5040 DATA 0,2,83,213,0,2,88,170
5050 DATA 0,2,93,173,0,2,158,222
5060 DATA 0,2,163,170,0,2,231,213
5070 DATA 0,2,240,201,0,2,241,170
5080 DATA 0,2,252,173,0,3,53,222
5090 DATA 0,3,63,170,0,3,84,201
5100 DATA 0,3,85,213,0,3,95,170
5110 DATA 0,3,106,150,0,3,144,201
5120 DATA 0,3,145,222,0,3,155,170
5130 DATA 0,6,122,213,0,6,127,170
5140 DATA 0,6,132,150,0,6,174,222
5150 DATA 0,6,179,170,0,4,41,150
5160 DATA 0,4,72,211,0,4,170,170
5170 DATA 0,4,213,213
```

#### Checksums

|             |             |             |
|-------------|-------------|-------------|
| 1000-\$356B | 1100-\$E077 | 5080-\$BDD9 |
| 1010-\$EA41 | 1110-\$32A4 | 5090-\$6798 |
| 1020-\$3164 | 1120-\$1B51 | 5100-\$9906 |
| 1025-\$A976 | 5000-\$FDC4 | 5110-\$BADD |
| 1030-\$E423 | 5010-\$381C | 5120-\$DEA8 |
| 1040-\$4642 | 5020-\$01D4 | 5130-\$D843 |
| 1050-\$E17B | 5030-\$2FA3 | 5140-\$65AE |
| 1060-\$2267 | 5040-\$E27D | 5150-\$883B |
| 1070-\$2D08 | 5050-\$AAF5 | 5160-\$C467 |
| 1080-\$F980 | 5060-\$0066 | 5170-\$B4BC |
| 1090-\$1102 | 5070-\$7BC4 |             |

Softkey for...

#### Jigsaw

##### MicroLab

Jigsaw has a similar protection to that of Ming's Challenge. It has protected tracks \$T01-\$T09 with the same changed prologues and epilogues. However, besides TS00, TS0A-TS17 are normal and copyable with any sector copier. TS18-TS22 are unformatted. The translate table is likewise altered for the protected tracks, but there seems to be no nibble count to worry about. MicroLab has not bothered to compare nibbles with the value at \$31 in this disk, so a controller can be easily written, and all sector edits can be made by Super IOB. Here are the softkey steps:

1. Install the controller listed, CON.JIGSAW, into Super IOB and run the resulting program. Answer "Y" when asked whether to format the disk.
2. The following sector edits are performed by Super IOB:

| Trk  | Sci  | Byte(s) | From | To   |
|------|------|---------|------|------|
| \$00 | \$02 | \$E7    | \$96 | \$D5 |
|      |      | F1      | D3   | AA   |
|      |      | FC      | E5   | AD   |
| \$00 | \$03 | \$35    | \$96 | \$DE |
|      |      | 3F      | FF   | AA   |
|      |      | 55      | D3   | D5   |
|      |      | 5F      | 96   | AA   |
|      |      | 6A      | F2   | 96   |
|      |      | 91      | D3   | DE   |
|      |      | 9B      | B2   | AA   |
| \$00 | \$04 | \$29    | \$D5 | \$96 |
|      |      | 48      | AA   | D3   |
|      |      | AA      | 1F   | AA   |
|      |      | D5      | 00   | D5   |

### Controller

```

1000 REM JIGSAW CONTROLLER
1010 TK = 0:LT = 1:ST = 15:LS = 15:CD
= WR:FAST = 1
1012 POKE 775,96: ONERR GOTO 550
1015 GOTO 1020
1018 TK = 10:LT = 24:ST = 15:LS =
15:CD = WR:FAST = 1
1020 GOSUB 490: GOSUB 610
1025 IF LT = 1 THEN RESTORE :T1 =
TK:TK = PEEK (TRK): GOSUB 310:TK =
T1
1030 GOSUB 490: GOSUB 610: IF ( PEEK
(TRK) = LT) AND (LT = 1) THEN 1018
1035 IF PEEK (TRK) = LT THEN 1050
1040 TK = PEEK (TRK):ST = PEEK (SCT):
GOTO 1020
1050 TK = 1:LT = 10:ST = 15:LS = 15:CD
= WR:FAST = 1
1060 POKE 47426,24: POKE 47406,0: POKE
47411,106
1070 RESTORE : GOSUB 190: GOSUB 210:
GOSUB 170: POKE 47786,31: POKE
47829,0
1080 GOSUB 490: GOSUB 610
1090 GOSUB 230: POKE 47786,170: POKE
47829,213
1100 GOSUB 490: GOSUB 610: IF PEEK
(TRK) = LT THEN 1120
1110 TK = PEEK (TRK):ST = PEEK (SCT):
GOTO 1070
1120 HOME : PRINT "COPY-DONE" : END
5000 DATA 211,150,242
5010 DATA 150,211,229
5020 DATA 211,178,150,255
5030 DATA 14-CHANGES
5040 DATA 0,2,231,213,0,2,241,170
5050 DATA 0,2,252,173,0,3,53,222
5060 DATA 0,3,63,170,0,3,85,213
5070 DATA 0,3,95,170,0,3,106,150
5080 DATA 0,3,145,222,0,3,155,170
5090 DATA 0,4,41,150,0,4,72,211
5100 DATA 0,4,170,170,0,4,213,213

```

### Checksums

|             |             |             |
|-------------|-------------|-------------|
| 1000-\$356B | 1050-\$083E | 5020-\$963D |
| 1010-\$EA41 | 1060-\$6704 | 5030-\$0882 |
| 1012-\$3D28 | 1070-\$D811 | 5040-\$A4E9 |
| 1015-\$E82D | 1080-\$BCE3 | 5050-\$1CD7 |
| 1018-\$6D0A | 1090-\$58F5 | 5060-\$60FE |
| 1020-\$DE79 | 1100-\$F384 | 5070-\$9DFD |
| 1025-\$74B1 | 1110-\$A54D | 5080-\$7E0D |
| 1030-\$BBCC | 1120-\$0296 | 5090-\$CA91 |
| 1035-\$0D66 | 5000-\$6A2D | 5100-\$DED1 |
| 1040-\$0FB5 | 5010-\$7D7F |             |

## Jim S. Hart NC

### Softkey for... Math Blaster Mystery Davidson

**Requirements:**  
4 blank disk sides  
Whole disk copy program that will ignore read errors  
ProDOS 8 and BASIC.SYSTEM  
Optional - for putting all four sides on one 3.5" disk  
Disk searcher/block editor  
ProDOS utility program

Math Blaster Mystery is a very good educational program. Students are taught the thought processes to go through in solving math problems. Once a student becomes well versed in such processes, the intermediate problem solving steps can be passed over, and the student can concentrate on answering the questions. All in all, this 4 disk sided program is a quality product. Of course, it's copy protected. The copy protection involves an 'unformatted track', as well as nibble counting. Cookbook instructions are at the end of the article for the impatient.

### The Protection

Attempting to fast copy the four sides using the Locksmith fast copy program reveals that all sides are normal except for side one. Track \$22 of side one is 'unformatted'. Hmm. It's very unusual for a non-copy protected disk to have an unformatted track, so I was lead to believe the disk was copy protected. I tried to boot up the copy of the first disk (the side with the unformatted track). The ProDOS copyright message came up and then a second later I was staring at the ProDOS quit code. The ProDOS quit code is a section of code that resides within ProDOS to allow a standard exit from all ProDOS programs. The one normally built into ProDOS is very unwieldy, hence the proliferation of program selectors like Bird's Better Bye or Squirt. These two programs replace the quit code and are mini program selectors. I have Bird's Better Bye installed in all of my ProDOS' - it's that good. I

recommend buying a Beagle Bros product just so you can get it. Anyway, I was staring at the original ProDOS quit code. A program does not normally do this unless maybe a copy protection scheme was not satisfied? Well, that turns out to be the reason. When a ProDOS disk is booted, the first two blocks on the disk get loaded in (boot blocks). After they are loaded and control passes to them, they immediately look for a file named PRODOS in the root directory. PRODOS is a system file (type SYS), and it's the ProDOS operating system. Once PRODOS has been loaded and control passes to it, it does some initialization, prints the ProDOS copyright message, and then scans the root directory for a type SYS file whose file name ends with '.SYSTEM' (i.e. BASIC.SYSTEM, UTIL.SYSTEM, etc). If it does not find one, an error message is displayed. If it does find at least one, ProDOS will then load and execute the first file in the root directory with the '.SYSTEM' extension. For example, suppose you have a disk with these files on it:

```

PRODOS 32      SYS
DUMMY.SYSTEM 2      BAS
COMPUTIST     99     SYS
BASIC.SYSTEM  20     SYS
UTIL.SYSTEM   56     SYS

```

When booted, PRODOS gets loaded first. ProDOS then runs BASIC.SYSTEM because it is the FIRST type SYS file that ends with '.SYSTEM'. Looking at a catalog of the first side of Math Blaster Mystery, there is only one other SYS file in the root directory besides PRODOS: PS.SYSTEM. Guess which file gets run first after PRODOS? Remember when I booted the copy earlier and it dumped me into the quit code right after the ProDOS copyright message? That means the first '.SYSTEM' file had to have done it, which means the protection code is in the first '.SYSTEM' file. This is where I booted a ProDOS disk with BASIC.SYSTEM on it and got into BASIC. I inserted side one of the copy and set the prefix to it:

### PREFIX /MBM

Since the PS.SYSTEM file had the protection code in it, I loaded the file to look it over:

### BLOAD PS.SYSTEM, A\$2000, TSYS

SYS files ALWAYS load in at \$2000. Guess where I started looking? Here is a bit of the code there:

### 2000L

```

2000: 20 D2 25 JSR $25D2
2003: 4C 74 08 JMP $0874
2006: 8E 04 C0 STX $C004
2009: 8E 02 C0 STX $C002

```

A subroutine is executed at \$25D2 (Jump to SubRoutine at) and then control passes to \$0874 via a JuMP statement. Since SYS files start loading at \$2000, I found it odd that a jump is made to \$0874. The subroutine at \$25D2 must have a memory move in it somewhere, and it must move memory to around the \$0874 area. Let's take a look at the subroutine at \$25D2:

### 25D2L

```

25D2: A2 00 LDX #00
25D4: BD 03 20 LDA $2003
25D7: 9D 01 08 STA $0801
25DA: BD 03 21 LDA $2103
25DD: 9D 01 09 STA $0901
25E0: BD 03 22 LDA $2203
25E3: 9D 01 0A STA $0A01
25E6: BD 03 23 LDA $2303
25E9: 9D 01 0B STA $0B01
25EC: BD 03 24 LDA $2403
25EF: 9D 01 0C STA $0C01
25F2: BD 03 25 LDA $2503
25F5: E8 INX
25F6: D0 DC BNE $25D4
25F8: 60 RTS

```

Well, we've found the memory move. Since it is a stand alone subroutine, let's execute it so the code that ends up at \$874 will be moved to \$874:

### 25D2G

The code has been moved, so let's take a look to see what is at \$874:

### 874L

```

874: 20 C8 0A JSR $0AC8
877: F0 D9 BEQ $0852
879: AD 98 BF LDA $8F98

```

The first thing to notice is that a subroutine call to \$0AC8 is executed. Right after that, the zero flag is checked. If there was a zero result in the subroutine, the BEQ (Branch on Equal result) will be taken and control will transfer to \$0852. A look at the code at \$0852 reveals:

### 0852L

```

0852: 8E 04 C0 STX $C004
0855: 8E 02 C0 STX $C002
0858: 20 00 BF JSR $BF00
085B: 65
085C: 5E 08

```

Ah ha! This is where reference material like Beneath Apple ProDOS and back issues of Computist come in handy. The JSR \$BF00 is a ProDOS machine language interface (low level operating system) call. The first byte after it is the type of call (65 = QUIT CODE!) and the next two bytes are the location of the call parameters.

What's important is that we have just found the quick quit code call I was experiencing on the copied disk. We don't want the quit code to be called (failed protection check = quit code call). Where was the quit code called from? Well, remember the code that started at \$874? Notice the BEQ \$0852? We DO NOT WANT this branch to be taken. Taking that branch means that the protection code at \$0AC8 failed. Now, how do we circumvent it? There are a number of ways. We could taken out the call to the protection (JSR \$0AC8), follow the protection code and alter it so it always reports a successful check, or simply get rid of the branching command (BEQ \$0852). I decided to take the simple way out and NOP the branch. I changed the code at \$0874 to this:

```
877:EA EA (was F0 D9)
```

### 874L

```

0874: 20 0A C8 JSR $0AC8
0877: EA NOP (was F0)
0878: EA NOP (was D9)

```

NOPs in machine language have the same function as REMs in BASIC: do nothing. I made this change and saved the file back to the copied disk:

### BSAVE PS.SYSTEM,A\$2000,TSYS

Booting the first side now results in no quit code and a functioning program. The protection check has been taken care of.

### Putting it all on one 3.5" disk

One final thing bothered me. The 4 floppy disks are in ProDOS format, so why couldn't they all be put on one 3.5" disk? Trying to do so will initially give you nothing but frustration. There is a free upgrade offer included with the package, but why wait? If we can deprotect it, we can fix it to run on a 3.5" disk. The problem that the program uses absolute prefixes instead of relative ones. For example, it expects to find a disk named '/MBM2' when it needs the files from side two. Now, if we could change it so that instead of looking for a DISK named '/MBM2', it would look in a SUBDIRECTORY named AMBM2, our problems would be solved. Why use 'AMBM2' in place of '/MBM2'? AMBM2 has as many characters as /MBM2 and to convert /MBM2 to AMBM2 only requires that you change the '/' to a 'A'. Boot up your disk searcher/block editor (I used Copy II Plus) and read block \$7 of the copied first side of disk one. Now search for the HEX sequence:

```
4D 42 4D 32
```

Those are the hex values for the characters 'MBM2'. When you find them, you will also see the other disk's names and subdirectory names, for example:

```

/MBM2/. /MBM3/. /MBM4.
/MBM2/DATA. /MBM4/DATA.

```

or something very similar. These are the pathnames the program uses to load its files. Here is where we make our changes. For example, if we change '/MBM2/' to 'AMBM2/', then the program will look in a subdirectory 'AMBM2/' instead of a disk '/MBM2/' for its files. The steps to put all of the floppies onto one 3.5" disk are in the cookbook section. This procedure can be applied to many other ProDOS based programs that have their pathnames hard coded into them. One other program this works for is the ProDOS version of Sensible Speller. Enjoy!

### Part 1 - The softkey

1. Fast copy all four original disk sides onto the four blank sides. Ignore errors on disk #1, side #1.
2. Boot up ProDOS and get into BASIC.
3. Insert disk #1, side #1 into a disk drive and type:

### PREFIX /MBM

4. Load up the main system file:  
**BLOAD PS.SYSTEM, A\$2000, TSYS**

5. NOP out the branch:

```
2079:EA EA was F0 D9
```

6. Save the deprotected file back to disk:

### BSAVE PS.SYSTEM, A\$2000, TSYS

The deprotection is complete!

### Part 2 - Putting it all on a 3.5" disk

1. Boot up your ProDOS utility program (I used Copy II Plus).
2. Format a 3.5" disk and name it /X.
3. Copy all of the files from disk #1, side #1 onto /X.
4. Make four subdirectories on /X and name them

```

AMBM2
AMBM3
AMBM4

```

A catalog of the disk will look like this:

```

/X-----AMBM2
|
|-----AMBM3
|
|-----AMBM4

```

5. Copy the files from disk #1, side #2 to /X/ AMBM2/.

6. Copy the files from disk #2, side #1 to /X/ AMBM3/.
7. Copy the files from disk #2, side #2 to /X/ AMBM4/.
8. All of the files from the first side should be in the main directory, and all of the files from the other sides should be in their own subdirectories now. Boot your disk searcher/block editor.
9. Read in block \$7.
10. Search the disk for the HEX sequence 4D 42 4D 32. When you find it, you should see the names of the other disks in the ASCII section of your block editor. Make the following changes:

| CHANGE         | TO             |
|----------------|----------------|
| 2F 4D 42 4D 32 | 41 4D 42 4D 32 |
| 2F 4D 42 4D 33 | 41 4D 42 4D 33 |
| 2F 4D 42 4D 34 | 41 4D 42 4D 34 |

You are changing the '/' in front of the disk names into the letter 'A'. Don't forget to change ALL occurrences of the above bytes in the block. There will be two occurrences of the first and third sequence of bytes.

11. Write the block back to disk.

Your Math Blaster Mystery program is now all on one 3.5" disk! To speed things up even more on a GS, boot the disk after you've installed Diversi-Cache. It speeds disk accessing by 300% or more.

Softkey for...

## California Games GS Epyx

**Requirements:**  
A blank formatted 3.5" disk  
3.5" disk copy program  
Block editor/disk searcher

I tried out Dan Halfwit's California Games GS softkey in Computist #64 and it didn't work all the way for me. I checked the block he spoke of (\$FC) and compared his 'TO' bytes to what was on my disk. It seems some of the code moved around a little, but the protection still is there.

1. Copy the original disk onto the blank formatted 3.5" disk.
2. Using your block editor, make the following changes to the copied disk:

| Blk  | Byte(s) | From  | To    |
|------|---------|-------|-------|
| \$FC | \$66    | 22    | AF    |
|      | \$77-78 | 90 03 | 80 03 |
|      | \$88    | 22    | AF    |
|      | \$9C    | 90 03 | 80 03 |
|      | \$B9    | 90 1D | 80 18 |

3. Write the block back to disk and you're done!

### The Protection Scheme

Below is a partial listing of the protection scheme. I've sent it in so readers can have something to look at and compare to when they go about looking for a GS protection scheme.

### [Block \$FC]

|                   |            |                             |
|-------------------|------------|-----------------------------|
| 115A: A2 20       | LDX #20    | ;track \$20                 |
| 115C: A0 01       | LDY #01    | ;side 1                     |
| 115E: 5A          | PHY        |                             |
| 115F: DA          | PHX        |                             |
| 1160: F4 00 00    | PEA 0000   |                             |
| 1163: F4 AA 52    | PEA 52AA   |                             |
| 1166: 22 93 53 00 | JSL 005393 | ;call nibble count routine  |
| 116A: 8E 9E 52    | STX 529E   |                             |
| 116D: 8C 9F 52    | STY 529F   |                             |
| 1170: A8          | TAY        |                             |
| 1171: 68          | PLA        |                             |
| 1172: 68          | PLA        |                             |
| 1173: 68          | PLA        |                             |
| 1174: 68          | PLA        |                             |
| 1175: 68          | PLA        |                             |
| 1176: 68          | PLA        |                             |
| 1177: 90 03       | BCC 117C   | ;good nibble count if taken |
| 1179: 4C 93 52    | JMP 5293   | ;crash                      |
| 117C: A2 21       | LDX #21    | ;track \$21                 |
| 117E: A0 01       | LDY #01    | ;side 1                     |
| 1180: 5A          | PHY        |                             |
| 1181: DA          | PHX        |                             |
| 1182: F4 00 00    | PEA 0000   |                             |
| 1185: F4 AA 52    | PEA 52AA   |                             |
| 1188: 22 93 53 00 | JSL 005393 | ;call nibble count routine  |
| 118C: 8D D0 52    | STA 52D0   |                             |
| 118F: 8E A4 52    | STX 52A4   |                             |
| 1192: 8C A5 52    | STY 52A5   |                             |
| 1195: A8          | TAY        |                             |
| 1196: 68          | PLA        |                             |
| 1197: 68          | PLA        |                             |
| 1198: 68          | PLA        |                             |
| 1199: 68          | PLA        |                             |
| 119A: 68          | PLA        |                             |
| 119B: 68          | PLA        |                             |
| 119C: 90 03       | BCC 11A1   | ;good nibble count if taken |
| 119E: 4C 93 52    | JMP 5293   | ;crash                      |
| 11A1: C2 30       | REP #30    |                             |
| 11A3: 22 76 53 00 | JSL 005376 |                             |
| 11A7: 28          | PLP        |                             |
| 11A8: FB          | XCE        |                             |
| 11A9: 28          | PLP        |                             |
| 11AA: 08          | PHP        |                             |
| 11AB: 18          | CLC        |                             |
| 11AC: FB          | XCE        |                             |
| 11AD: 08          | PHP        |                             |

11AE: C2 30 REP #30  
 11B0: A0 FF FF LDY #FFFF  
 11B3: AD 9E 52 LDA 529E  
 11B6: CD A0 52 CMP 52A0  
 11B9: 90 1D BCC 11D8 :bad  
 11BB: AD 9E 52 LDA 529E  
 11BE: CD A2 52 CMP 52A2  
 11C1: B0 15 BCS 11D8 :bad  
 11C3: AD A4 52 LDA 52A4  
 11C6: CD A6 52 CMP 52A6  
 11C9: 90 0D BCC 11D8 :bad  
 11CB: AD A4 52 LDA 52A4  
 11CE: CD A8 52 CMP 52A8  
 11D1: B0 05 BCS 11D8 :bad  
 11D3: 28 PLP  
 11D4: FB XCE  
 11D5: 28 PLP  
 11D6: 18 CLC  
 11D7: 60 RTS  
 11D8: C2 30 REP #30 :come here if count was bad

The changes I made were:

| original                     | from:to   |
|------------------------------|-----------|
| 1166: 22 93 53 00 JSL 005393 | 22:AF LDA |
| 1177: 90 03 BCC 117C         | 90:80 BRA |
| 1188: 22 93 53 00 JSL 005393 | 22:AF LDA |
| 119C: 90 03 BCC 11A1         | 90:80 BRA |
| 11B9: 90 1D BCC 11D8         | 90:80 BRA |

The changes at 1166 and 1188 disabled the calls to the nibble counts. The changes at 1177 and 119C jumped over a crash routine call. Finally, the change at 11B9 jumps over a whole bunch of checks and just goes to where the code would go if the nibble count had been successful.

### A Collection of short softkeys

Softkey for...

#### Antonyms & Sentence Completion (Best sentences)

Queue Intellectual Software

#### Analogy - Advanced I & Advanced II

Hartley

#### Requirements:

1 blank disk  
 Super IOB v1.5  
 New Swap controller  
 RWTS WORM from Computist #61

1. Boot normal DOS 3.3 and load up the RWTS WORM:

#### BLOAD RWTS WORM, A\$9500

2. Insert original disk into slot 6 drive 1 and execute the WORM:

#### CALL 38144

3. After a few seconds the RWTS will be in memory at \$1900. Take out the original disk, insert your Super IOB disk, and save the RWTS:

#### BSAVE RWTS.rwts name, A\$1900, L\$800

4. Install the New Swap controller into Super IOB and then make the following change:

```
1015 TK = 3
10010 PRINT CHR$(4) "BLOAD RWTS.rwts
name, A$1900"
```

5. RUN the controller and when it is done, your disk will be deprotected.

Softkey for...

#### Reading Professor

Executive Systems, Inc.

#### Requirements:

3 blank disks  
 COPYA  
 Sector editor

1. Boot DOS 3.3, disable error checking, and run COPYA:

#### POKE 47426,24 RUN COPYA

2. Copy all three disks onto the blanks.  
 3. On the Reading Professor disk, make the following sector edits so that the disk can read itself:

| Trk  | Sec  | Byte(s) | From  | To    |
|------|------|---------|-------|-------|
| \$00 | \$03 | 36-37   | D0 0A | 18 EA |
|      |      | 92-93   | D0 0A | 18 EA |

4. Write the sector back to disk and you are done!

The edits (and the POKE 47426,24) were necessary because some of the sectors on track \$03 are different from standard DOS 3.3.

Softkey for...

#### Word Puzzles for Creative Teaching

EBSCO Curriculum Materials

#### Requirements:

Blank disk  
 Super IOB  
 New Swap controller  
 RWTS WORM from Computist #61  
 Fast DOS 3.3 (optional)

On the original disk's sleeve, there is a label

I thought you might be interested in reading:

"This disk is copy protected. Attempts to copy will cause data to be altered, and will void replacement guarantee"

Well, here is a better replacement 'guarantee': Computist! Follow the steps below to guarantee you won't have to call EBSCO for a replacement disk.

1. Boot up DOS 3.3 (a fast DOS is preferable) and initialize the blank disk:

#### INIT HELLO

2. Load up the RWTS WORM:

#### BLOAD RWTS WORM, A\$9500

3. Insert the original disk and activate the WORM:

#### CALL 38144

4. Insert your Super IOB disk and save the RWTS:

#### BSAVE RWTS.EBSCO, A\$1900, L\$800

5. Install the New Swap controller into Super IOB and make the following changes:

```
1015 TK = 3
10010 PRINT CHR$(4) "BLOAD RWTS.EBSCO,
A$1900"
```

6. RUN the controller to copy the original onto the newly formatted disk.

You're done! Now, you don't have to live with EBSCO's 'guarantee' any more.

Softkey for...

#### Microcomputer Study Guide - Fundamental Accounting Principles, Chapters 1-14 & 15-28

Richard D. Irwin, Inc.

#### Requirements:

4 blank disks (or 2 disks that are double sided)  
 Whole disk copier  
 Disk searcher/sector editor

The protection on these four sides is the exact same as on KC's Deals On Wheels (softkey in Computist #46). Refer to that article for an explanation.

1. Use your whole disk copy program to copy all four sides onto the blank four sides.

2. Boot up your disk searcher/sector editor and search for 2C E9 C0, replace with 18 90 5A. Make the changes to each of the four sides. There are two such edits to be made on each disk side, and they are usually within a track of each other. Mine were on tracks \$0F and \$10, but yours may be different, so scan for them.

3. Write the changed sectors back to disk and you're done!

Softkey for...

#### Multiscribe v3.0

Claris Corp.

1. Copy the original disk with any whole disk copier.

2. Scan the copied disk for A2 00 B5 00 9D 00 BA CA D0 F8 and change it to A9 00 18 60 9D 00 BA CA D0 F8.

3. Write the change back to disk and you're done.

Softkey for...

#### Starglider

Rainbird/Firebird Software

#### Requirements:

A blank 5.25" disk  
 Whole disk copy program such as COPYA  
 Sector editor/disk searcher  
 A fast DOS (optional)

#### Removing the manual check

In Computist #64, Edward Croft Jr. had a softkey for Starglider. I thought back because I had cracked this program a long time ago and had (gasp) forgotten to send the crack in to Computist! Well, my way is different from Ed's in the sense that it removes the manual check so that it doesn't even ask you any more.

1. Copy the original Starglider disk onto the blank disk using your whole disk copy program. To speed things up, copy a fast DOS onto the first three tracks.

2. Get out your sector editor and make the following edit to your copied Starglider disk:

| Trk  | Sec  | Byte(s) | From     | To       |
|------|------|---------|----------|----------|
| \$0F | \$0F | A0-A2   | 20 00 60 | EA EA EA |

3. Write the sector back to disk. You're done!

#### The Protection Scheme

Below is a listing of the code around the call to the password protection in case yours is in a different spot. I found the code by following the files in the order that they were executed.

#### Track \$0F, sector \$0F

```
008C: 20 28 42 JSR 4228
008F: C9 01 CMP #01
0091: D0 03 BNE 0096
0093: 20 E6 41 JSR 41E6
```

```
0096: 18 CLC
0097: 69 01 ADC #01
0099: C9 04 CMP #04
009B: D0 0F BNE 00AC
009D: 8D 8B 41 STA 418B
00A0: 20 00 60 JSR 6000 password check
00A3: 20 D9 41 JSR 41D9
00A6: 20 E6 41 JSR 41E6
00A9: AD 8B 41 LDA 418B
00AC: C9 07 CMP #07
00AE: 90 DC BCC 008C
00B0: 60 RTS
```

Softkey for...

#### Children's Writing and Publishing Center

The Learning Company

#### Requirements:

Original disks  
 A blank disk for each side  
 COPYA from Apple DOS 3.3 System Master disk

1. Boot up DOS 3.3.

#### POKE 47426,24

#### RUN COPYA

2. Copy all disk sides.

3. On the copy of side #1, load the file with the protection scheme:

#### BLOAD RDOS.AUX

7764:4C F7 77 was A5 DA F0, skip protection

#### BSAVE RDOS.AUX,A\$

You're done.

To Charles Halght: I agree with you on the tabloid format of Computist. It would be fine to receive Computist in that form. The only complaint I have with it is that the front and back covers are exposed. Adding a blank cover page to the front and back wouldn't add any more to the cost and it would protect the magazine better. OPEN-Apple, a monthly magazine from TechAlliance, puts a cover page on both the front and back of their magazine and it really is a nice touch. As for the costs of typesetting equipment, let me pose a possible solution. This is a computer magazine geared primarily towards Apple computers, correct? Why not produce the magazine using a Macintosh? Let's see...\$2300 a month for 6 months comes out to \$13800. That's more than enough to buy a Macintosh system complete with Laserwriter printer. You could completely produce and print the master copy of the magazine "in house". When it comes time to make the copies for the subscribers, the magazine would already be in photo-ready format. You wouldn't need to lease the typesetting equipment anymore which would save money.

Another potential money making venture would be a creation of a book I term "THE COMPUTIST LOG". What this book would consist of are all of the non-deprotection related articles and programs that have been in Computist in past issues. You could even have more than one book. For example, in the Computist Log you could have the articles on modifying the printer drivers in Print Shop & Newsroom, map editors/printers for various games such as mine for Ultima IV, game playing tips, etc. The Log could be divided up into chapters with different chapters each having a different focus, like the above mentioned articles and programs. There could be a chapter (a large one) devoted to nothing else but game tips and hints. Another chapter would contain APTs. Another would contain programs. I think this would be a sought after book once the general computer public were made aware of it. I know I'd buy one of the books to have all of the info in one easy to use reference.

To Gary Verbuch: There definitely are LISP compilers for the Apple // series of computers. Two such compilers are App-L-ISP (\$50) from Special Software Systems and KeyLISP (\$149) from XPrime Corporation. The addresses for the companies are:

Special Software Systems  
 1655 Campbell Ave.  
 Thousand Oaks, CA 91360  
 (805) 494-0040

Xprime Corporation  
 10835 Santa Monica Blvd., Ste. 204A  
 Los Angeles, CA 90025  
 (213) 470-4663

I suggest you join TechAlliance (formerly Apple Programmers and Developers Association). If you are a member, you can get a free guide to languages and tools available for the Apple // and Macintosh computers. There is a lot more out there, compiler wise, for the Apple // series than I suspected.

To Rich Linville: There are several ways to put a DOS 3.3 program from a 5.25" disk onto a 3.5" disk. One choice is to format the 3.5" disk under ProDOS and then copy PRODOS and BASIC.SYSTEM to the disk. Now use your ProDOS disk utility program (I use Copy II Plus) to copy all of the files from the 5.25" disk to the 3.5" disk. This will work quite well if the copied files are all Applesoft. Another choice is to use a modified DOS 3.3. UnoDOS, AMDOS, and UniDOS 3.3 are all DOS 3.3s that have been modified so that they will run on a 3.5" disk. Once

you have formatted the 3.5" disk with one of these DOSs, use the supplied copy program to copy the files from the 5.25" disk to the 3.5" disk. There are some programs, however, that are made to run on 5.25" disk and no other. Usually these are programs that directly access the slot 6 ROM to improve disk access time.

Various Thoughts: GBBS would be, in my opinion, the best BBS software to get for the Computist BBS. There are thousands of BBSs running off of it and there is tremendous support for it.

I just bought a little graphics package called Spectragraphix 256. It kind of resembles Iconix in what it does. It allows you to use Applesoft BASIC to draw on the super hi-res screen, animate shapes, and put text anywhere on the super hi-res screen. The program itself is really good, but the documentation leaves a lot to be desired. A revised manual with lots more commented examples would make this a first rate package.

TML Systems will be releasing TML Pascal II around the first of July 89. That is when Apple will be releasing the GS System Disk v5.0. One intriguing feature of the new language system is the inclusion of a Resource Editor. No longer will GS programmers have to deal with cryptic menu strings and the like. The resource editor will allow the programmer to design on screen what the menus, windows, and general operating environment will look like by a simple point-and-click method: WYSIWYG programming! The upgrade for registered TML Pascal and TML BASIC owners is \$49.95, and the new Source Code Library II is available for \$29.95. GS programmers should look into this new package.

Softkey for...

#### Monsters and Make Believe

Pelican Software

This softkey is the same as the softkey for PIRATES GS in Computist #61, page 8.

#### Putting a deprotected Ultima I on a single disk side

I recently purchased the re-released version of Ultima I. The original was written in BASIC and after playing it for a while you really noticed the lack of speed. The re-release, however, has been completely rewritten in assembly language. No more annoying waits; everything moves crisply and quickly. I deprotected the disk so I could play with a backup. Another benefit I wanted was to put the program on a 3.5" disk, since it was ProDOS based, and to run it after Diversi-Cache had been installed so it would load super quick. Copying the files over to the 3.5" disk was no problem. Running it was no problem. The only problem came when I wanted to save a game. It would not save to the same disk; it had to save its games onto another disk. Now that turned out to be really annoying. Why couldn't I save the games on the same disk that contained the program files? Not enough space? Wrong. The saved game file is only a block or two long; it could fit with no trouble on the 5.25" disk the original copy was on. It turned out that the problem was pathnames.

The program disk for Ultima I is named /U1 and the data disk is named /U1.PLAYER. Since the program and data disk names were not the same, I couldn't just use one disk to play the game unless I modified the code. Well, I modified the code! Looking through the program files, I came across the program and data disk names in ASCII format. The change I made was to change the data disk's pathname from /U1.PLAYER to /U1/PLAYER. I just changed the period between /U1 and PLAYER to a slash. The result of this is when you go to save a game now, the game is saved to the subdirectory PLAYER, which is located on the program disk. No more disk swapping and super fast loading on a GS with a 3.5" drive and Diversi-Cache. This is how gaming is supposed to go!

1. Deprotect your original Ultima I disk.
2. If you have a 3.5" drive, format a 3.5" disk and name it /A. Now copy all of the files from the deprotected copy to the 3.5" disk. After all of the files have been copied, rename the 3.5" disk to /U1.
3. Boot up ProDOS, get into BASIC, and create a subdirectory on the disk and call it PLAYER:

#### PREFIX /U1 CREATE PLAYER

4. Load up the file with the pathnames in it:

#### UNLOCK MI.U1 BLOAD MI.U1,A\$7000

5. Go into the monitor and change the period in the data disk pathname to a slash:

#### CALL -151 7E3B:2F

was 2E

6. Save the modified file back to disk:

#### BSAVE MI.U1,A\$7000 LOCK MI.U1

You're done! If the pathnames have been moved around in the file, scan the file for the byte sequence 55 31 2E 50 4C (hex values for U1.PL) and change the 2E to a 2F.



# The Hardware Corner

Well here we are again, Hardware City. In part 1, I gave the combined schematic and an explanation of how it works. I also asked for comments on how well the explanation was written. Your response was underwhelming. We didn't even have enough interest to enable us to order the circuit boards. Only a few wrote and your comments were about evenly split between; the explanation was too indepth, the explanation was too shallow or who cares; print more softkeys. A thoroughly discouraging response and I hope it changes soon or I'm going to resign as your hardware guru and let someone else take over. I not only haven't made a goal but it seems that I'm not even on the playing field yet.

So here's part 2 for the handful of readers who are interested (thank goodness for you).

## The Display Card (Part 2)

Here are the actual schematics, parts lists and board layouts for the Display card.

I've tried to give part numbers from the current Jameco catalog whenever possible. I've always bought my parts from Jameco because of their fast service, wide selection of parts and low prices. They do have a minimum order amount, however, so you might have to look elsewhere if you only need a few items.

Circuit card 1 plugs into a slot, while card 2 sits outside. A 14 pin DIP jumper connects the two cards. Figure 1 is the circuit board parts layout diagram for card 2. Figure 3 is its schematic diagram. Figure 2 is the circuit board parts layout diagram for card 1. Figure 4 is its schematic diagram.

This is a fairly simple project and none of the parts are critical. Feel free to substitute whenever necessary. If you have any problems, write to me in care of Computist. If anyone knows of a place where we can get the boards made at a reasonable cost please let me know.

### Card 1 Parts List

| Label | item                    | Jameco # |
|-------|-------------------------|----------|
| C1    | 4.7 $\mu$ f capacitor   | R4.7/50  |
| C1    | .1 $\mu$ f capacitor    | DC.1     |
| C2    | .1 $\mu$ f capacitor    | DC.1     |
| IC1   | 74LS521                 | 74HCT688 |
| IC2   | 74LS374                 | 74HCT374 |
| IC4   | 74LS02                  | 74HCT02  |
| IC5   | 74LS08                  | 74HCT08  |
| IC6   | 74LS74                  | 74HCT74  |
| IC7   | 555 timer               | NE555V   |
| IC8   | 555 timer               | NE555V   |
| R1    | 2.2 M 1/4 watt resistor | R2.2M    |
| R2    | 220 K 1/4 watt resistor | R220K    |
| R3    | 10 K 1/4 watt resistor  | R10K     |
| R4    | 10 K 1/4 watt resistor  | R10K     |
| R5    | 10 K 1/4 watt resistor  | R10K     |
| R6    | 10 K 1/4 watt resistor  | R10K     |

### Misc.

|       |                                |           |
|-------|--------------------------------|-----------|
| 2 ea. | 8 pin DIP socket               | 8LP       |
| 4 ea. | 14 pin DIP socket              | 14LP      |
| 2 ea. | 20 pin DIP socket              | 20LP      |
| 1 ea. | 14 pin DIP to DIP jumper (24") | DJ16-2-16 |

### Notes

P1 is a 14 pin DIP socket. The DIP jumper part number listed is for a DIP jumper with 16 pins, be careful that you connect it correctly to both boards. (Or you could find another source for a 14 pin DIP to DIP jumper.) Capacitor C1 is a filter capacitor that fits on the lower right corner of circuit board 1.

### Card 2 Parts List

| Label | item                      | Jameco #  |
|-------|---------------------------|-----------|
| C1    | .01 $\mu$ f capacitor     | DC.01     |
| C2    | 4.7 $\mu$ f capacitor     | R4.7/50   |
| D1    | 1N914 small signal diode  | 1N4148    |
| IC2   | 74LS138                   | 74LS138   |
| IC3   | 74LS138                   | 74LS138   |
| IC4   | 74LS138                   | 74LS138   |
| IC5   | 555 timer                 | NE555V    |
| IC6   | 74LS21                    | 74LS21    |
| LA1   | 16 individual LEDs        | XC57124R  |
| LA2   | 5 individual LEDs         | XC57124R  |
| R1    | 1 K 1/4 watt Resistor     | R1.0K     |
| R2    | 500K Horiz mount trim Pot | 3355-500K |
| R3    | 1/4 watt resistor         | R470      |
| R4    | 1/4 watt resistor         | R470      |
| SWT1  | SPST switch (PC mount)    | SW135     |
| SWT2  | push button switch        | SW178     |
| SWT3  | SPDT switch (PC mount)    | SW135     |
| SWT4  | SPST switch (PC mount)    | SW135     |

### Misc.

|       |                   |      |
|-------|-------------------|------|
| 1 ea. | 8 pin DIP socket  | 8LP  |
| 2 ea. | 14 pin DIP socket | 14LP |
| 3 ea. | 16 pin DIP socket | 16LP |

### Notes

P1 is a 14 pin DIP socket. Use short lengths of wire to solder swt2 to the board, than use a dab of silicon seal to glue the switch to the board. The part numbers shown for the SPST switches are actually for DPDT switches. (They sold out of the SPST switches.) Clip the extra pins and they'll work just fine. If they're out of SW135 try SW127.

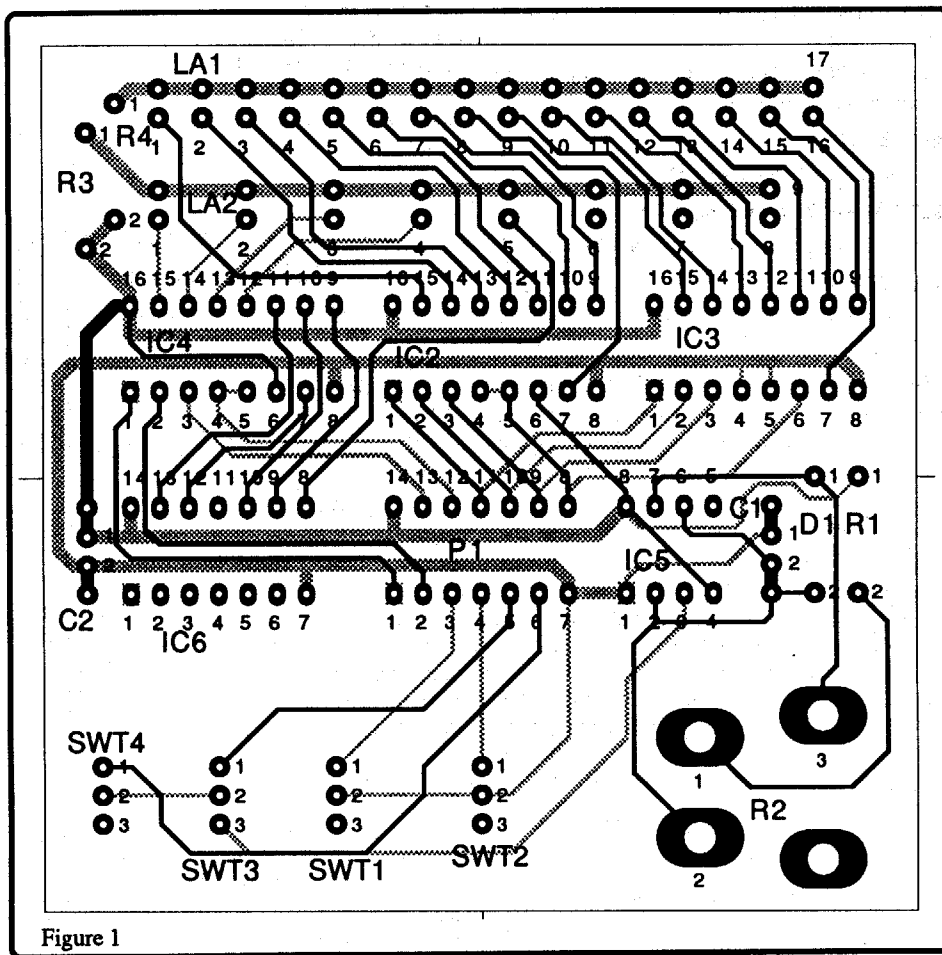

Figure 1

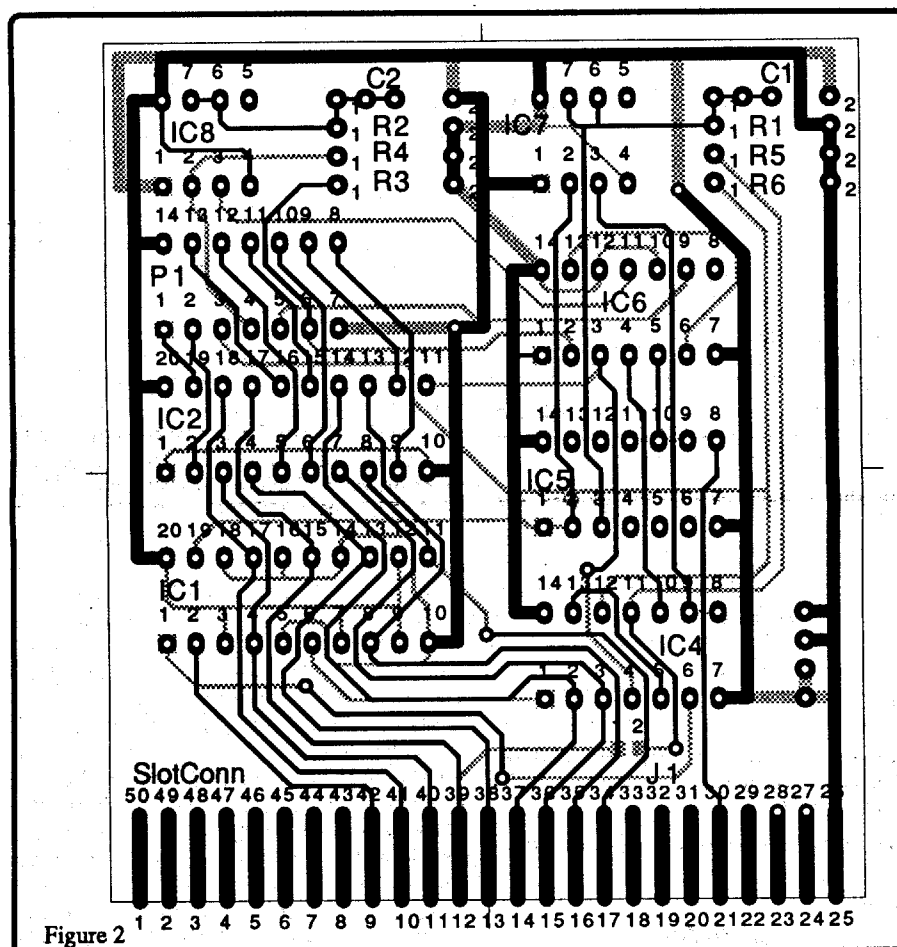

Figure 2

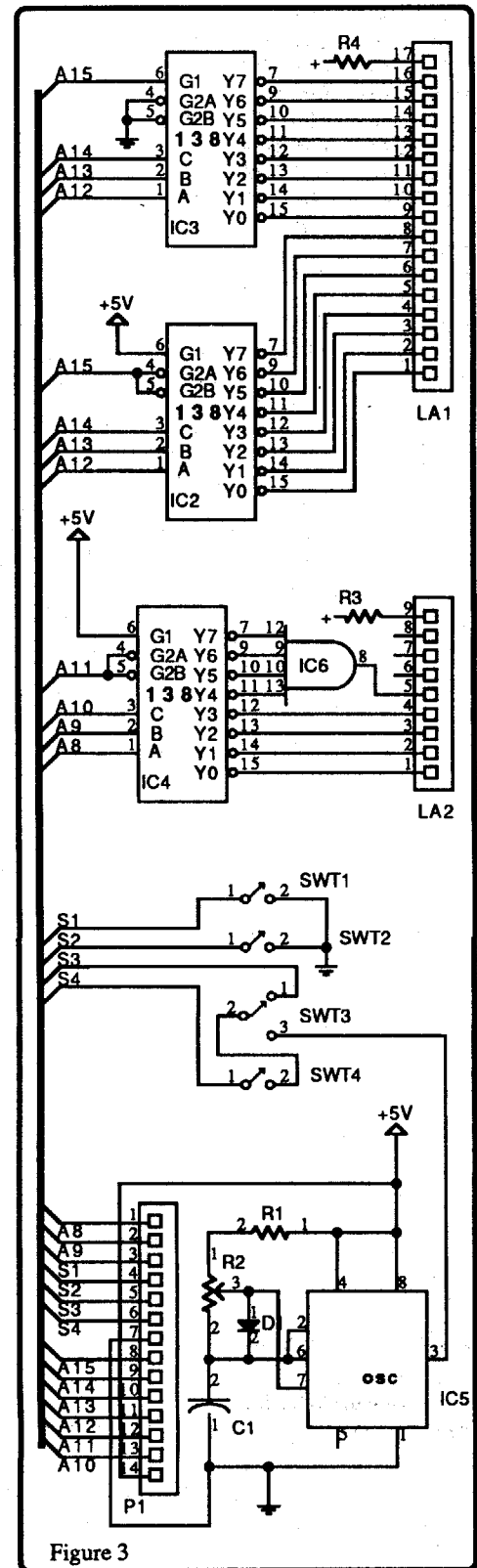

Figure 3

The circuit diagrams and board layouts were drawn using Douglas CAD. The layout files, parts lists and NET lists are available on 3.5" disk (Apple Mac format) for those of you who can make use of the information. Send \$3 to cover the cost of the disk plus postage and handling.

I suppose I could even convert it to a standard text file as postscript code. I'll look into that a little more if it turns out that anyone is interested.

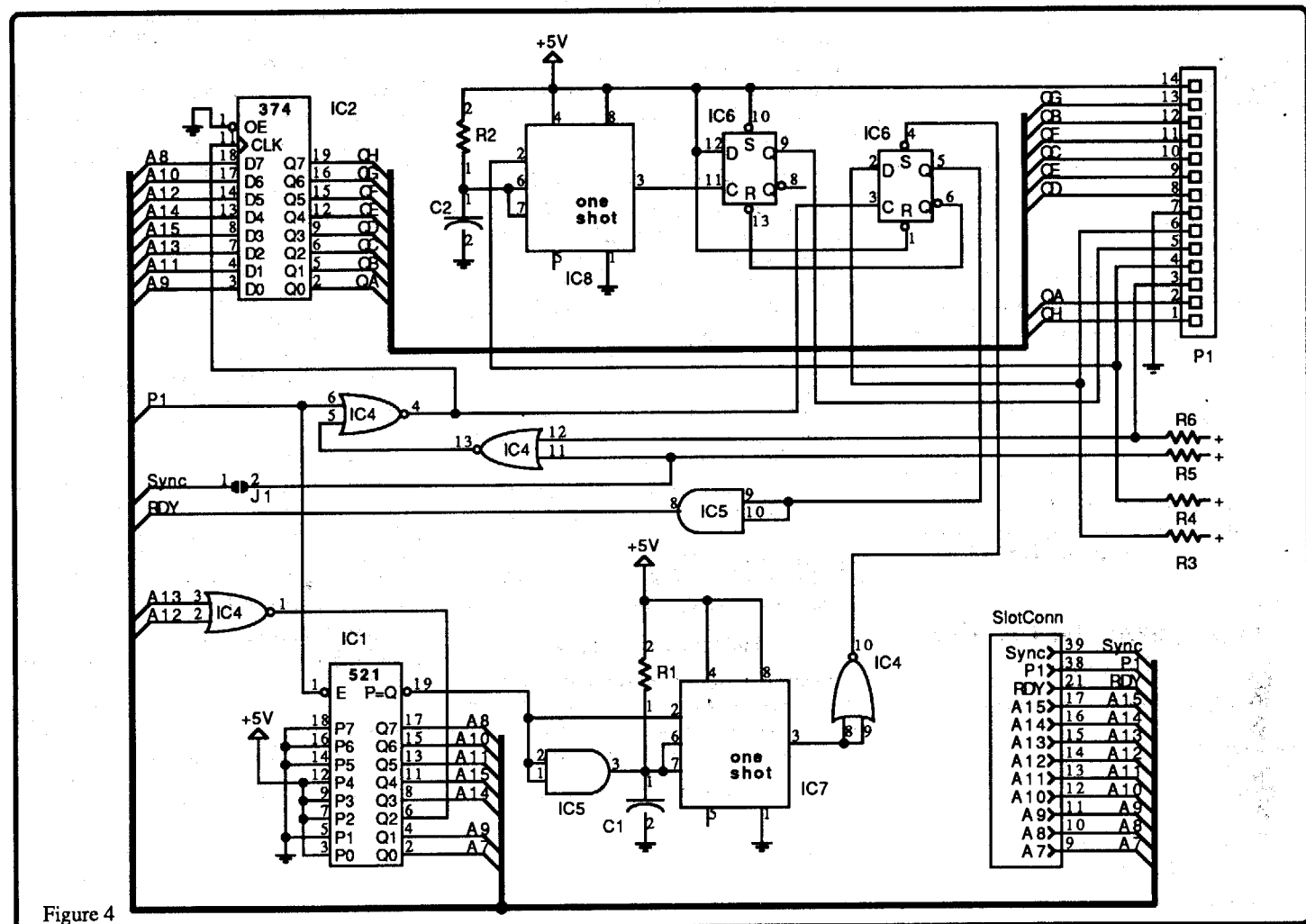

Figure 4

**Marc Batchelor FL**

Softkey for...

**Zany Golf**  
*Electronic Arts*

A friend recently asked me to come up with a crack to Zany Golf. Zany Golf (ZG) is protected with a code. That is, upon reaching the Hamburger Hole, you are faced with the following type of prompt:

ENTER CODE: Windmill 4 Iron Eagle:

You must look in the manual, locate this sequence and type the four character code associated with the above "clue". While this is effective in preventing casual "giving" of the program to friends, it does not do much in the way of protection since many career pirates will diligently type in code tables, code wheels, etc. and distribute the information on the disk as a textfile for printing. The code idea is also a hassle for registered owners and real users. However, I prefer this kind of "protection" to nibble checks and key disks. This is easily installable on a harddrive and is a joy to play.

**The Protection:**

The protection resides in the file ZANY.COM. If you DEBUG the program and search from 100 to FFFF for the "ENTER CODE", you will find that it spits out one address. Searching for references to the byte preceding this address (length byte) will turn up a reference in the \$F500 page (for the benefit of true IBM'ers, '\$' means HEX). I then traced the code all the way to it's conclusion where it either continued or performed a call to \$1CA2, which sets the video mode and exits via INT 20. Looking at how the code branched, I found that \$F754 was where the code branched too, on successful entry of the code. The test for this I found at \$F736. The code looked like the following:

```

XXXX:F736 75 03  JNZ  F73B
XXXX:F738 E9 19 00 JMP  F754
XXXX:F73B                    Crash Code
XXXX:F754                    Start Hamburger Hole
    
```

To circumvent this check, I decided to overwrite some of the code in the \$F500 page (before the ENTER CODE message was displayed).

**S100 FFFF 75 03 E9 19 00 89 C2**

Response S/B: XXXX:YYYY. Write down YYYY and use in next step.  
**YYYYY**

Response S/B:  
XXXX:YYYY 75 03 JNZ ????  
XXXX:YYZZ E9 19 00 JMP AABB

Write down AABB to use later.

**S100 FFFF B8 88 F7 A3**

Response S/B: XXXX:CCCC. Write down CCCC and use in next step.

**ACCCC**

Response S/B: XXXX:CCCC

**JMP AABB**

**NOP**

press return here

**W**

Writing XXXX Bytes.

You should be done. Now, the program will continue to load and execute the hamburger hole without asking you for the code. That's it.

Advanced Playing Technique for...

**Zany Golf**

*Electronic Arts*

For those interested in obtaining unlimited strokes, follow this procedure:

**DEBUG ZANY.COM**  
**S100 FFFF 8A 84 F4 59 3C 01 F5**

XXXX:YYYY  
**YYYYY**

MOV AL, [SI+ZZZZ]      Write down ZZZZ  
CMP 01  
CMC

**AYYYYY**

XXXX:YYYY

**MOV AL,05**

**MOV [SI+ZZZZ],AL**      ZZZZ is obtained from above  
**RET**

This provides unlimited strokes WITHOUT affecting total scoring. Therefore, if you do hit the ball 49 times on the energy hole, it shows up on your score card. Enjoy.

*This information was sent to us on disk. It is from a BBS. The names were removed before we got them so we are unable to give the authors proper credit. If you recognize a procedure, please let us know. We would like to receive the info direct from you next time.*

Playing Tips for ...

**Manhunter**

|                          |                                                                                                                                                               |
|--------------------------|---------------------------------------------------------------------------------------------------------------------------------------------------------------|
| video game               | Find the shortest path; record t three dolls for Coney Island.                                                                                                |
| The sewer maze           | The sewer maze is the same as the video game.                                                                                                                 |
| Seasons combinations     | (4,1) (1,0,3,1) (2,6,4) (4,2,5).                                                                                                                              |
| Suspect names            | Phillipe Cook, Harvey Osborne, Anna Osborne, Harry Jones.                                                                                                     |
| MAD information          | The names are: Harvey Osborne, Harry Jos, Phillipe Cook.                                                                                                      |
| The church candles       | Top Row: 1st candle;<br>2d Row: 3rd candle;<br>3rd Row: 4th candle.                                                                                           |
| Theatre safe combination | The safe combination is: 8439.                                                                                                                                |
| The computer password    | The computer password is UCUC.                                                                                                                                |
| The computer action      | Change the robot from special guard to hall patrol.                                                                                                           |
| The museum dragon        | Show the dragon the medallion.                                                                                                                                |
| The target sites         | The Statue of Liberty,<br>The Empire State Building,<br>Bellevue Hotel<br>Grand Central Station.                                                              |
| The space ship buttons   | plug in the four modules,<br>power on (upper left),<br>middle square button,<br>middle screen button,<br>right screen button,<br>right & left square buttons. |

Advanced Playing Technique for ...

**Wizardry V**

*Sir Tech*

Use of a good sector editor (NU from Norton Utilities for example) can allow one to modify selected data to create a playable set of characters for Wizardry 5, rather than the 'wimps' one usually starts with. This gives a player a chance to play with 'decent' characters. Data resides on sectors 92 - 93 -94 (a disk has sectors 0-719 decimal).

|                    |         |         |         |         |         |         |
|--------------------|---------|---------|---------|---------|---------|---------|
| Contents (& Notes) | Char. 1 | Char. 2 | Char. 3 | Char. 4 | Char. 5 | Char. 6 |
| Sector #           | 92      | 92      | 92-93   | 93      | 93-94   | 94      |

(All of the following locations are in Hex)

|                    |       |         |         |        |         |       |
|--------------------|-------|---------|---------|--------|---------|-------|
| # Char in name     | 0     | F6      | 1EC     | 1D8    | CE      |       |
| Char name (15 MAX) | 1-F   | F7-105  | 1ED-1FB | E3-F1  | 1D9-1E7 | CF-DD |
| # Char in password | 10    | 106     | 1FC     | F2     | 1E8     | DE    |
| Password name (15) | 11-1F | 107-115 | 1FD-B   | F3-101 | 1E9-1F7 | DF-ED |
| Race (1 TO 5)      | 20    | 116     | C       | 102    | 1F8     | EF    |
| Class (0 TO 7)     | 22    | 118     | E       | 104    | 1FA     | F0    |
| Alignment (1 TO 3) | 24    | 11A     | 10      | 106    | 1FC     | F2    |

lockbit (boolean), status, age (Integer), ability, saving throw (go here)

|                             |       |         |       |         |       |         |
|-----------------------------|-------|---------|-------|---------|-------|---------|
| # Gold (LO-HI BYTES)        | 34-35 | 12A-12B | 20-21 | 116-117 | C-D   | 102-103 |
| Items held (8)              | 3A    | 130     | 26    | 11C     | 12    | 108     |
| Actual items (8 bytes each) | 3C-5B | 132-151 | 28-47 | 11E-3D  | 14-33 | 10A-129 |
| ## Experience (Lo-Hi)       | 5C-5F | 152-155 | 48-4B | 13E-141 | 34-37 | 12A-12D |
| Previous level              | 62    | 158     | 4E    | 144     | 3A    | 130     |
| Current level               | 64    | 15A     | 50    | 146     | 3C    | 132     |
| ### Current hit points      | 66-67 | 15C-15D | 52-53 | 148-149 | 3E-3F | 134-135 |
| ### Maximum hit Points      | 68-69 | 15E-15F | 54-55 | 14A-14B | 40-41 | 136-137 |

Spells known, m spell available, c spell available, fight level, armrclass, regen, poison, autokill, numswings, damage (go here)

Race: 1 = Human, 2 = Elf, 3 = Dwarf, 4 = Gnome, 5 = Hobbit  
Class: 0 = Fighter, 1 = Mage, 2 = Priest, 3 = Thief, 4 = Bishop, 5 = Samuri, 6 = Lord, 7 = Ninja  
Alignment: 1 = Good, 2 = Neutral, 3 = Evil

|                      |       |         |
|----------------------|-------|---------|
| Good ones to change: | Hex   | Decimal |
| # Gold               | 5555  | 21845   |
| # Experience         | 55555 | Lots    |
| # Hit points         | C7    | 199     |

Be careful, putting in too large a number makes the value negative.

**Rocket Ranger codes**

| Country     | Alge | Arab | Atla | Braz | Cana | Colu | Cong | E.Af | Egypt | Engr | Fran | Germ | Ital | Keny | Liby | Mide | Nige | Pers | Peru | Scan | Spai | Suda | USA  | USSR | Vene | W.Af | Yugo |    |
|-------------|------|------|------|------|------|------|------|------|-------|------|------|------|------|------|------|------|------|------|------|------|------|------|------|------|------|------|------|----|
| Algeria     | 0    | 28   | 20   | 43   | 37   | 44   | 25   | 29   | 21    | 16   | 14   | 17   | 15   | 31   | 10   | 19   | 23   | 30   | 50   | 22   | 13   | 24   | 36   | 26   | 40   | 18   | 12   |    |
| Arabia      | 28   | 0    | 41   | 57   | 59   | 65   | 30   | 18   | 14    | 34   | 29   | 27   | 24   | 26   | 20   | 17   | 31   | 12   | 70   | 32   | 33   | 19   | 8    | 3    | 61   | 37   | 22   |    |
| Atlantic    | 20   | 41   | 0    | 32   | 27   | 34   | 37   | 39   | 33    | 18   | 19   | 26   | 22   | 43   | 29   | 31   | 35   | 42   | 44   | 25   | 17   | 36   | 23   | 38   | 30   | 24   | 28   |    |
| Brazil      | 43   | 57   | 32   | 0    | 49   | 27   | 38   | 48   | 52    | 50   | 45   | 53   | 47   | 46   | 42   | 54   | 3    | 61   | 25   | 55   | 40   | 44   | 41   | 60   | 28   | 33   | 51   |    |
| Canada      | 37   | 59   | 27   | 49   | 0    | 28   | 56   | 62   | 51    | 31   | 36   | 3    | 39   | 64   | 44   | 47   | 48   | 55   | 40   | 34   | 35   | 57   | 10   | 41   | 26   | 42   | 43   |    |
| Columbia    | 44   | 65   | 34   | 27   | 28   | 0    | 52   | 59   | 46    | 50   | 48   | 62   | 49   | 57   | 45   | 66   | 17   | 51   | 43   | 61   | 26   | 58   | 12   | 39   | 53   |      |      |    |
| Congo       | 25   | 30   | 37   | 38   | 56   | 52   | 0    | 22   | 23    | 36   | 33   | 34   | 32   | 17   | 24   | 26   | 15   | 31   | 54   | 40   | 29   | 20   | 55   | 39   | 50   | 21   | 27   |    |
| E.Africa    | 9    | 18   | 39   | 48   | 62   | 64   | 22   | 0    | 15    | 37   | 32   | 33   | 30   | 14   | 23   | 24   | 25   | 19   | 67   | 35   | 31   | 12   | 61   | 28   | 60   | 34   | 26   |    |
| Egypt       | 21   | 14   | 33   | 52   | 51   | 59   | 23   | 15   | 0     | 27   | 24   | 20   | 19   | 25   | 12   | 11   | 18   | 17   | 63   | 28   | 26   | 13   | 0    | 22   | 54   | 29   | 16   |    |
| England     | 16   | 34   | 18   | 50   | 31   | 47   | 36   | 37   | 27    | 0    | 8    | 11   | 13   | 40   | 21   | 22   | 33   | 29   | 53   | 15   | 12   | 3    | 32   | 19   | 41   | 28   | 20   |    |
| France      | 14   | 29   | 19   | 45   | 36   | 46   | 33   | 32   | 24    | 8    | 0    | 12   | 10   | 37   | 1    | 20   | 30   | 28   | 52   | 16   | 9    | 27   | 35   | 21   | 42   | 25   | 15   |    |
| Germany     | 17   | 27   | 26   | 53   | 38   | 50   | 34   | 33   | 20    | 11   | 12   | 0    | 9    | 35   | 1    | 14   | 32   | 24   | 58   | 10   | 16   | 29   | 39   | 15   | 45   | 31   | 13   |    |
| Italy       | 15   | 24   | 22   | 47   | 39   | 48   | 32   | 3    | 19    | 13   | 10   | 9    | 0    | 33   | 14   | 12   | 29   | 25   | 57   | 17   | 11   | 26   | 38   | 18   | 44   | 27   | 8    |    |
| Kenya       | 31   | 26   | 43   | 46   | 64   | 62   | 17   | 14   | 25    | 40   | 37   | 35   | 33   | 0    | 28   | 30   | 22   | 27   | 65   | 39   | 36   | 18   | 63   | 34   | 59   | 32   | 29   |    |
| Libya       | 0    | 20   | 29   | 42   | 4    | 49   | 24   | 23   | 12    | 21   | 17   | 18   | 14   | 28   | 0    | 13   | 19   | 22   | 56   | 27   | 15   | 16   | 43   | 25   | 46   | 26   | 11   |    |
| Midecast    | 9    | 17   | 31   | 54   | 47   | 57   | 26   | 24   | 11    | 22   | 20   | 14   | 12   | 30   | 13   | 0    | 28   | 18   | 64   | 21   | 25   | 23   | 46   | 16   | 52   | 36   | 10   |    |
| Nigeria     | 23   | 31   | 35   | 37   | 48   | 45   | 15   | 25   | 18    | 33   | 30   | 32   | 29   | 22   | 19   | 28   | 0    | 34   | 9    | 36   | 27   | 17   | 47   | 40   | 43   | 16   | 24   |    |
| Persia      | 30   | 12   | 42   | 61   | 55   | 66   | 31   | 19   | 17    | 29   | 28   | 24   | 25   | 27   | 22   | 18   | 34   | 0    | 72   | 2    | 32   | 21   | 54   | 20   | 62   | 41   | 23   |    |
| Peru        | 50   | 70   | 44   | 25   | 40   | 17   | 54   | 67   | 63    | 53   | 52   | 58   | 57   | 65   | 56   | 64   | 49   | 72   | 0    | 60   | 51   | 62   | 33   | 66   | 20   | 43   | 61   |    |
| Scandinavia | 22   | 32   | 25   | 55   | 34   | 51   | 40   | 3    | 28    | 15   | 16   | 10   | 17   | 39   | 27   | 21   | 36   | 26   | 60   | 0    | 20   | 31   | 37   | 14   | 47   | 38   | 18   |    |
| Spain       | 13   | 33   | 17   | 35   | 43   | 29   | 31   | 26   | 12    | 9    | 16   | 11   | 36   | 15   | 25   | 27   | 32   | 51   | 20   | 0    | 28   | 34   | 24   | 39   | 23   | 19   |      |    |
| Sudan       | 24   | 19   | 36   | 44   | 57   | 61   | 20   | 12   | 13    | 30   | 27   | 29   | 26   | 18   | 16   | 23   | 17   | 21   | 62   | 31   | 28   | 0    | 56   | 32   | 55   | 22   | 25   |    |
| USA         | 36   | 58   | 23   | 41   | 10   | 26   | 55   | 61   | 50    | 32   | 35   | 39   | 38   | 63   | 43   | 46   | 47   | 54   | 33   | 37   | 34   | 56   | 0    | 45   | 24   | 40   | 42   |    |
| USSR        | 26   | 23   | 38   | 60   | 41   | 58   | 39   | 28   | 22    | 19   | 21   | 15   | 18   | 34   | 25   | 16   | 40   | 20   | 6    | 14   | 24   | 32   | 45   | 0    | 53   | 44   | 17   |    |
| Venezuala   | 40   | 61   | 30   | 28   | 26   | 12   | 50   | 60   | 54    | 41   | 42   | 45   | 44   | 59   | 46   | 52   | 43   | 62   | 20   | 47   | 39   | 55   | 24   | 53   | 0    | 35   | 49   |    |
| W.Africa    | 18   | 37   | 24   | 33   | 42   | 39   | 21   | 34   | 29    | 28   | 2    | 31   | 27   | 32   | 26   | 36   | 16   | 43   | 38   | 23   | 22   | 40   | 44   | 35   | 0    | 30   |      |    |
| Yugoslavia  | 12   | 22   | 28   | 51   | 43   | 53   | 27   | 26   | 16    | 20   | 15   | 13   | 8    | 29   | 11   | 10   | 24   | 23   | 61   | 18   | 19   | 25   | 42   | 17   | 49   | 30   | 0    |    |
| Checksums:  |      |      |      |      |      |      |      |      |       |      |      |      |      |      |      |      |      |      |      |      |      |      |      |      |      |      |      |    |
| Sum Vert    | 663  | 87   | 793  | 1158 | 1099 | 1203 | 866  | 888  | 7     | 723  | 682  | 709  | 667  | 955  | 670  | 736  | 803  | 891  | 1352 | 794  | 688  | 804  | 1068 | 838  | 1117 | 814  | 692  |    |
| Sum Horiz   | 663  | 887  | 793  | 1158 | 1099 | 203  | 866  | 888  | 742   | 723  | 682  | 709  | 667  | 955  | 670  | 736  | 803  | 891  | 1352 | 794  | 688  | 804  | 1068 | 38   | 1117 | 814  | 692  |    |
| OK          | O    | OK   | OK   | OK   | OK   | OK   | OK   | OK   | OK    | OK   | OK   | OK   | OK   | OK   | OK   | OK   | OK   | OK   | OK   | O    | OK   | OK   | OK   | OK   | OK   | OK   | OK   | OK |

Objective: Find the 5 secretly located rocket labs, obtain the components to build a rocket ship, capture enough lunarium to fly to the source of the Nazis' power, the Moon. Rescue Otto and Jane Barnstorff: (3 chances) 1 Zeppelin - destroy aerial torpedoes & board zeppelin. 2 Germany - reach bomb factory (destroy ME-19's first) & rescue them. 3 Desert Base - blast ack-ack batteries & rescue them.

# unClassifieds

## How to place an UnClassified Ad

If possible, send text on a 5 1/4 inch Apple formatted disk, include a typed sample copy with appropriate instructions. Use up to 40 characters per line, we will adjust word wrap. The Computist club member charge is \$4 (for processing) plus 50 cents per line. For non-members, the charge is \$4 plus \$1 per line. Multiple insertions of the same ad are charged only for the line rate, unless changes are made to the copy.

**Special Graphics Instructions:** The first three words of the first line are printed in bold for free. If you want other words bolded, use 5 characters less per line. Use 10 characters less per line if you have a lot of uppercase bold letters. Bold letters are wider than normal. Circle the words you want bolded. If you want a line centered, write CENTER next to that line. There is no charge for centering any line.

You must check your ad for errors, the first time it runs. Errors on our part will be corrected, then, for free. Errors or changes on your part will be charged the \$4 processing fee.

Our liability for errors or omissions is limited to the cost of the ad.

We reserve the right to refuse any ad.

Washington state residents add 7.8% sales tax.

Send a check or money order (funds drawn on US bank only) for the entire amount to:

COMPUTIST unCLASSIFIEDS  
33821 East Orville Road  
Eatonville, WA 98328

## RENT IIgs SOFTWARE

- \* Rent 99% of Commercial Software
- \* 60 Day Money Back Guarantee
- \* As Low as 10% of List Price
- \* Pay By Week, the Choice is Yours
- \* \$15 Lifetime Membership Fee
- \* START SAVING NOW !!!!

GSoft

2201 Whittington Way #1503C  
Tampa, Florida 33612

## Get more out of your computer!

Subscribe to the newsletter for the machine you own. Only \$5 for a one year subscription (12 issues). We publish:

- Adam Newsletter
- Apple II+ Newsletter
- Atari 800 Newsletter
- Atari 1040ST Newsletter
- Commodore 64 Newsletter
- IBM PC/XT Newsletter
- IBM PC/AT Newsletter
- Morrow Newsletter
- TRS-80 Newsletter
- VIC-20 Newsletter

As an introductory offer, you may submit one advertisement of up to 50 words (text only - no illustrations) for free publication in our next issue of each newsletter you subscribe to.

Send \$5 for each publication checked to:

National Computer Information Service  
1324 Ava Road  
Severn, Maryland 21144

You will receive your first issue(s) in about two weeks.

## RDEX Contributors:

|                         |            |
|-------------------------|------------|
| Vincent Andrews .....   | 10         |
| Marc Batchelor .....    | 13, 21, 22 |
| B. Dudley Brett .....   | 16         |
| Stephen M. Caraco ..... | 12         |
| David Goforth .....     | 5, 11      |
| Ravi Hariprasad .....   | 16         |
| Jim S. Hart .....       | 19         |
| John Ianzano .....      | 13         |
| Bob Igo .....           | 14         |
| Paul A. Johnson .....   | 15         |
| Keith .....             | 12         |
| Mopman .....            | 15         |
| The Dark Phoenix .....  | 12         |
| Ron Powers .....        | 12         |
| Carl D. Purdy .....     | 12         |
| George Sabeh .....      | 6          |
| Charles Taylor .....    | 5          |
| Brian A. Troha .....    | 6          |
| Captain Video .....     | 6          |
| Jeffrey A. Wisnia ..... | 14         |

|                                 |                              |
|---------------------------------|------------------------------|
| Operation Wolf                  | Taito                        |
| Pensate                         | Datasoft/Softdisk            |
| Phantoms 5                      | Sirius                       |
| Pig Pen                         | Datamost                     |
| Platoon                         | Data East                    |
| Project: Space Station          | Avantage                     |
| Pulsar II                       | Sirius                       |
| Pure Stat Basketball            | ?                            |
| Quadratic Equations II          | Olympus Educational Software |
| Questron II                     | Electronic Arts              |
| Rails West                      | SSI                          |
| Rastan                          | Taito                        |
| Read n' Roll                    | Davidson                     |
| Rear Guard                      | Adventure International      |
| Renegade                        | Taito                        |
| Rescue Raiders                  | Sir Tech                     |
| Rings of Saturn                 | Level 10                     |
| Risk                            | Leisure Games                |
| Rocket Ranger (Iigs)            | Cinemaware                   |
| S.D.I. (Iigs)                   | Cinemaware                   |
| Sailing Trough Story Problems   | DLM/Neosoft                  |
| Sea Stalker                     | Broderbund                   |
| Serpentine                      | Broderbund                   |
| Skeletal System                 | Brainbank                    |
| Sky Shark                       | Taito                        |
| Sound Song & Vision             | Advanced Software            |
| Space Ark                       | Datamost                     |
| Spare Change                    | Broderbund                   |
| Spectre                         | Datamost                     |
| Speedy Spides                   | Readers Digest               |
| Star Cruiser                    | Sirius                       |
| Star Maze                       | Sir Tech                     |
| StickyBear Math: Add & Subtract | Optimum Resources            |
| Stickybear GS Versions 3.5      | Xerox                        |
| Strike Fleet                    | Electronic Arts              |
| Succession                      | Piccadilly                   |
| Superstar Ice Hockey            | Mindscape                    |
| Superstar Indoor Sports         | Mindscape                    |
| Talking Text Writer GS          | Scholastic                   |
| Tangled Tales                   | Origin Systems               |
| Test Drive                      | Accolade                     |
| Tetris (Ile)                    | Spectrum Holobyte            |
| The Three Stooges (Iigs)        | Cinemaware                   |
| Thunder Chopper                 | ?                            |
| Ticket to Washington D.C.       | Blue Lion Software           |
| Tomahawk                        | Electronic Arts              |
| Tomahawk (Iigs)                 | Datasoft                     |
| Triad                           | AI/Thunder Mountain          |
| Trinity                         | Infocom                      |
| Ultima Trilogy                  | Origin Systems               |
| Volcanoes v1.8                  | Earthware Comp. Services     |
| War in the Middle Earth         | Melbourne                    |
| Wasteland                       | Electronic Arts              |
| Wayout                          | Sirius                       |
| Wings of Fury                   | Broderbund                   |
| Wizardry:Return of Werda        | Sir-Tech.                    |
| Word Attack Plus (Iigs)         | Davidson                     |
| Works (the)                     | First Star Software          |
| Zenith                          | Softsmith                    |
| ZorkQuest                       | Infocom                      |

## Most Wanted

|                                        |                                |
|----------------------------------------|--------------------------------|
| Airheart                               | Broderbund                     |
| Alcon                                  | Taito                          |
| Alien Mind                             | PBI Software                   |
| Apple Panic                            | Broderbund                     |
| Aquatron                               | Sierra                         |
| Arkanoid                               | Taito                          |
| Arkanoid II                            | Taito                          |
| Bad Street Brawler                     | Mindscape                      |
| Bank Street Writer Plus                | Broderbund                     |
| Beyond Zork                            | Infocom                        |
| Bilestoad                              | Datamost                       |
| Border Zone                            | Infocom                        |
| Borg                                   | Sirius                         |
| Bouncing Kamungas                      | Penguin                        |
| Boxing                                 | ?                              |
| Bubble Ghost Iigs                      | Accolade                       |
| Bureaucracy                            | Infocom                        |
| Centauri Alliance                      | Broderbund                     |
| Chuck Yeager's Advanced Flight Trainer | Electronic Arts                |
| C'est La Vie                           | Adventure International        |
| Comics                                 | Accolade                       |
| Cosmic Relief                          | Datasoft                       |
| Crime & Punishment                     | Imagic                         |
| Crossword Magic v4.0                   | ?                              |
| Darklord                               | Datasoft                       |
| Deathlord                              | Electronic Arts                |
| Desecration                            | Mind Games                     |
| Designasaurus 128K                     | Britanica                      |
| Dig Dug                                | Thunder Mountain               |
| Disk Optimizer System                  | Nibble Notch                   |
| Dondra                                 | Spectrum Holobyte              |
| D&D Master Assitant vol2               | SSI                            |
| Dungeon Master (Iigs)                  | FTL                            |
| DROL                                   | Broderbund                     |
| Eliminator                             | Adventure International        |
| Epoch                                  | Sirius                         |
| Explore-Australia                      | Dataflow Computer Service      |
| Evolution                              | Sydney                         |
| Falcons                                | Piccadilly                     |
| Factastics Trivia                      | Daystar                        |
| Final Assault GS                       | Epyx                           |
| Force 7                                | Datasoft                       |
| Frogger                                | Main Street                    |
| GEOS                                   | Berkley Softworks              |
| Geometry GS                            | Broderbund                     |
| Gladiator                              | Taito                          |
| Goldrush                               | Sierra On Line                 |
| Gorgon                                 | Sirius                         |
| GradeBuster 1 2 3                      | Grade Buster                   |
| Gutenberg Sr.                          | Micromation LTD.               |
| Halls of Montezuma                     | Electronic Arts                |
| High Orbit                             | Softsmith                      |
| Horizon V                              | Softsmith                      |
| Ice Demons                             | Morningstar                    |
| Impossible Mission GS                  | Epyx                           |
| Indoor Sports                          | Mindscape                      |
| Infocomics                             | Infocom                        |
| Jane                                   | ?                              |
| Joker Poker                            | Mindscape                      |
| Kingdom of Facts                       | Santa Barbara/Thunder Mountain |
| King of Chicago                        | Cinemaware                     |
| Lancaster                              | SVS                            |
| Legacy of the Ancients                 | ?                              |
| Lost Tomb                              | Datasoft                       |
| Manhunter New York Iigs                | Sierra On Line                 |
| Math Blaster Plus 3.5                  | Davidson                       |
| Mavis Beacon Teaches Typing (gs)       | Software Toolworks             |
| Microwave                              | Cavalier                       |
| Might and Magic II                     | Activision                     |
| Modem MGR                              | MGR Software                   |
| Mr. Pixel's Cartoon Kit                | Mindscape/Thunder Mountain     |
| Mr. Pixel's Programming Paint Kit      | Mindscape/Thunder Mountain     |
| National Inspirer                      | Tom Snyder Productions         |
| Observatory (The)                      | Mindscape/Lightspeed Software  |
| Odin                                   | Odessta                        |

## IBM Most Wanted

|                    |                              |
|--------------------|------------------------------|
| Graphitti          | George Best Phillips Academy |
| Gunship            | Microprose                   |
| Heros of the Lance | SSI                          |



70 ● Features: Add Eleven Sectors to Your DOS Disks • Apple POKEs, PEEKs and CALLs • Appleworks Printer Control Codes • Converting SSI's Non-RDOS Disks • Copy A Notes • Creating a Super Human Character (Pool of Radianca) • Modifying the HPlot code for Hi-res Hackers • More Power for Your Might and Magic Characters • Print Your Own Graph Paper • Unlimited Thexder Energy • Unlocking Lode Runner's Game Boards • Unlocking the Prolog Protection Scheme • The Product Monitor • Softkeys: 4th & Inches • 4th & Inches Team Construction Disk • 816 Paint v3.1 • Alphabet Circus • Arkanoid • Bank Street Writer Plus • BroadSides v2.0 • Bumble Games • Computer Preparation for the ACT • Dungeon Master • Graphics Bank • How to Weigh an Elephant • Impossible Mission II • Impossible Mission • Into the Eagle's Nest • King of Chicago • LA Crackdown • LA Crackdown • MasterType's Writer • Math Word Problems • MicroZone 14 • Monsters & Make Believe • Monsters & Make Believe Plus • Moptown Parade • Ogre • Pirates II • Ski Crazy • Sokoban • Standing Room Only? • StickyBears Number (ProDOS 1.4) • StickyBears Opposites (ProDOS 1.5) • StickyBears Shapes (ProDOS 1.4) • Summer Games GS • Super Print • Taipan • Techno Cop • The Children's Writing & Publishing Center • Tic-Tac Show • World Games • Writing and Publishing Center • APTs: • Dragon Wars • Elite • Might and Magic II • Pharaoh's Revenge • Pool of Radianca • The Magic Candle vol 1 • Wizardry V: Heart of the Maelstrom • Playing Tips: • Leisure Suit Larry • Might & Magic II • IBM Softkeys • Apollo 18 • Dallas Quest • Defender of the Crown • F-19 Stealth Fighter • Games: Winter Edition (The) • Gold Rush • Infiltrator • Jack's Greatest 18 • Last Ninja (The) • Leisure Suit Larry II • Mean 18 • Perfect College • Police Quest II: The Vengeance

69 ● Features: • Custom Character Sets for the Apple II • A Bug in the Thief Softkey • Deprotecting & Enhancing Applewriter • Imagewriter II Color mapper for Ultima IV • Updating ProDOS 16 Disk to GS/OS • 16 Byte Hex Dump for all II's • The Eamon Adventurer's Guild • Disk Mania: How to really use your 5.25" Drive • Hardware Corner • Build an Activity Monitor and see where your processor is spending it's time • The Product Monitor • Softkeys: • All About America (5.25" disk) • Arkanoid II • California Games GS • Commando • Geopaint • Grizzly Bears • Hitchhiker's Guide to the Galaxy • Kid Niki • Magic Slate II • Might & Magic • Monte Carlo • Notes 'N' Files • Paper Boy GS • Peterson's SAT Success for Micros • Pirates! • Police Quest • Showoff • Silent Service • Space Quest II • Starglider • Street Sports Soccer • The Game Show (1986 version) • The Games: Winter Edition • The Last Ninja GS • The Rings of Zilfin • The Secrets of Science Island • Times of Lore • Ultima I (new release versions) • Warship • Where in the World is Carmen Sandiego (IIGS) • Bitkeys: • Crosscountry USA • Geospell • Geowrite • Bugs • Double DOS • EOADIS Adapter • Ultima V • Notes: • GEOS Notes • ProDOS Directory Format • Pronto Update • ThunderScan Problem • APT's: • Alien Mind • Commando • Thexder (v2.7) • Thief • Playing Tips: • Alien Mind • Bard's Tale III • Leisure Suit Larry • Might & Magic II • Neoromancer • Pirates! • The Turturian • Ultima IV • Wasteland • Zany Golf

68 ● Features, Notes and such: • The Product Monitor • A Mapping Program for Might & Magic I (revisited) • Adding Track Selection to: Locksmith 6.0 Fastcopy • Another Duodisk Modification (Reversible) • BASIC Protection Schemes • Copy Protecting Your Own Disks • Disk Protection on the Apple II (IIGS/IIe) Tips, techniques and tricks • Help to Finish Incomplete Animate Softkey • A General Softkey for Sunburst Software & Mastery Development • Introduction to Disk Usage • Introduction to Shape Tables • Making a Disk for Both Apple and IBM Systems • Nibble Counts/Checks Revisited • Notes on Altered DOS 3.3 Disk • Notes on Computist Super Index • Notes on Newer Electronic Arts • Notes on Softkey for Animate • Playing with ProDOS • Putting Mean 18 (IIGS) on a Hard Drive • Using Print Shop graphics with Beagle Screens • Wizardry V - Bug or Feature? • Softkeys: • Accolade software (IIe) • Accolade software (IIGS) • Activision software (IIe) • Activision software (IIGS) • Addison-Wesley software (IIe) • Alphabet Read Along • AlphaKey • An Apple a Day • The Astronomy Disk • Basic Electricity #8010E • Battlzone • Battling Bugs • Baudville software • Broderbund software (IIe) • Broderbund software (IIGS) • California Games GS • Certificate Library vol 1 • Channelmark software (IIe) • Children's Writing and Publishing Center • Cinemaware Inc. software (IIGS) • Clock Works • Computat Quizware Data Disks • Computat Quizware Startup Disks • Counters • Counting Critters • Counting Read Along • Deja Vu • Digital Codes and Numbering Systems #8700E • Dinosaurs • Dive Bomber • Dr Jessie's Dinosaur • Dungeon Masters Assistant vol 1: Encounters

• Easy Graph • Electronic Arts software (IIe) • Electronic Arts software (IIGS) • Elementary Math • El Mundo Hispanico • Epyx (Lucas Film) software (IIe) • Epyx software (IIGS) • Essential Math Grade 1-8 • Facts Match • Fantasyland • Feet Read Along • First Verbs • Flip Flop • Galactic Attack • Great Book Search • Grolier software (IIGS) • Hartley Courseware software (IIe) • Hobbit • Homonyms, Synonyms & Antonyms Grade 1-8 • Impossible Mission II • Islands of Beta • Isle of Mem • Kindercomp • King of Chicago • Lantern of D'gama • Learning Company software (IIe) • Learning Technologies software (IIe) • Learning to Cope with Pressure • Leisure Suit Larry • Lion's Work Shop • Lucky's Magic Hat • Magic Castle Red Level • Magic Slate (20 Column) • Magic Slate (40 Column) • Magic Slate (80 Column) • Magic Spells • Manager Backup Diskette • Marble Madness • Mastery Arithmetic Games • Math Activities • Math Blaster Plus • Math Facts Games • Math Man • Mathematics Skills Software Series • Micro School Program Series • Microprose software (IIe) • Microprose software (IIGS) • Milliken Mathfun • Milliken Mathfun Golf Classic • Mindplay software (IIe) • Mindscape (Tom Snyder and Alert) software (IIe) • Mindscape software (IIGS) • Number Cruncher • Number Munchers • Number Match • Number Match II • Origin software (IIe) • Otters' Adventure (The) • Parts of Speech I & II • PBI software (IIGS) • Phonics Prime Time: Final Consonants • Phonics Prime Time: Initial Consonants • Pirates • Polarware software (IIe) • Pool of Radianca • Punctuation & Caps • Quick Flash • Rainbow Painter • Rampage • Random House software (IIe) • Reader Rabbit • The Right Job • The Right Resume Writer II • Serve & Volley • Shadowgate • Shanghai (GS) • Show Time • Shutterbug's Patterns • Shutterbug's Pictures • Showoff v1.1 • Sierra On Line software (IIe) • Sierra On Line software (IIGS) • Sir-Tech software (IIe) • Snooper Troops: The Case of the Disappearing Dolphin • Software Toolworks software (IIGS) • Space Quest II • Spectrum Holobyte software (IIe) • Speedway Math • Spelling Grade 1 • Spelling Grade 2 • Spelling Grade 3 • Spelling Grade 4 • Spelling Grade 5 • Spelling Grade 6 • Spelling Grade 7 • Spelling Grade 8 • Spinnaker software (IIe) • Springboard software (IIGS) • Spy's Adventure in North America • Steps to Comprehension • Stickers • Stickybear Math • Stickybear Music • Stickybear Opposites • Story Mix 1 • Story Mix 2 • Story Mix 3 • Story Mix 4 • Story Mix 5 • Story Mix 6 • Strategic Simulations software (IIe) • Styleware (Scholastic) software (IIe) • Success with Typing • Sunburst Communications software (IIe) • Super Print • Survival Math Skills • Talking Stickybear Alphabet (IIGS) • Technocop • Telarium software (IIe) • Telling Time (Analog and Digital) • Type to Learn • Typhoon of Steel • Ultima V • Una Vista a Mexico • Un Dia Tipico • Unicorn software (IIGS) • Uninvited • VCR Companion • Video Title Shop • Voyage of the Mimii: Maps & Navigation • Wally's Word Words: Teacher & Student Elementary • Who Framed Roger Rabbit? • Wizard of Words • Wordfun Snake-o-nyms • Word Flip • Word Picture • Words at Work: Contraction Action • Words at Work: Prefix Power • Working with Decimals • A Wrinkle in Time • Writing Adventure • APTs: • Arkanoid • Gemstone Warrior • Might and Magic II • Ultima V • Wizardry V • Wizardry IV • Xevious • Playing Tips: • Alien Mind • Defender of the Crown • Pool of Radianca • Ultima V • Wizardry IV • IBM Softkeys: • Accolade Software • The Ancient Art of War • Bob 'n' Wrestle • California Games • Chuck Yeager's Advanced Flight Trainer • F-15 Strike Eagle • The Games: Summer Edition • Gato • Winter War II-class Submarine Simulator • Grand Prix Circuit • King's Quest IV: The Perils of Rosella • The Last Ninja • Leisure Suit Larry II • Little Black Book • Manhunter: New York • Mean 18 • Power-up! Software • Rampage • Star Trek: The Kobayashi Alternative • The Three Stooges • Trivia Master • Willow • IBM APTs: • Battletech • Bruce Lee • The Last Ninja • Technocop • BUGS: • Nord and Bert couldn't make Heads or Tails of it • Stellar 7 • Wrath Mapper

67 ● Features: • The Product Monitor • A More Powerful IIe for \$14.95? • Initializing Extra Tracks • Findcat • ProDOS Sector Markers • Making Protected ProDOS Disks • Convert Uncopyable 18 Sector Disks to 16 Sector Disks • An In-Depth Softkey (or how to use the Super IOB Swap Controller without Anxiety) • Convert 8/16 Paints Graphics for Publish It • A Note on Thexder • More Help with Ultima IV • Basic Rules for Cracking Disks • Comments about Copy II Plus • Partial Softkey for Starglider • COPYB • Enhanced COPYA (COPYA+) • Search for all Branches, JMP's, and JSR's • Modify Copy II+ 6.0 for Easier Formatting • Copy Protection for the Beginner • 8-10MHz Speedup Option for the II-IIIe • Softkeys: • AD&D Master Assistant, Vol 1 • Aesop's Fables (IIGS) • Algebra Vols 1, 2, 3 • Alphabet Circus • Ancient Art of War at Sea • Author, Author • Balance of Power • Bard's Tale (IIGS) • Body

Transparent • Calendar Crafter (IIGS) • Castle Wolfenstein • Children's Writing & Publishing Center 1.0 • Cobra Cavern (IIGS) • Comics • D.C. Heath Chemistry Series • Death Sword • DeJa Vu (IIGS) • Deluxe Paint II (IIGS) • Demon's Winter • Designasaurus • Design Your Own Train • Destroyer (IIGS) • Draw Plus v1.0 (IIGS) • Dream Zone (IIGS) • The Dungeon Master's Assistant • Dyno-Quest • Extra! Extra! • The Factory • Fantavision (IIGS) • Fat City • Field of Fire • Fixit • Frog Jump • Gauntlet (IIGS) • Gertrudes Puzzles • Graphics Studio (IIGS) • Graphicwriter (IIGS) • Hacker II (IIGS) • Hardball (IIGS) • Hide and Seek • Indoor Sports • Instant Music (IIGS) • Keyboard Cadet • Keyboard Kadet • King's Quest I (IIGS) • L.A. Crack Down • The Last Ninja • The Last Ninja GS (IIGS) • Leisure Suit Larry (IIGS) • Logic Builders • Magic Spells • Magical Myths (IIGS) • Marble Madness (IIGS) • Math Assistant I: Addition and Subtraction • Math Assistant II: Multiplication and Division • Math Blaster • Mathematics Action Games • Mathematics Today: Silver Series • Mavis Beacon Teaches Typing (IIGS) • Mean 18 (IIGS) • Mini-Converter • Mini-Putt Golf (IIGS) • Multiscribe GS v3.0c (IIGS) • Muppet Word Book (IIGS) • Music Construction Set (IIGS) • Music Studio (IIGS) • NATO Commander 1.1 • Nord and Bert Couldn't Make Heads or Tails of It • Number Bowling • Number Farm • PacMan • Paintworks Plus v1.0 (IIGS) • Paperboy II • Paperboy (IIGS) • Peanut Picture Puzzlers • Perry Mason • Picture Parts • Pipeline • Print Shop (IIGS) • Print Shop (Color) Side 2 • Problem Solving Today: Gold Series • Pyramid Solver • Racter • The Railroad Works • Read & Rhyme (IIGS) • Reader Rabbit (IIGS) • Reading and Me v1.0 (IIGS) • Saracen • Sea Strike (IIGS) • Seesame Street: Crayon Numbers • Shadowgate GS (IIGS) • Shanghai (IIGS) • Shards of Spring • ShowOff (IIGS) • Silent Service (IIGS) • Sinbad's Adventures (IIGS) • Skate or Die (IIGS) • Softswitch (IIGS) • Space Quest v2.2 (IIGS) • Spy's Adventure in North America • Star Maze • Tass Times in Tone Town (IIGS) • Teleport • Thexder (IIGS) • TopDraw (IIGS) • Tower of Myrarglen (IIGS) • Uninvited (IIGS) • Verb Viper • Winter Games (IIGS) • World Games (IIGS) • Writers Choice Elite v1.0 (IIGS) • 4th and Inches (IIGS) • 8/16 Paint (IIGS) • Bitcops: • Ancient Art of War at Sea • Borg • Crusade in Europe • Ice Demons • Jet & Jet Scenery Disk • Kalamazoo Teacher's Record Book • MasterType's Writing Wizard • Rings of Zilfin v1.1 • Where in the USA is Carmen San Diego • Wings of Fury • Softkey Addendums: • MECC ProDOS Software • Movie Monster • MAC Softkey: • Crossword Magic • APT's: • David's Midnight Magic • Into the Eagle's Nest Page • I.O. Silver • Thexder • Wizardry IV: The Return of Werdna • Zany Golf • Playing Tips: • Alien Mind (IIGS) • Bard's Tale III • Castle Wolfenstein • Leisure Suit Larry (IIGS) • Pirates! (IIGS) • Zany Golf (IIGS) • IBM Softkeys: • Lotus 123 v2.01 • Managing Your Money v1.52 • Managing Your Money (all ver) • Print Shop (Color ver) • Sidekick v1.10A • Sidekick v1.11C

66 ● Features: • Displaying Hi-Res and Double Hi-Res pictures from BASIC • The Product Monitor • Treatise on Deprotection: An indepth look at how to go about deprotecting software • Laser 128 - The Dream Machine • Super COPYA 1.1: Automate all those hard to remember patches. • An even BETTER Bootable Thexder under GS/OS. • APT Scanner: A disk search utility to help you make A.P.T.'s. • ProDOS EOR Disk Scanner • New Routines for Super IOB • Softkeys: • 4th & Inches (IIGS) • ACT Preparation • Addition Logician • Adventure Double Feature Vol II • Algebra 1 • Algebra 2 • Algebra Disks 1-6 • Alien Rain • Binomial Multiplication Equations • BroadSides v2.0 • Calendar Crafter (IIGS) • Calendar Crafter v1.1 • California Games (IIGS) • Chessmaster 2100 v1.01 • Computer Drill and Instruction: Mathematics • Addition A+ • Crossword Magic 4.0 • Decimals Disk 1 & 2 • Demon Derby • Discovery Lab • Dive Bomber • Elementary Volume 1 • Equations II • Factoring Algebraic Expressions • Files on the Apple • F.M.C. Program • Fractions • Friendly Computer • Game Show (The) • Geometry Disk 1-5 • Gradebook III • Graphing Linear Functions • Intermediate Algebra • Into the Eagle's Nest • Introductory Algebra • Kid Niki • Radical Ninja • Label Utility • Last Ninja GS (The) • LOGO Robot • Magic Spells • Mastery Arithmetic Games • Math Shop • MECC 1988-89 Copy System • MECC Copy Program • Microzone #25 • Microzone #27 • Microzone #28 • Microzone #29 • Microzone Jr #3 Disk 1 & 2 • Millikens Pre-writing Series: Branching • Brainstorming • Nutshelling • Mindshadow • Mini Putt • Monkey Business • Moptown • Mystery Double Feature Vol 1 • Paint with Words & Word Art Show • Poster • Reading Skills 2 • Right of Way • Sargon III • School Magic • Science Volume 1 • Science Volume 2 • Science Volume 3 • Science Volume 4 • Scrabble • Scruples • Serve & Volley (IIGS) • Simultaneous Linear Equations • Snoggle • Space Subtraction • Spanish for Mastery

Software • Special Needs Volume 2 • Stickybear Alphabet (IIGS) • Subtraction Puzzles • Times of Lore • Word Herd: Look-Alikes • Word Herd: Sound-Alikes • Word Wizards • Zoyon Patrol • APT's • Buck Rogers • Kid Niki • Radical Ninja • Lode Runner • Marble Madness • Montezuma's Revenge • Pirates! • Roadwar 2000 • Saracen • Playing Tips • Maniac Mansion • Marble Madness • Wasteland • Zany Golf • Notes: • Viruses (just say No) • Faulty joystick problems? • Publish It! fonts • Softswitch and the BBR • Fiber Optic LAN • LISP Compiler (Help!) • IIGS Plus rumors • Bugs: • The Bard's Dressing Room III • IBM Softkeys: • Managing Your Money • Print Shop • Reader Rabbit • Xenocopy Plus v1.09

65 ● Features: • The Product Monitor • Appleworks file to text file • Editor Creator II • Making your own APT • Walk-thru guide to Question II • Wrath Mapper • Some IIGS notes • Fixing the Core Disk Searcher • Help with 3 1/2 inch disk protection • Softkeys • Adventure with Fractions • Bard's Tale II (gs) • Certificate Maker's Library vol 1 • Coast To Coast • Create-a-Base • Design Your Own Train • DeJa Vu • Diagnostic System • Dreadnoughts (IIe) • E-Z LOGO • Elementary - Volume 8 • Elementary - Volume 9 • Elementary - Volume 10 • English Parts of Speech • Estimation • Grade Manager • Graph • Graphing Primer • Growgins' Fractions • Guessing and Thinking • Jigsaw • Keyboarding Master • Keyboarding Primer • Kings Quest III • Labels, Letters, and Lists • LOGO Words and Ideas • Management System • Market Place • Master of the Lamps • Math Wizard • Mathematics Volume 1 • Mathematics Volume 2 • Mathematics Volume 3 • Mathematics Volume 4 • Mavis Beacon Teaches Typing v1.5 • Maxi Golf • MECC Speller • Millionaire v2.1 • Mind Puzzles • Mini-putt • Monte Carlo • Number Systems • Nutrition Volume 1 • Nutrition Volume 2 • Oh, Deer! • Paperboy II • Pirates! GS • Prime Numbers • Probability • Problem Solving Strategies • Puzzles and Posters • Rampage • Run Your Own Train • Scoop Mahoney • Shadowgate GS • Shanghai • Showoff v1.1 • Slide Shop • Strip Poker GS • Strip Poker II • Study Guide • Stuff and Fetch • Superprint • Take 1 Deluxe • Tetris • Weather Forecaster • Word Choice 2.0 • Word Match 2.0 • Word Search 3.0 • Word Scramble 3.0 • World Tour Golf • Writing a Narrative • Zany Golf • APT's • Death Sword • Oils' Well • Run For It • Tower of Myrarglen • Wings of Fury • Wizardry V • Playing Tips • Question II • Notes • Changing high scores • Notes on Alien Mind • In the lore library (Wiz V) • Fixing a bug in Wizardry V? • Patch Appleworks cursor, addendum • Notes on copying Tomahawk • Notes on Tetris IBM Softkeys • MultiLink v2.06 • MultiLink v2.08, 2.08c, 3.00c • Professional BASIC • ThinkTank v1.000, 1.001 • Visicalc

64 ● Features: • Apple DuoDisk Modification • The Bard's Dressing Room III • EOADIS Adapter • Merging Controllers into Super IOB • The Product Monitor • Softkeys • 4th & Inches • Ace Reporter • Alphabet Express v2.1.5 • Balance of Power • Bard's Tale II GS • California Games • Crossbow • Crossword Magic 4.0 • Dataquest: Presidents Data Base • Dinosaurs • Dive Bomber • Elementary Social Studies Vol 3 • Elementary Social Studies Vol 6 • Facemaker • Flight Simulator II v2.0 • Galaxian • The Games - Summer Edition • Grammar Gremlins • Kings Quest III • The Last Ninja • Math Shop • Microtype • Mini-Putt • New Oregon Trail • Notes "N" Files • Number Bowling • Paperboy • Path Tactics • PFS Write • Principles of Economics • Reader Rabbit • Shadowgate • Shape Starship v2.1.5 1986 • Skate or Die • Starglider • Star Maze • Story Writer • Super Sign Maker • Troll's Shop Right • Moebius • Wings of Fury • Playing Tips • Alien Mind • Bard's Tale II • The Last Ninja • Notes • A bit copy for Algeblaster • A bit copy for Alien Mind • A bit copy for Homeworker • A bit copy for Where in the USA is Carmen San Diego? • A look at Alien Mind (IIGS) • A look at GS/OS • A look at Tomahawk (IIGS) • An alternate to COPYA? • More on Appleworks and printer codes • Playing Notes on Thexder • Super Index • Bugs? • The meaning of "M" • Saving Strip Poker II pictures • IBM Softkeys • Balance of Power • Enable v1.10 • Mean 18 Golf & Arch • Memory Shift v2.1 • PC Draw v1.4 • Personal Communications Manager v1.0 • Trivia Fever

For a complete back issue list, send a 9" by 12", self-addressed, stamped (25¢) envelope to Computist.

| Issue | Mag | Disk | Both | Issue | Mag | Disk | Both | Issue  | Mag | Disk | Both |
|-------|-----|------|------|-------|-----|------|------|--------|-----|------|------|
| 70    | □   | □    | □    | 45    | □   | □    | □    | 20     | □   | □    | □    |
| 69    | □   | □    | □    | 44    | □   | □    | □    | 19*    | □   | □    | □    |
| 68    | □   | □    | □    | 43    | □   | □    | □    | 18     | □   | □    | □    |
| 67    | □   | □    | □    | 42    | □   | □    | □    | 17     | □   | □    | □    |
| 66*   | □   | □    | □    | 41    | □   | □    | □    | 16*    | □   | □    | □    |
| 65    | □   | □    | □    | 40    | □   | □    | □    | 15     | □   | □    | □    |
| 64    | □   | □    | □    | 39    | □   | □    | □    | 14     | □   | □    | □    |
| 63    | □   | □    | □    | 38    | □   | □    | □    | 13     | □   | □    | □    |
| 62    | □   | □    | □    | 37    | □   | □    | □    | 12     | □   | □    | □    |
| 61    | □   | □    | □    | 36    | □   | □    | □    | 11     | □   | □    | □    |
| 60    | □   | □    | □    | 35    | □   | □    | □    | 10     | □   | □    | □    |
| 59    | □   | □    | □    | 34    | □   | □    | □    | 9      | □   | □    | □    |
| 58    | □   | □    | □    | 33    | □   | □    | □    | 8      | □   | □    | □    |
| 57    | □   | □    | □    | 32    | □   | □    | □    | 7      | □   | □    | □    |
| 56    | □   | □    | □    | 31    | □   | □    | □    | Core 3 | □   | □    | □    |
| 55    | □   | □    | □    | 30    | □   | □    | □    | 6      | □   | □    | □    |
| 54    | □   | □    | □    | 29    | □   | □    | □    | 5      | □   | □    | □    |
| 53    | □   | □    | □    | 28*   | □   | □    | □    | 4      | □   | □    | □    |
| 52    | □   | □    | □    | 27    | □   | □    | □    | 3      | □   | □    | □    |
| 51    | □   | □    | □    | 26    | □   | □    | □    | Core 2 | □   | □    | □    |
| 50    | □   | □    | □    | 25    | □   | □    | □    | 2      | □   | □    | □    |
| 49    | □   | □    | □    | 24    | □   | □    | □    | 1      | □   | □    | □    |
| 48    | □   | □    | □    | 23    | □   | □    | □    | Core 1 | □   | □    | □    |
| 47    | □   | □    | □    | 22    | □   | □    | □    |        |     |      |      |
| 46    | □   | □    | □    | 21    | □   | □    | □    |        |     |      |      |

Best of Hardcore Computing ..... ● □ ●  
(Only the disk is available)

Some disks apply to more than one issue and are shown as taller boxes. Special "Both" disk & magazine combination orders apply to one issue and its corresponding disk.

☆ Limited supply; first-come-first-serve basis.

● Not available.

○ Out-of-print; only "Zeroxed" copies for sale.

\* Issue 66 is laser printed on 8 1/2" by 11 paper.

## Back Issue Order Form

**COMPUTIST back issues and library disks are frequently referenced in current issues.**

### Back Issue and Library Disk Rates

|                     | US, Canada & Mexico | All others |
|---------------------|---------------------|------------|
| Back issues (1 - 9) | \$4.75              | \$8.75     |
| Back issues (10+)   | \$3.75              | \$6.00     |
| Zox back issues     | \$4.75              | \$8.75     |
| Library disks       | \$5.50              | \$7.50     |
| Issue + Disk        | \$8.00              | \$11.50    |
| Zox issue + Disk    | \$10.25             | \$14.25    |

Due to the time and effort involved in making Zox copies, their price will remain at \$4.75 each for US, Canada & Mexico and at \$8.75 for all other Foreign.

Shipping is included in all the prices shown.

## What's a library disk?

A library disk is a 5 1/4 inch floppy diskette that contains programs that would normally have to be typed in by the user. Documentation for each library disk can be found in the corresponding issue.

Library disks are available for all issues of COMPUTIST.

Number of back issues. \$ \_\_\_\_\_  
Number of Zox back issues. \$ \_\_\_\_\_  
Number of library Disks. \$ \_\_\_\_\_  
Number of back issues + Disk. \$ \_\_\_\_\_  
Number of Zox back issues + Disk. \$ \_\_\_\_\_  
Tax (7.8%) for Washington Residents. \$ \_\_\_\_\_

Name \_\_\_\_\_ ID# \_\_\_\_\_  
Address \_\_\_\_\_  
City \_\_\_\_\_ State \_\_\_\_\_ Zip \_\_\_\_\_  
Country \_\_\_\_\_ Phone \_\_\_\_\_  
 Visa       MC      Exp. \_\_\_\_\_

Signature \_\_\_\_\_ CP71  
• US funds drawn on US bank. • Most orders shipped within 5 working days, however please allow up to 4 weeks delivery for some orders. • Orders shipped UPS so you must use street address. • Offer good while supply lasts. • Send check/money order to:

COMPUTIST 33821 E Orville Road Eatonville WA 98328 (206) 474-5750